

75835

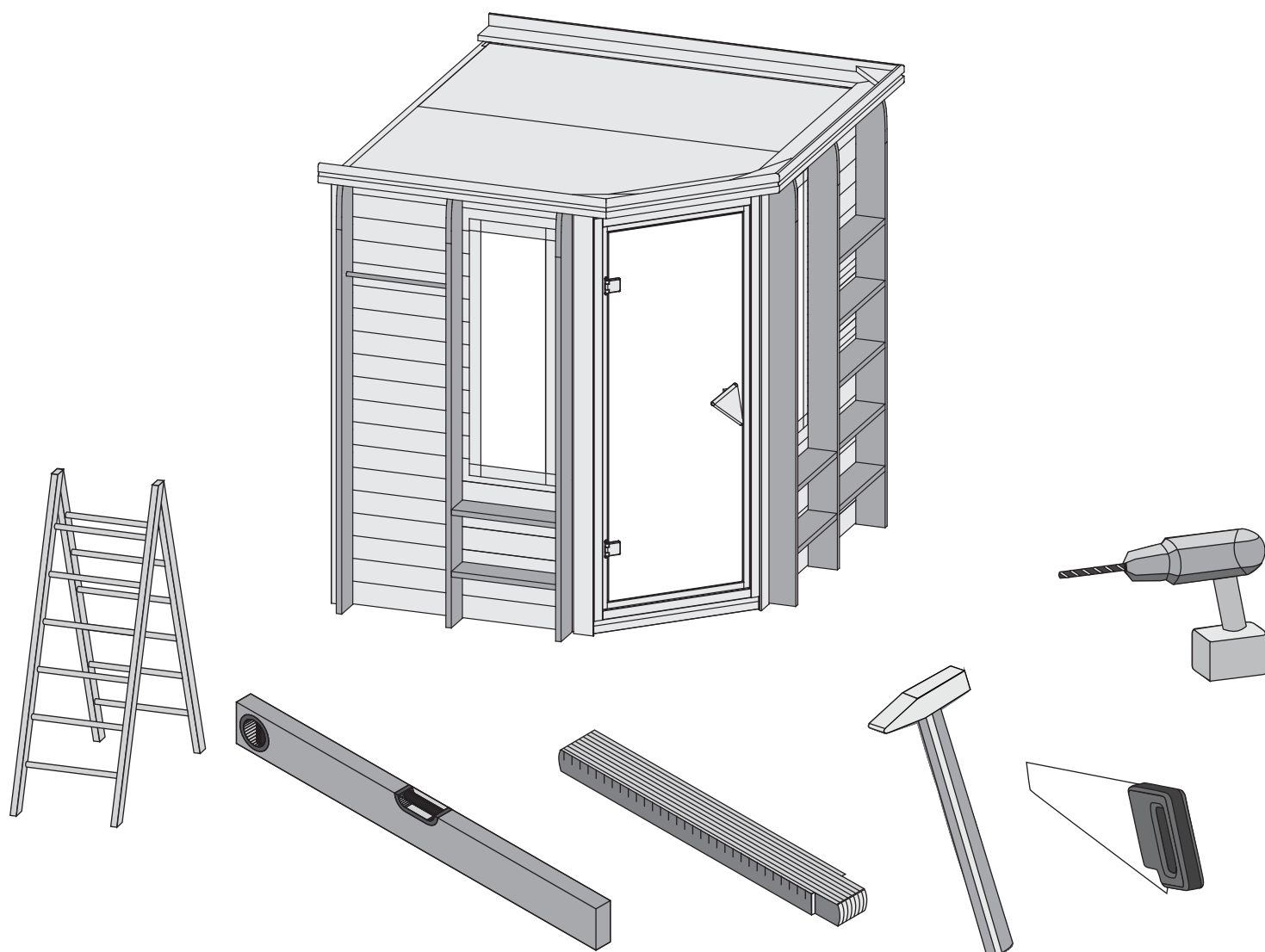

 **Aufbauanleitung**

 **notice de montage**

 **Building Instructions**

 **montagehandleiding**

 **Instrucciones de construcción**

 **Istruzioni per il montaggio**

 **Montážní návod**

 **Service-Hotline: +49 421 38693 33**



Vergleichen Sie zuerst die Material-liste mit Ihrem Paketinhalt! Bitte haben Sie Verständnis, dass Beanstandungen nur im nicht aufgebauten Zustand bearbeitet werden können!



En primer lugar, compare la lista de material con el contenido del paquete. Rogamos entienda que las reclamaciones sólo pueden ser tramitadas antes de montar el objeto!



Nejprve překontrolujte obsah balení podle materiálového listu! Mějte pochopení pro to, že případnou reklamaci se můžeme zabývat pouze tehdy, když díly nebudou smontované! Za pomoci tohoto seznamu můžete jednotlivé díly přiřadit k montážnímu návodu.



Vergelijk eerst de lijst van materialen met de inhoud van uw pakket! Reclamaties kunnen alleen in behandeling worden genomen zolang de onderdelen nog niet zijn gemonteerd!



First compare the list of materials with your package contents! Please understand that complaints can be processed in the non-built status only!



Commencez par comparer la liste du matériel avec le contenu de votre paquet! Sachez que nous traitons uniquement les réclamations concernant le matériel à l'état non monté!



Confrontate questa distinta materiali prima con il contenuto del pacchetto! Vi preghiamo di comprendere che eventuali reclami possono essere accolti solo prima del montaggio!

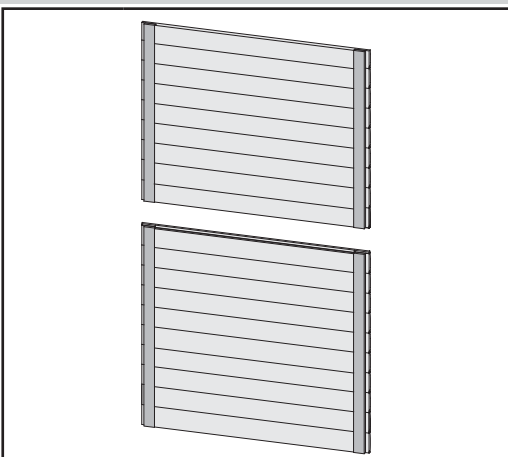
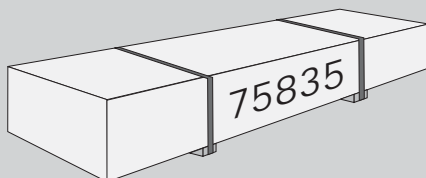

1 x W1	2040 x 1178 x 40 mm	ID 20716
1 x W2	2040 x 1770 x 40 mm	ID 20719

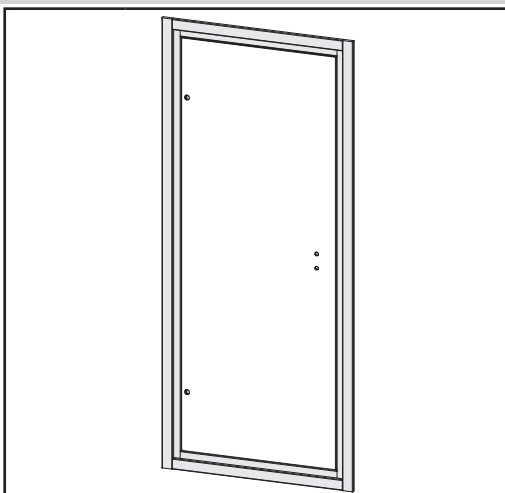

1 x W5	1911 x 815 x 40 mm	ID 20527
--------	--------------------	----------

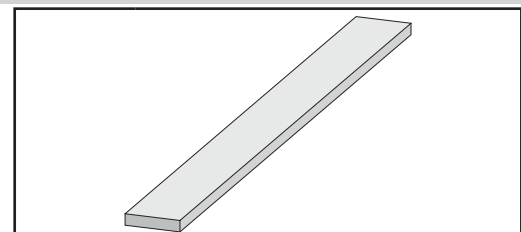

1 x B1	1920 x 19 x 3 mm	ID 20799
1 x B2	300 x 95 x 18 mm	ID 19130
4 x B3	60 x 38 x 28 mm	ID 20928
2 x B4	550 x 38 x 28 mm	ID 22865
2 x B5	1120 x 38 x 28 mm	ID 26146
1 x B6	1731 x 38 x 28 mm	ID 20698
1 x B7	1756 x 38 x 28 mm	ID 20699

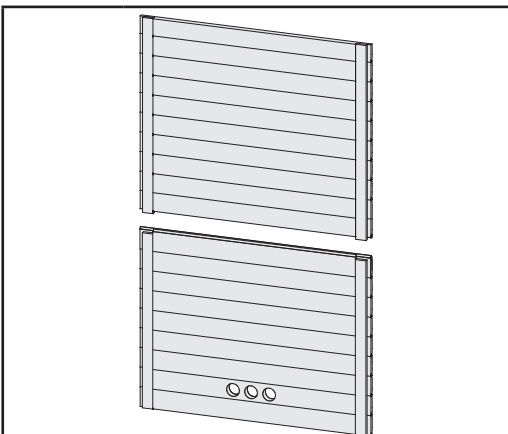

1 x W3	2040 x 1278 x 40 mm	ID 20720
--------	---------------------	----------

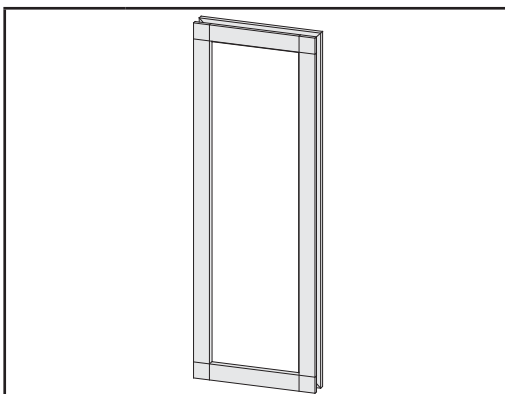

2 x F1	1220 x 420 x 40 mm	ID 68247
--------	--------------------	----------

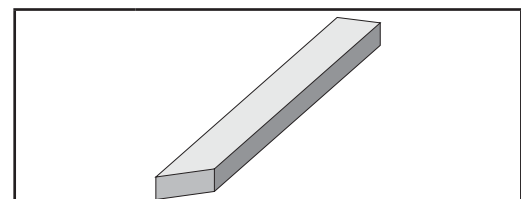

1 x C1	1293 x 140 x 26 mm	ID 26217
1 x C2	1473 x 140 x 26 mm	ID 40000
1 x C3	1952 x 140 x 26 mm	ID 26207
1 x C4	1167 x 38 x 28 mm	ID 20694
1 x C5	1220 x 38 x 28 mm	ID 20695

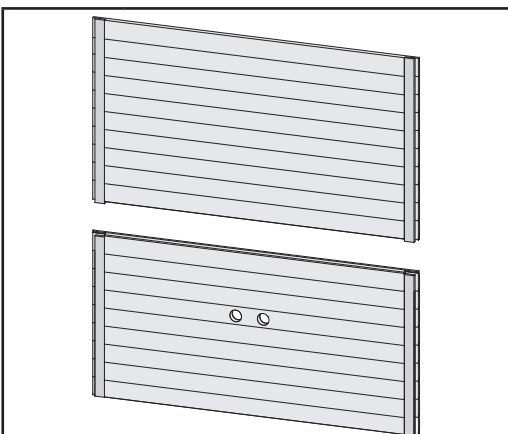

1 x W4	2040 x 1888 x 40 mm	ID 20712
--------	---------------------	----------

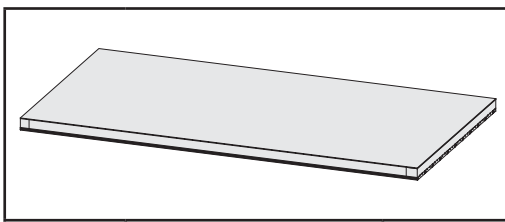

1 x M1	1727 x 904 x 57 mm	ID 43858
--------	--------------------	----------

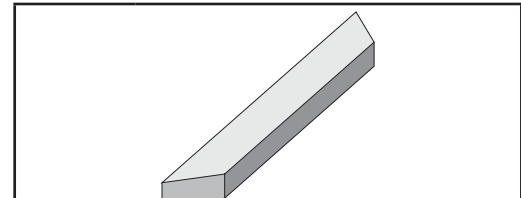

1 x C6	932 x 190 x 26 mm	ID 39156
1 x C7	799 x 38 x 28 mm	ID 20691

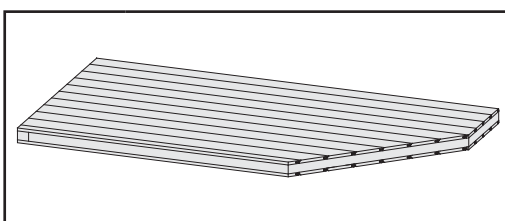

1 x M2	1727 x 904 x 68 mm	ID 56972
--------	--------------------	----------

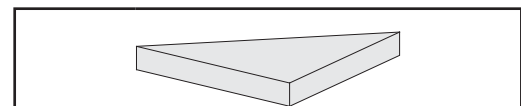

1 x A1	298 x 140 x 26 mm	ID 26210
--------	-------------------	----------



2 x A2	400 x 140 x 26 mm	ID 26209
--------	-------------------	----------

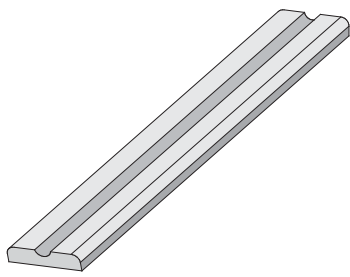

1 x D1	850 x 90 x 22 mm	ID 60859
1 x D2	1375 x 90 x 22 mm	ID 60860
1 x D3	1575 x 90 x 22 mm	ID 60861
1 x D4	1975 x 90 x 22 mm	ID 60856

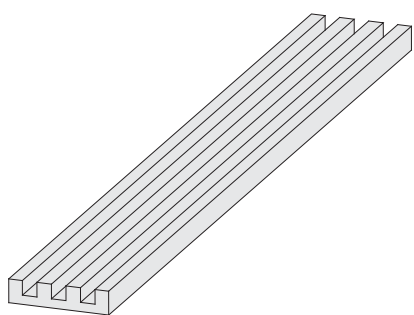
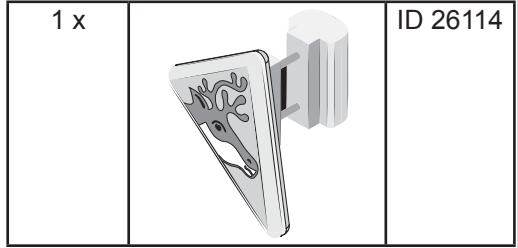
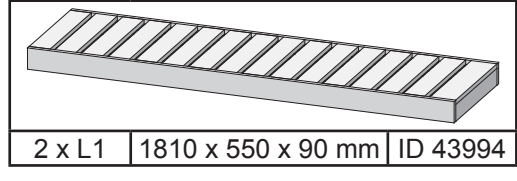
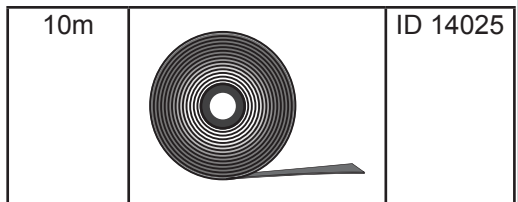
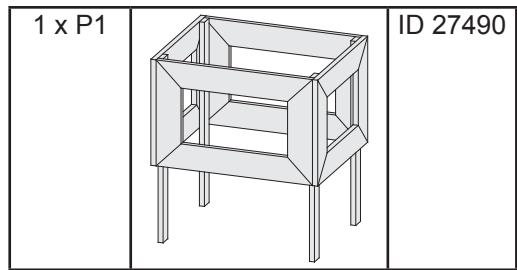

1 x E1 | 1850 x 140 x 26 mm | ID 26480

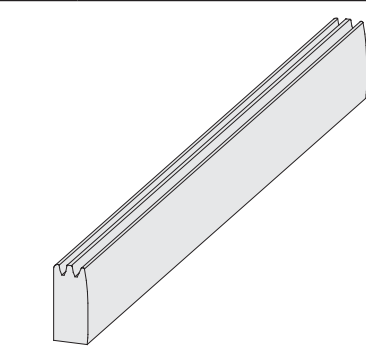
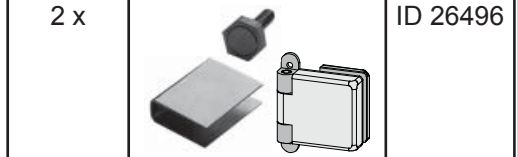
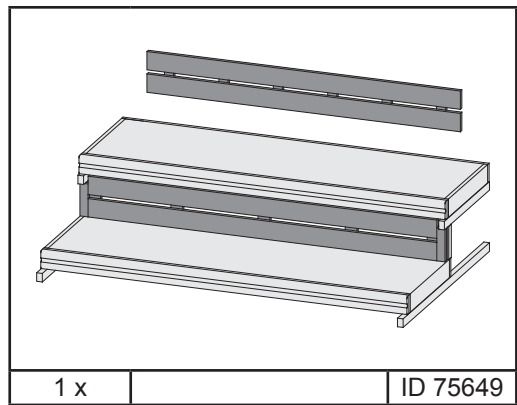

2 x E2 | 815 x 84 x 40 mm | ID 20635

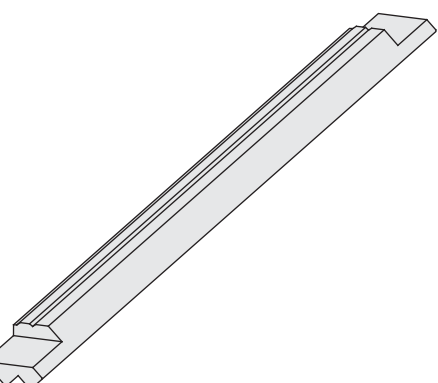
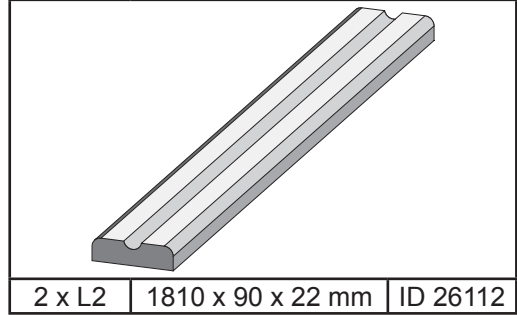

2 x E3 | 2040 x 61 x 38 mm | ID 20701

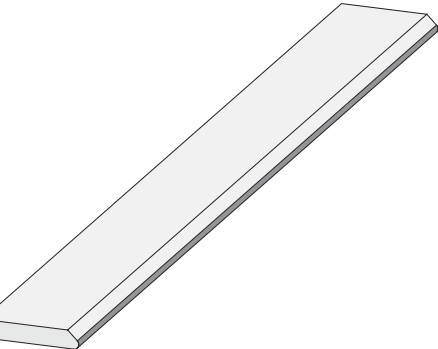
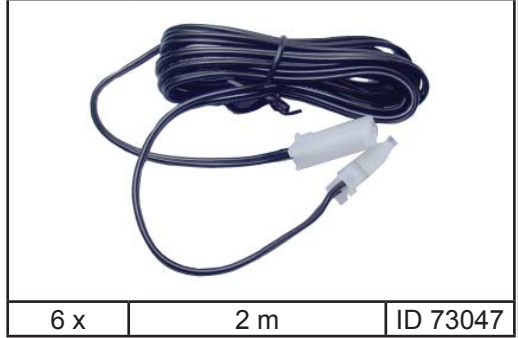
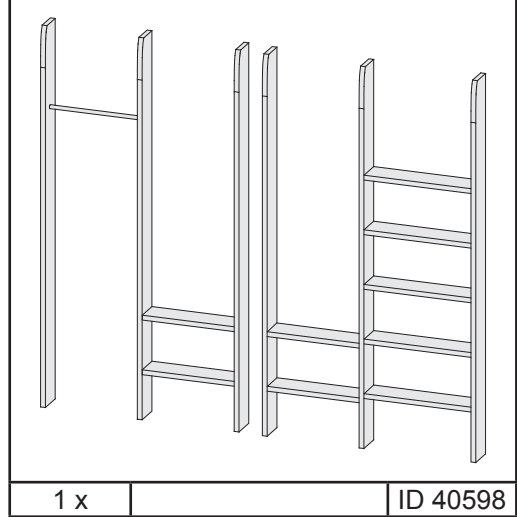

4 x G1 | 2040 x 78 x 17 mm | ID 48523
2 x G2 | 2040 x 95 x 17 mm | ID 48522

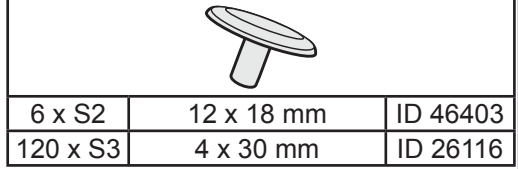
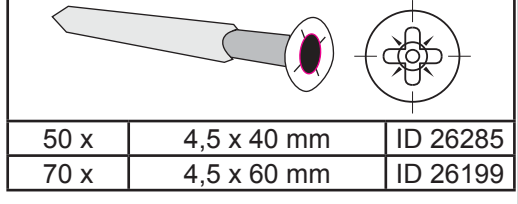
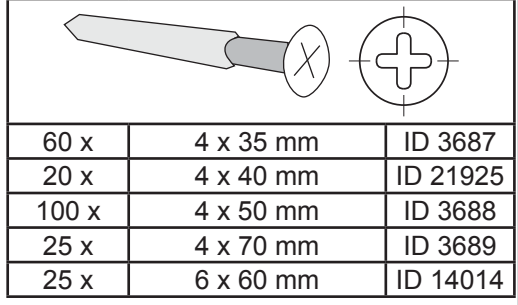
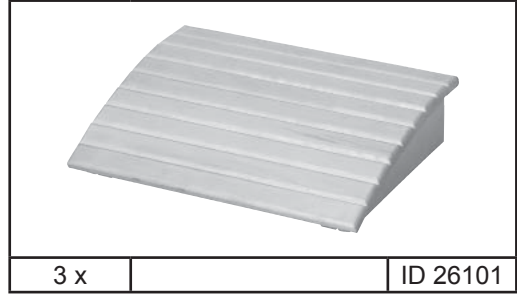

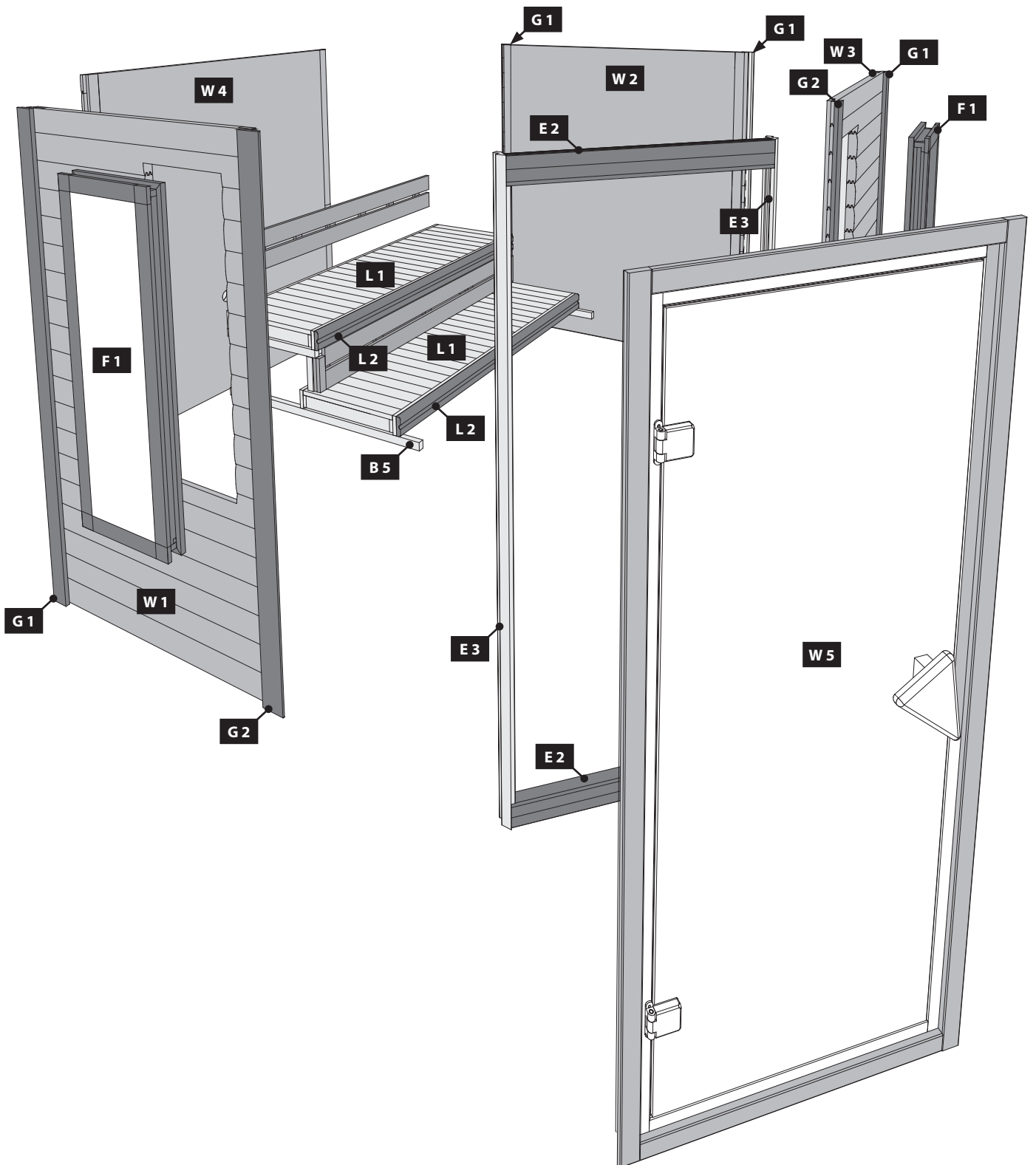
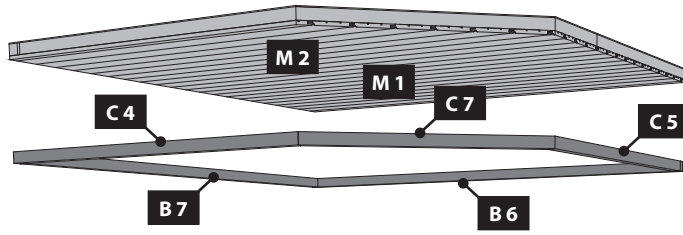
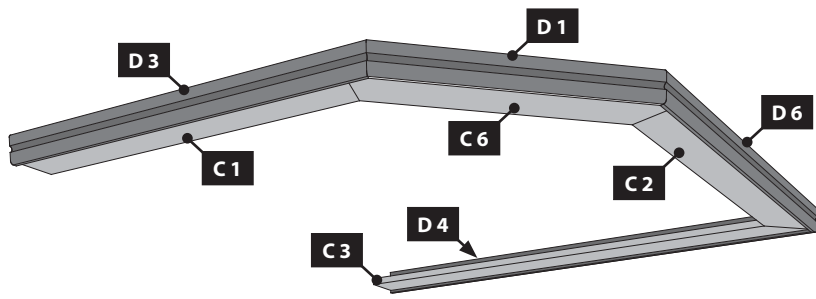

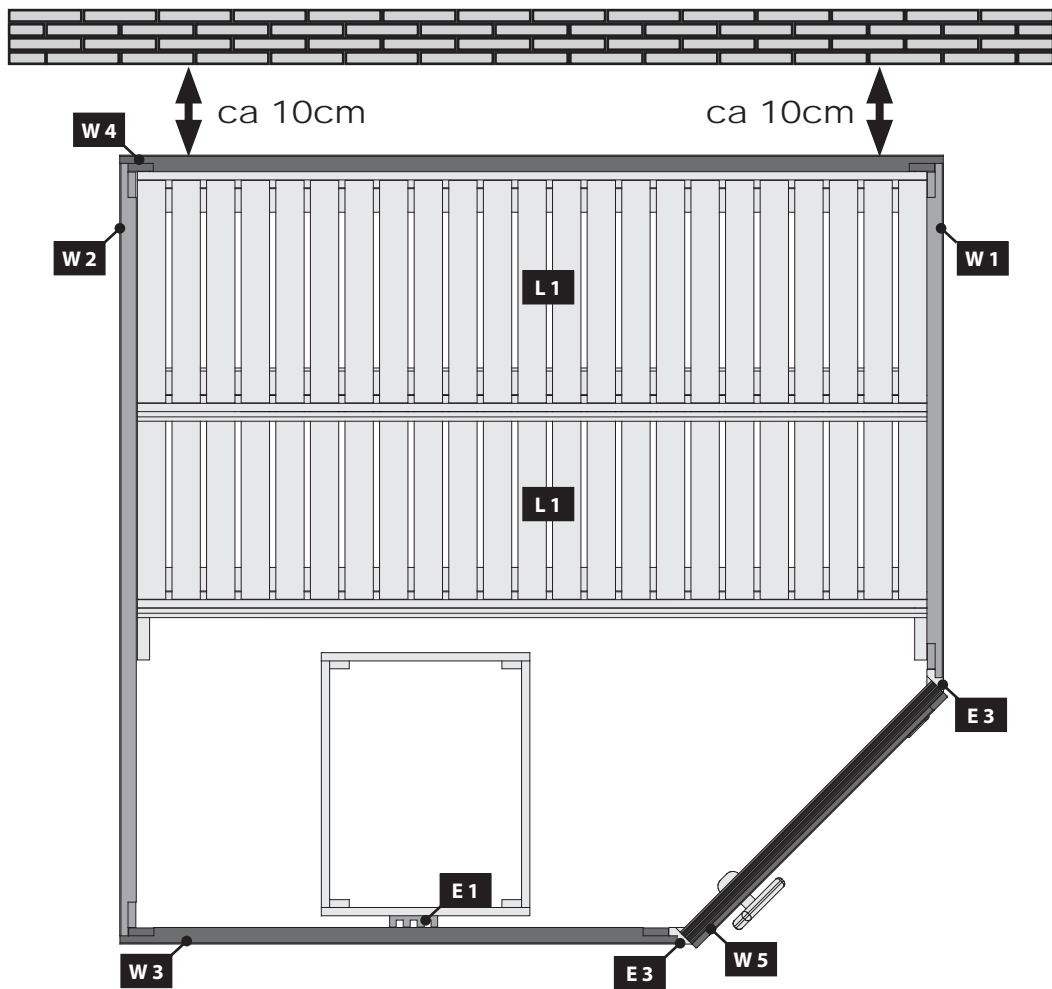
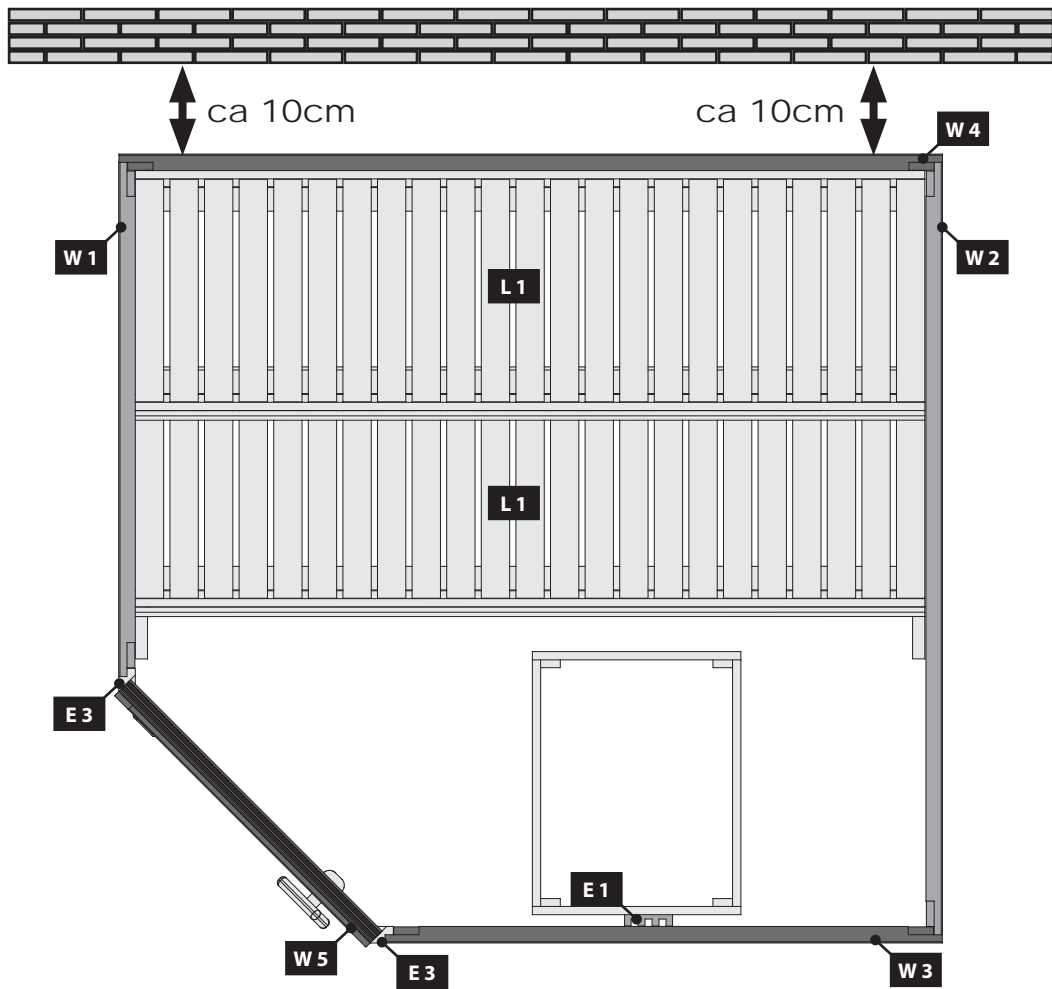

01



Ø3mm 4x50

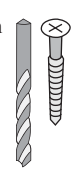

01.1

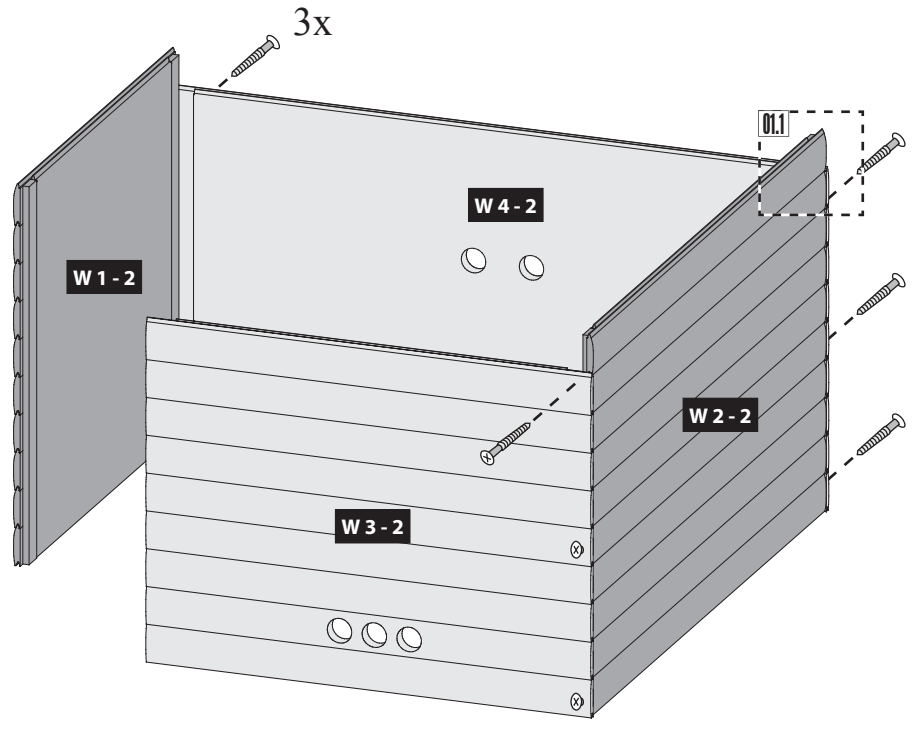
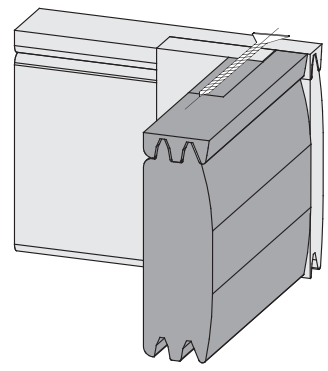

02.1

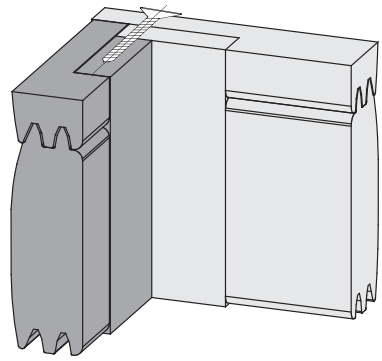

02

Ø3mm 4x50

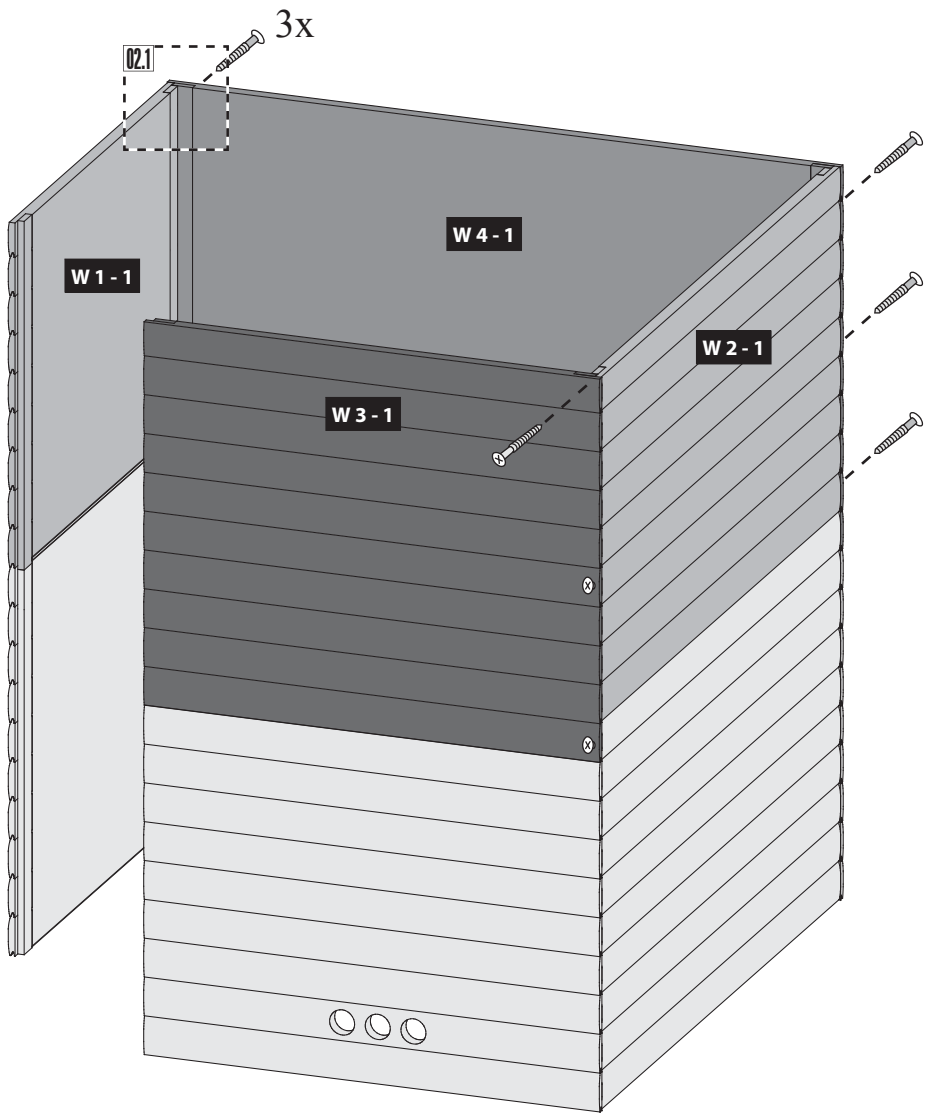
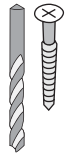

03

Ø3mm 4x70

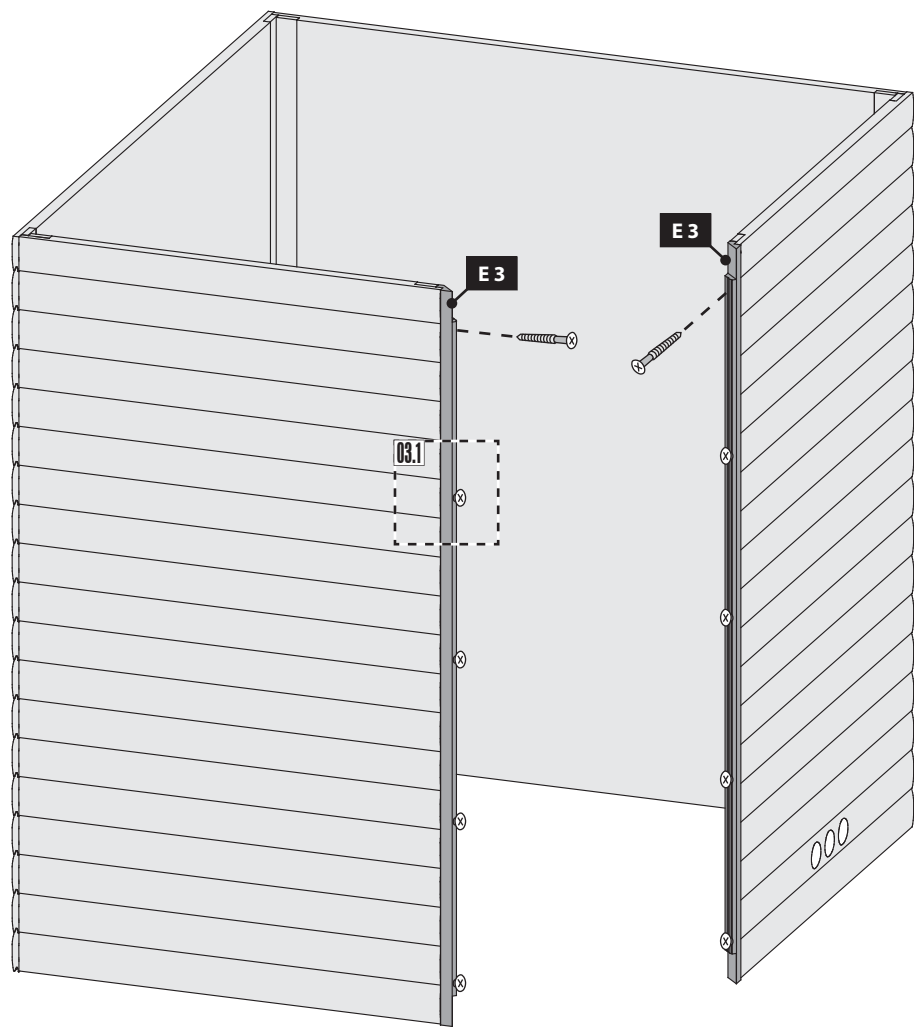
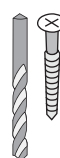

03.1

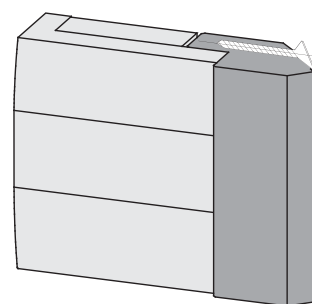

04

Ø3mm 4x35

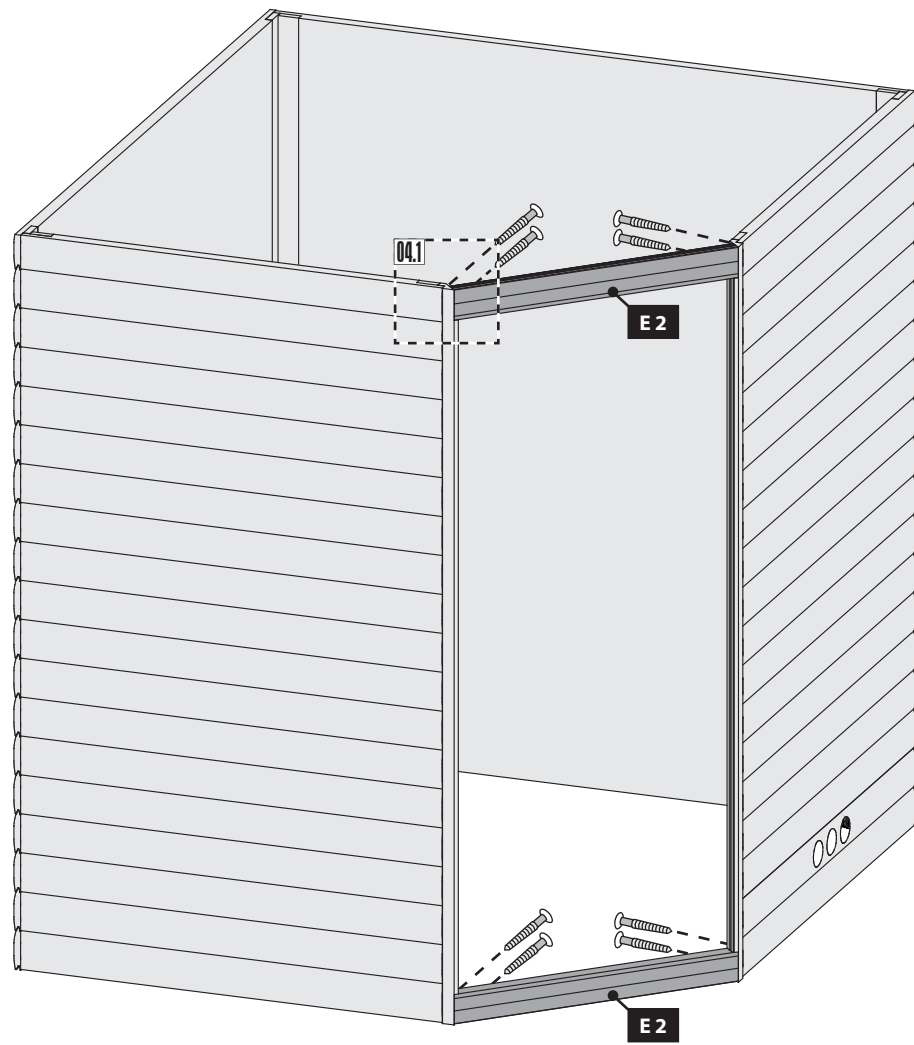
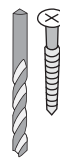

04.1

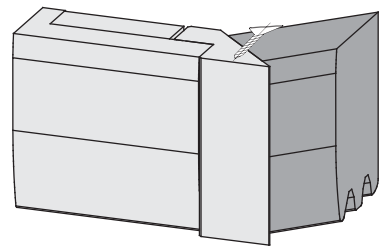



- | | |
|--|---|
|  Einbau Glastür |  Montaje de la puerta de cristal |
|  Montage porte en verre |  Installazione portello di vetro |
|  Installation of glass door |  Namestitev steklena vrata |
|  Montage van de glazen deur | |



05



05.1-1

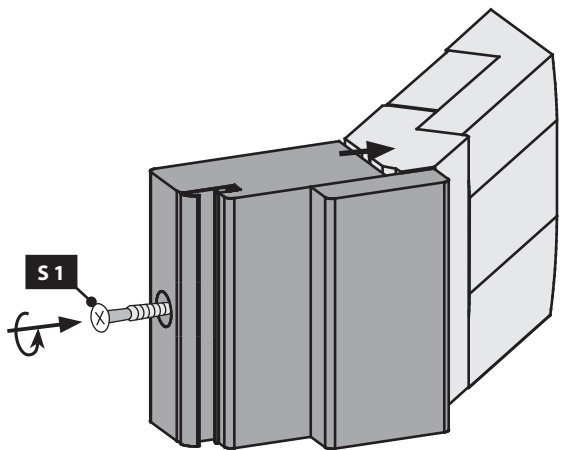

05.1-1

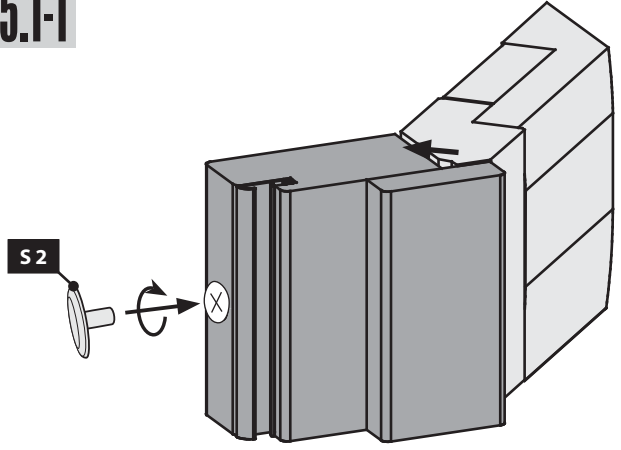

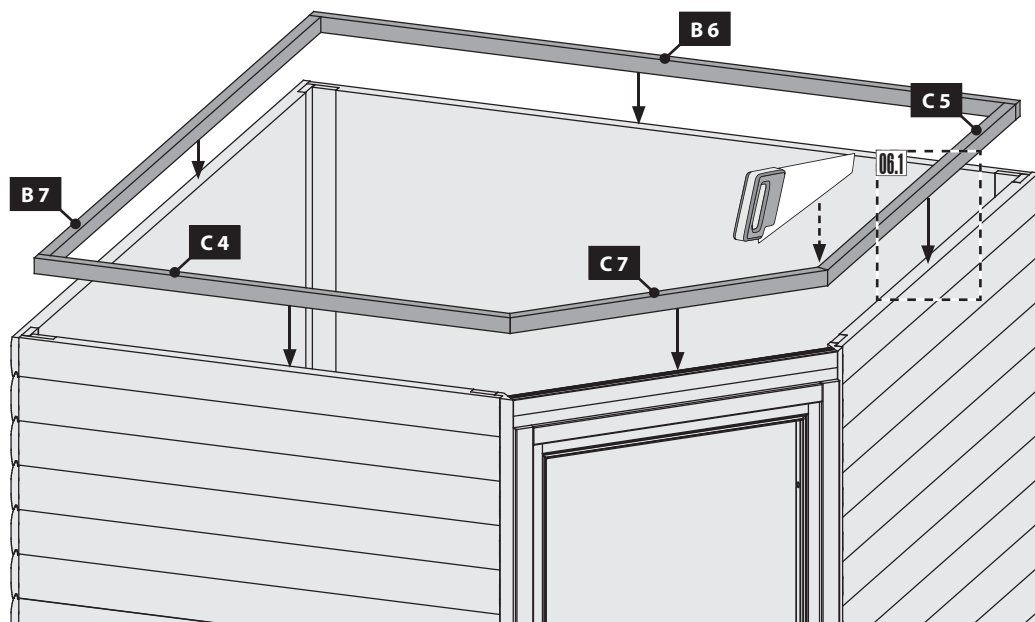
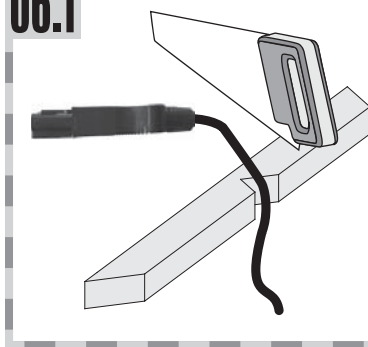
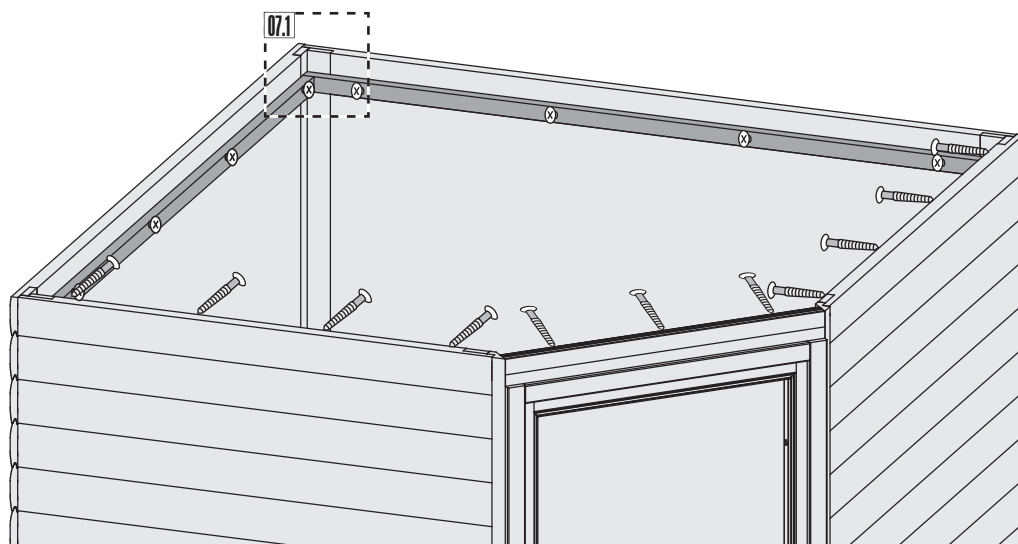
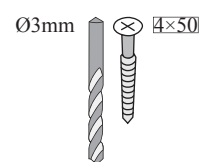
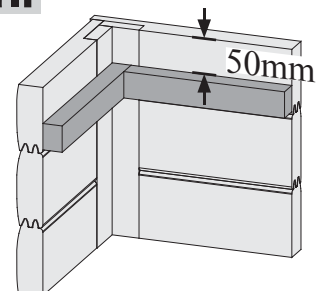
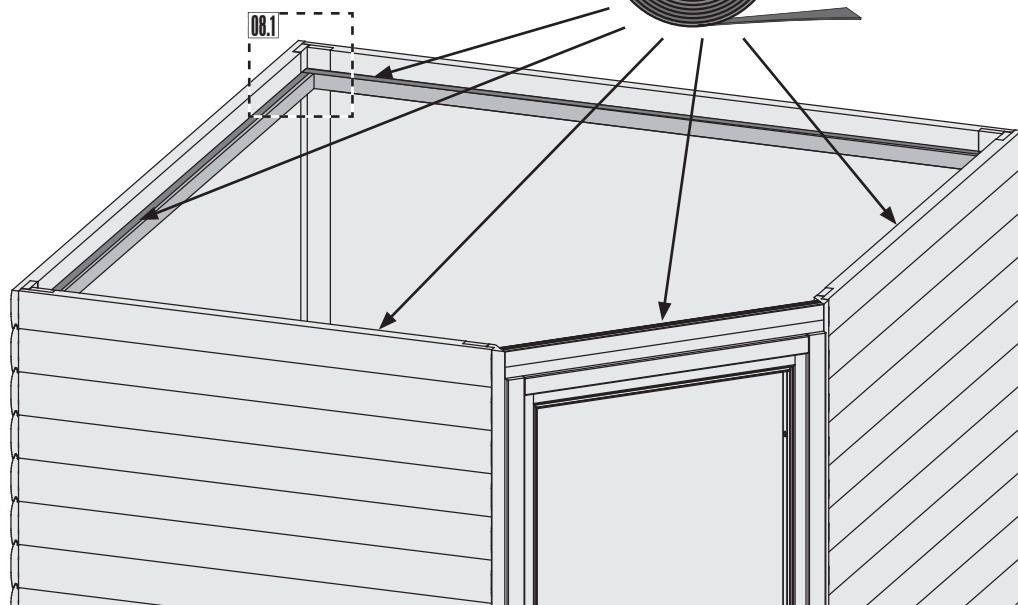
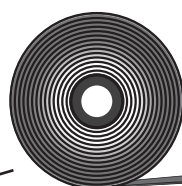
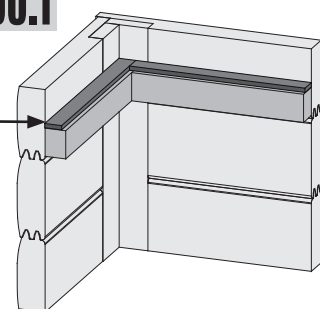
06**06.1****07****07.1****08****08.1**

09

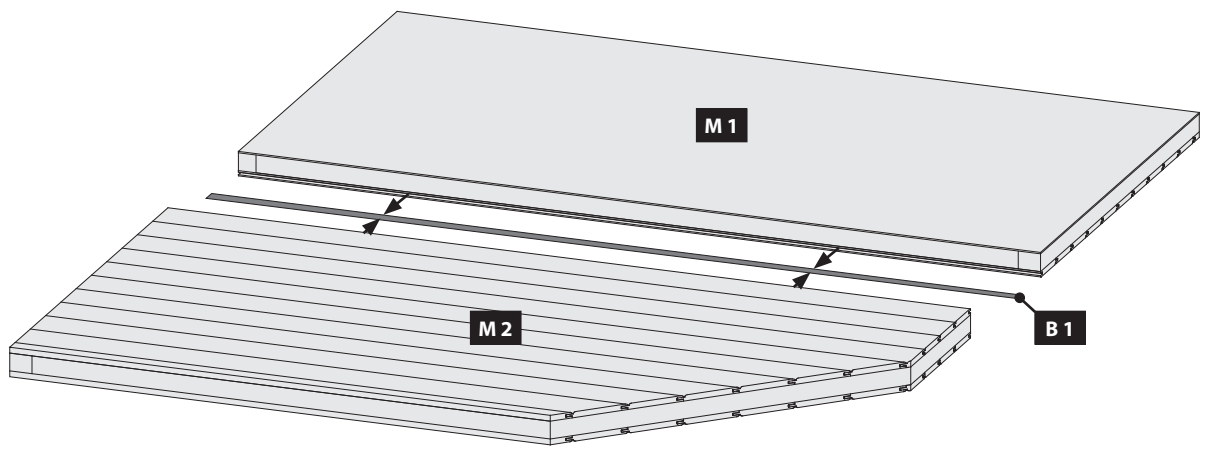

10

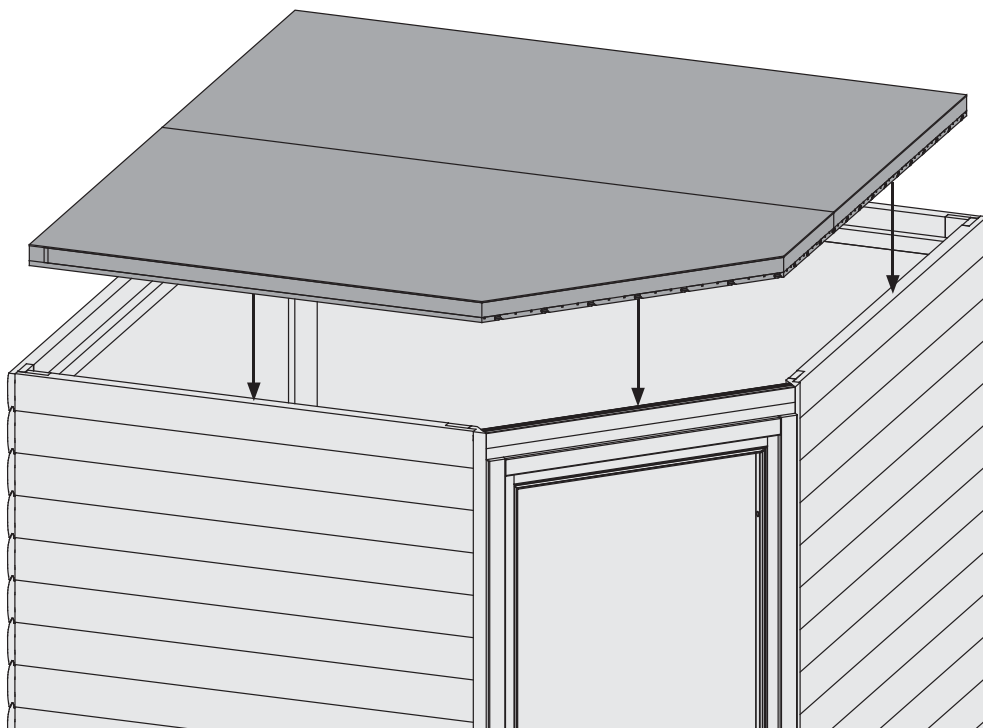

11.1

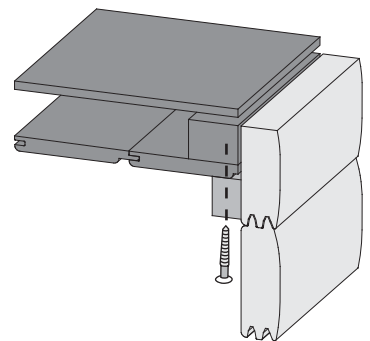

11

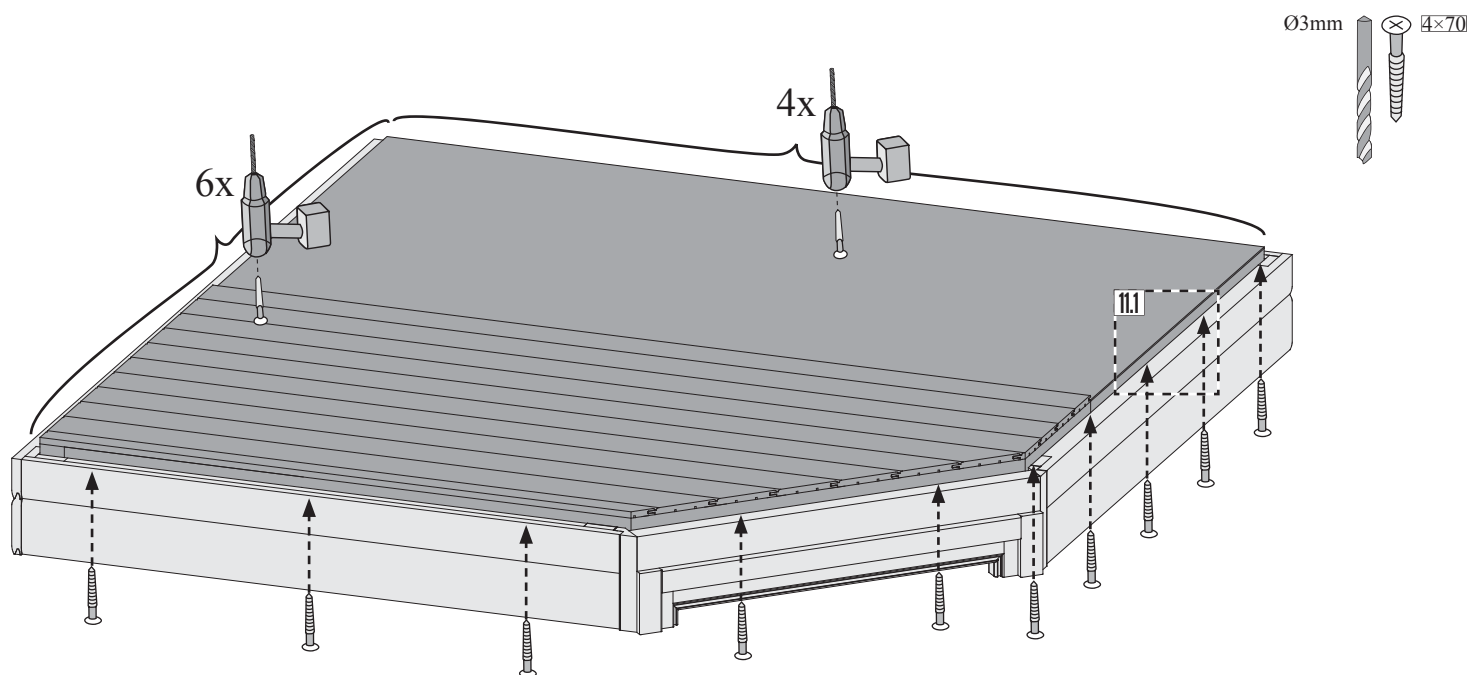

12

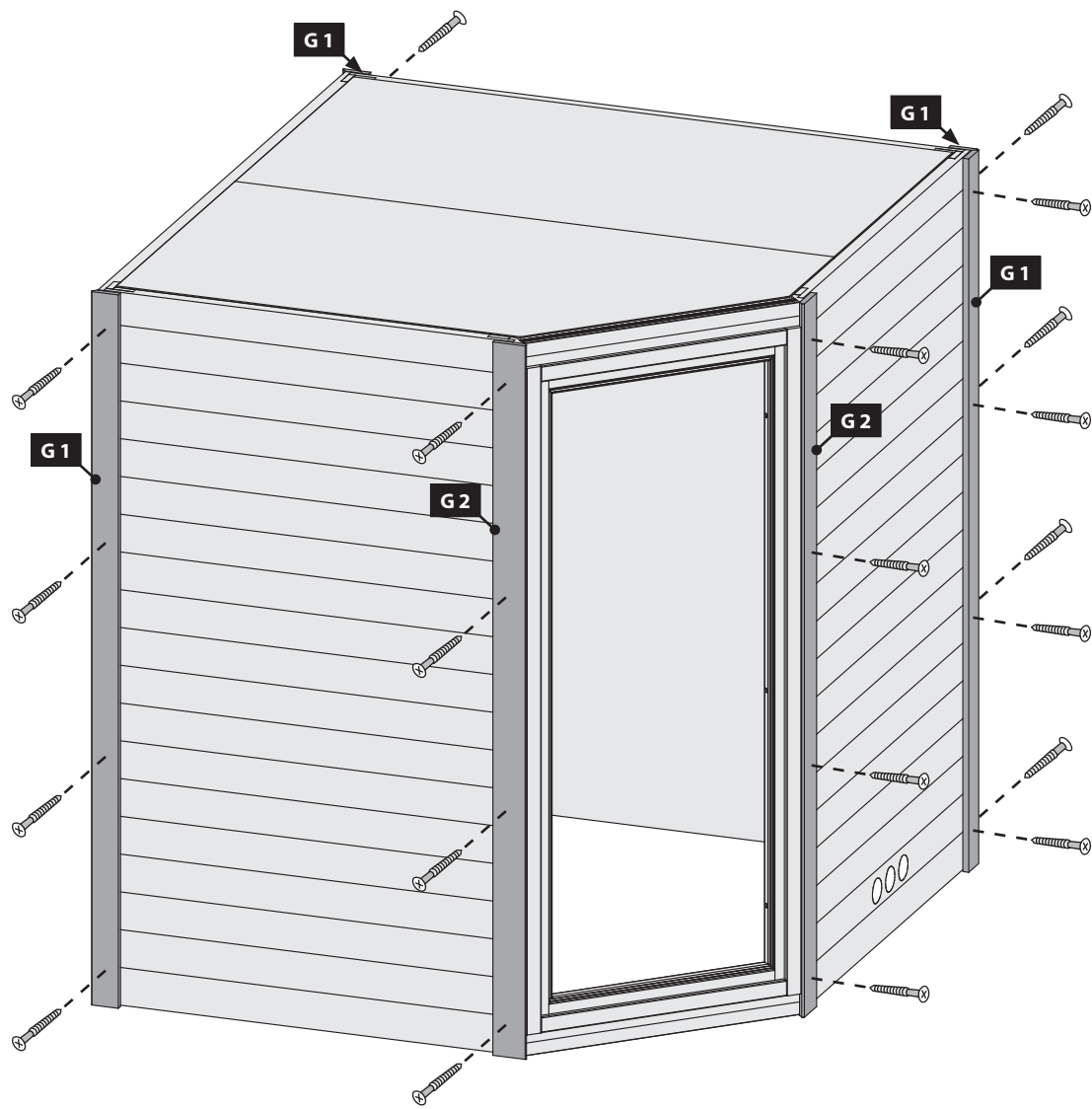

13

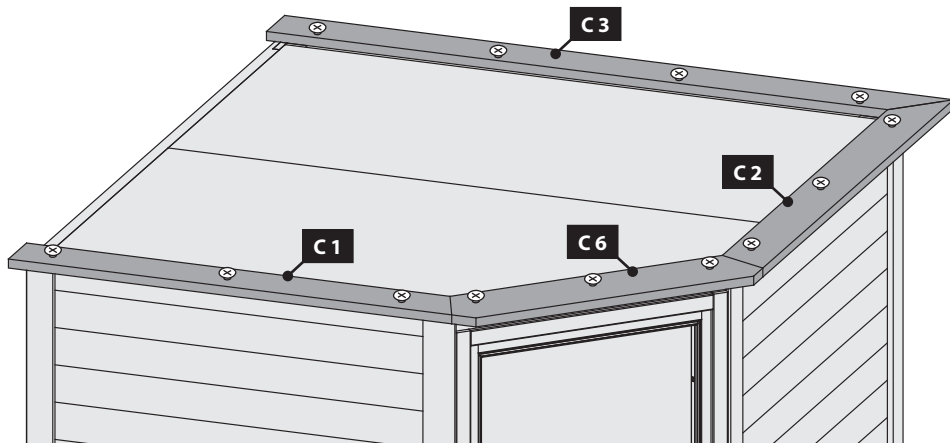

14

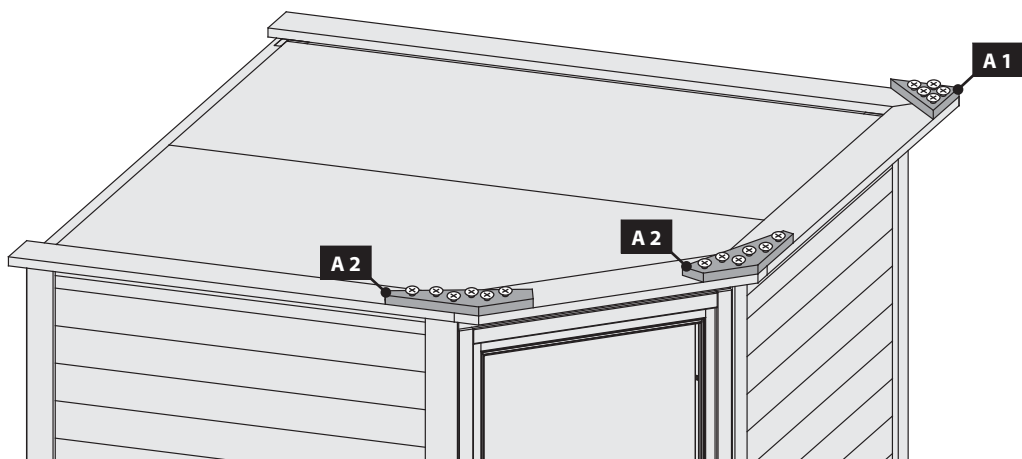

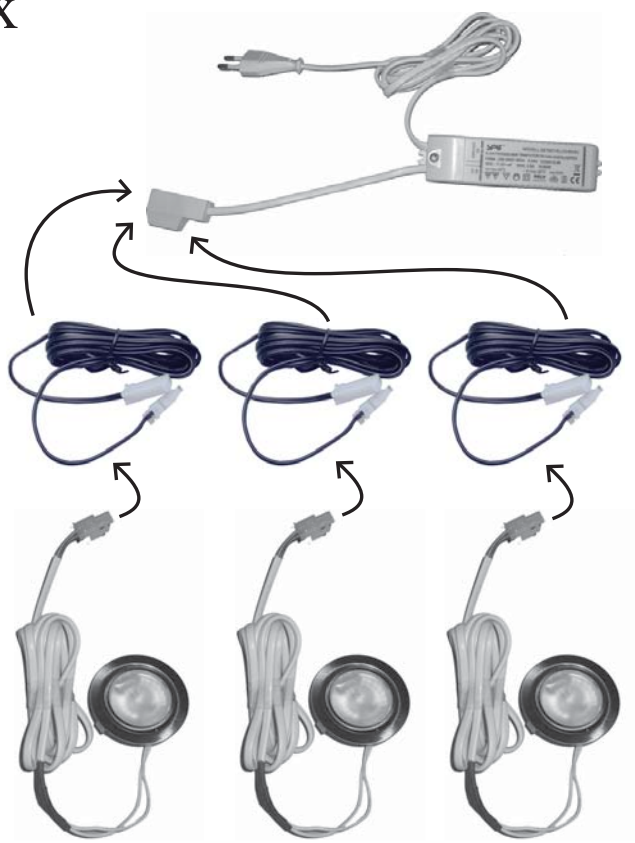
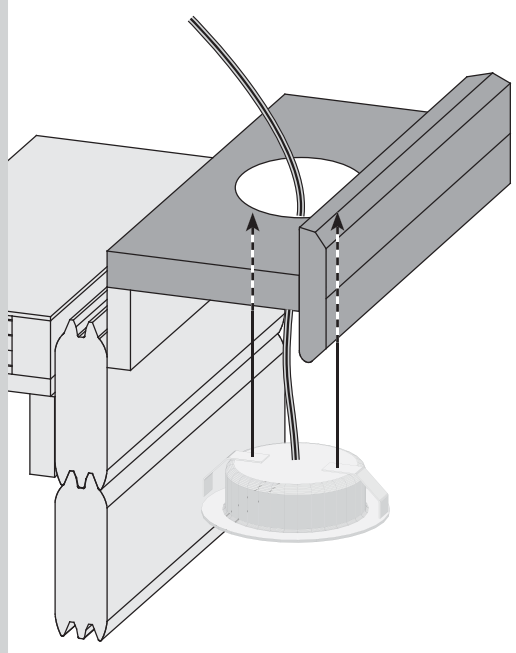
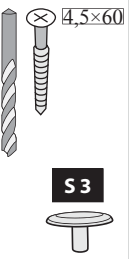

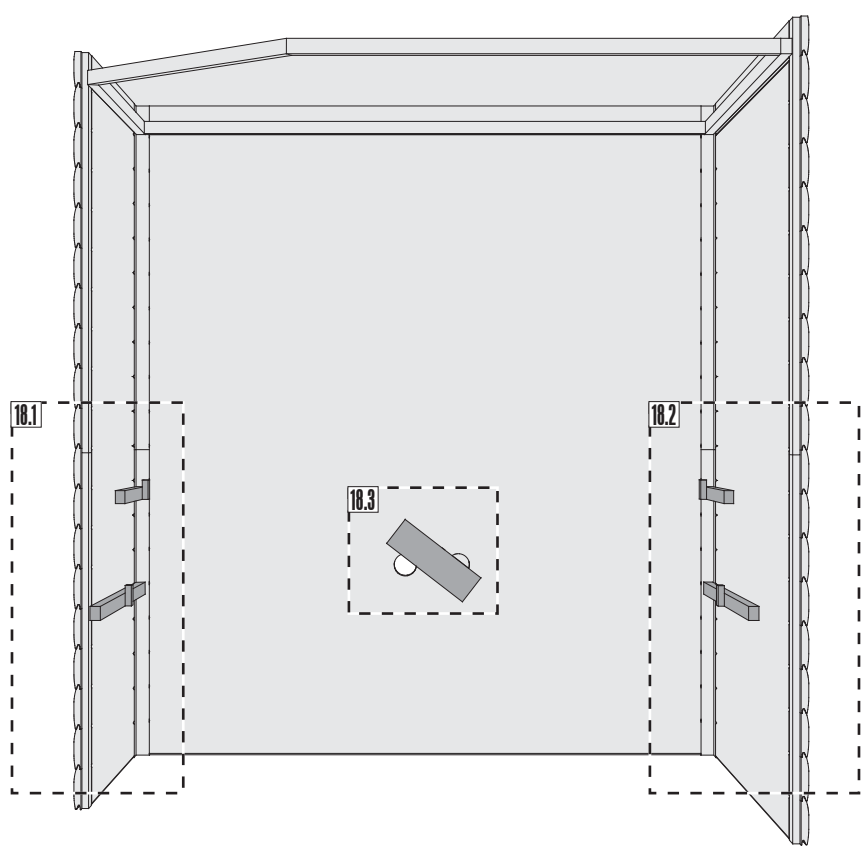



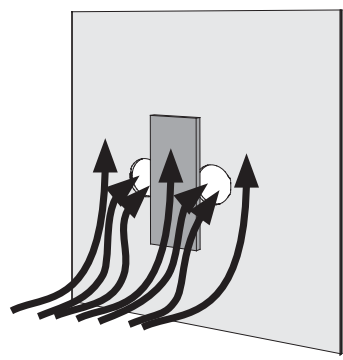
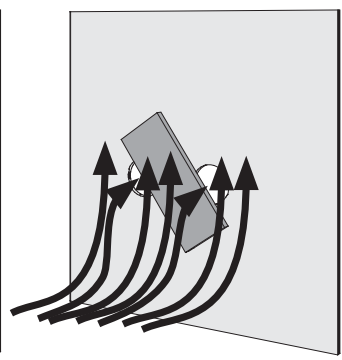
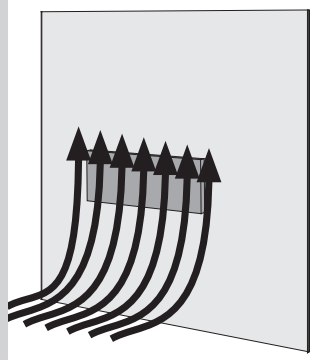
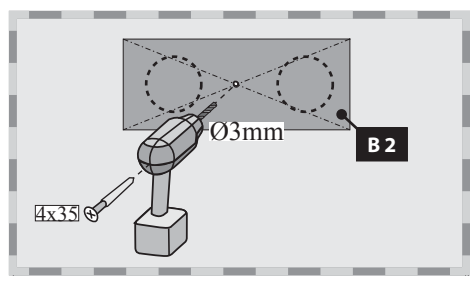

18.3





 Hier ist die Funktionsweise des Brettes abgebildet. Regeln Sie damit die Abluft nach Ihren eigenen Wünschen.

 Ceci représente le mode de fonctionnement de la planche. Avec elle, réglez l'écoulement de l'air selon vos désirs.

 This figure shows the functional principle of the board. Regulate the exhaust air according to your own wishes.

 Hier is de werking van het plankje afgebeeld. Regel daarmee de luchtafvoer naar eigen wens.

 Aquí está representada la forma de funcionamiento de la tabla. Regule con ello el aire de salida según sus propios deseos.

 Viene illustrato il principio di funzionamento della tavoletta di regolazione della ventilazione. Con essa si può regolare a piacere la ventilazione.

 Zde je zobrazená funkce desky. Regulujte s ní odsávací vzduch dle Vašeho přání.

18.1-1

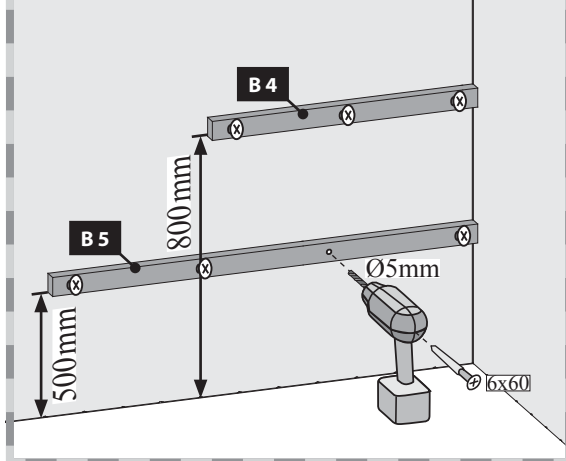

18.1-2

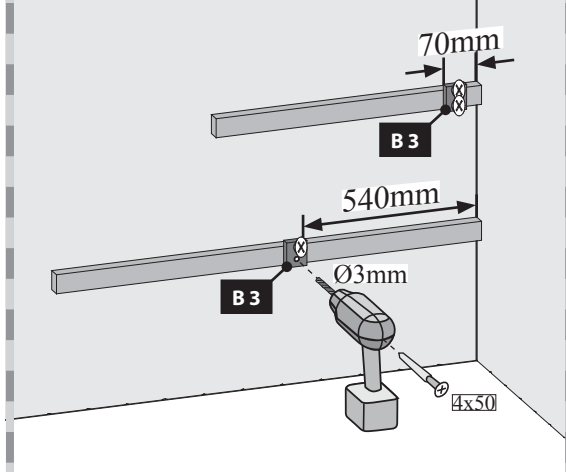

18.2-1

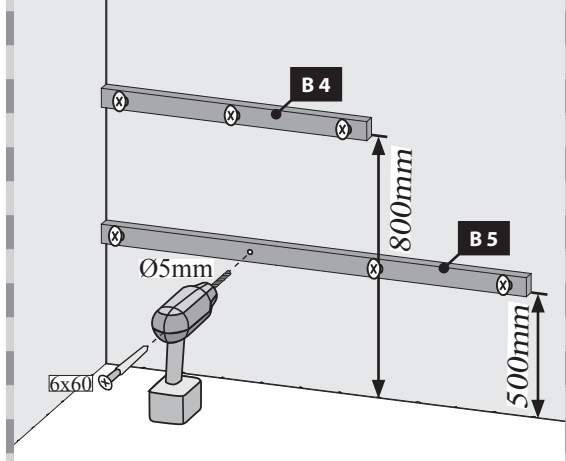

18.2-2

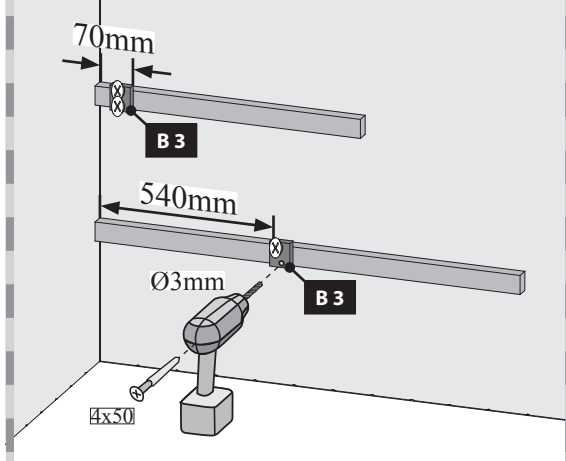

19 2x

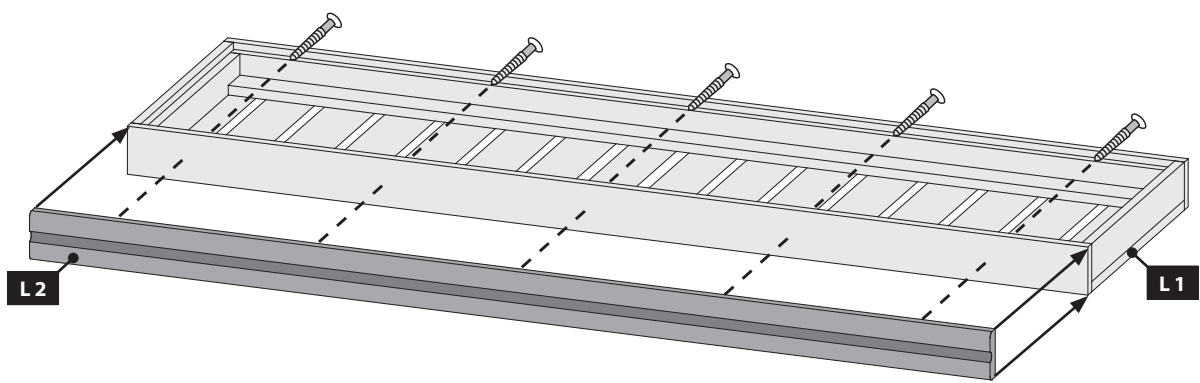
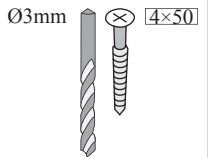
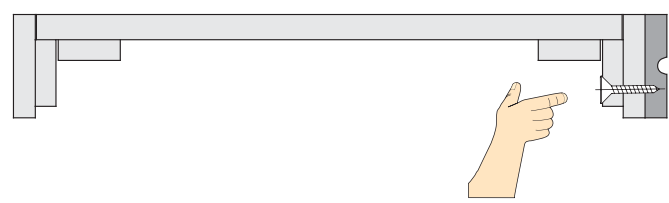
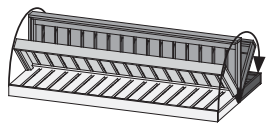

20

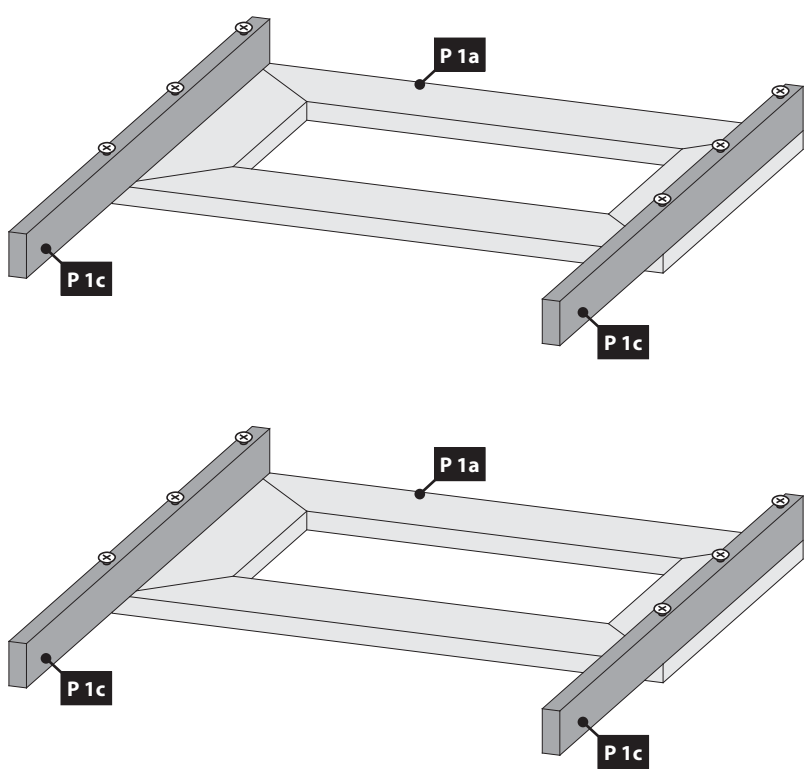
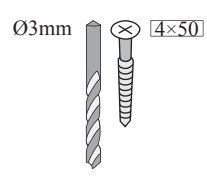

21

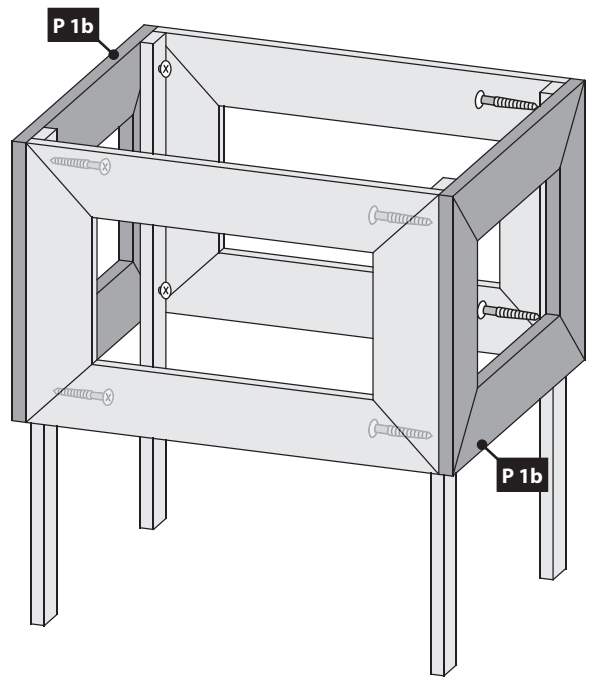
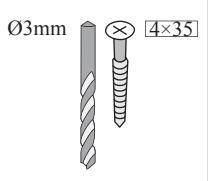

22

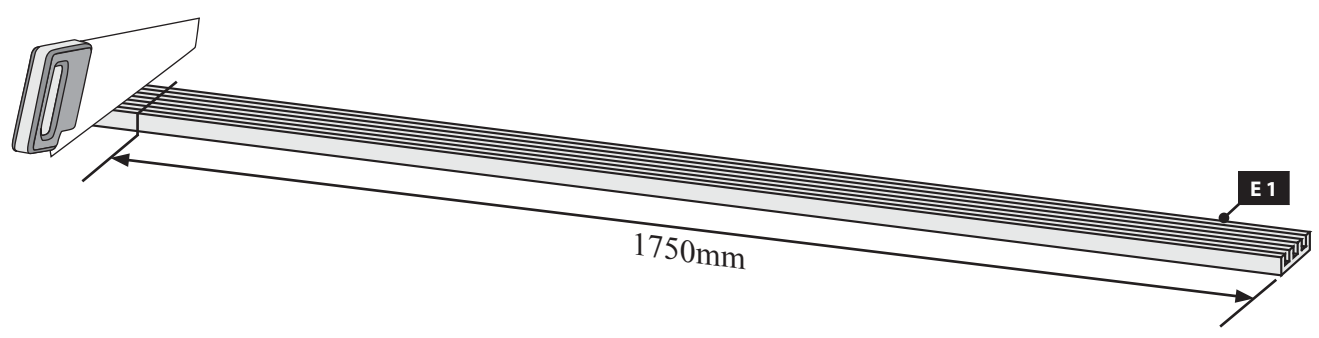

23

Ø3mm 4x50

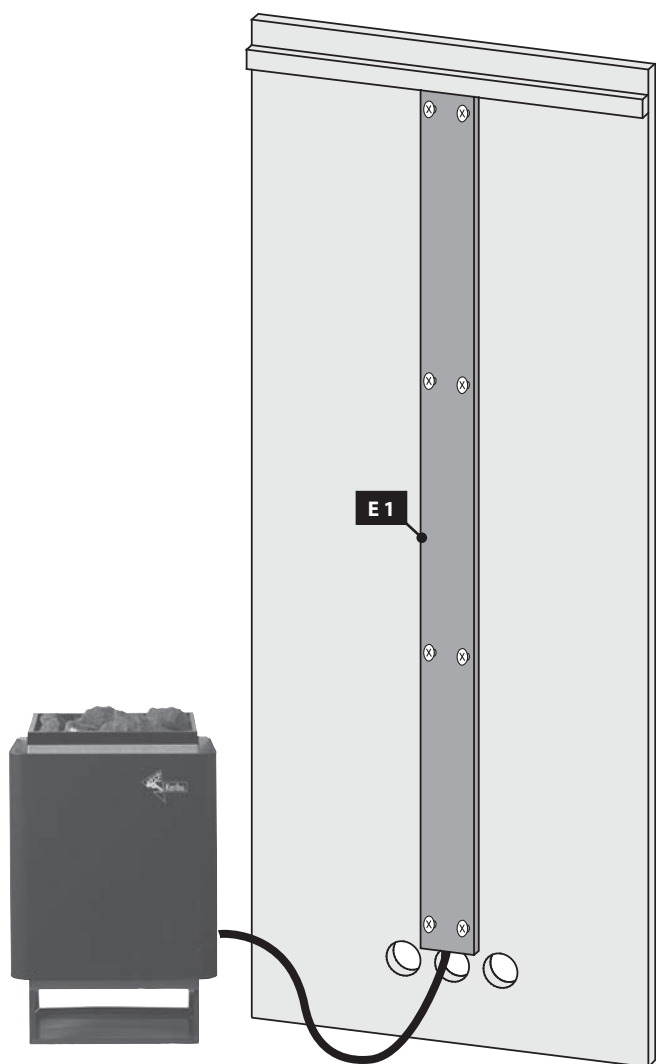
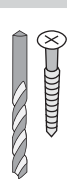

24





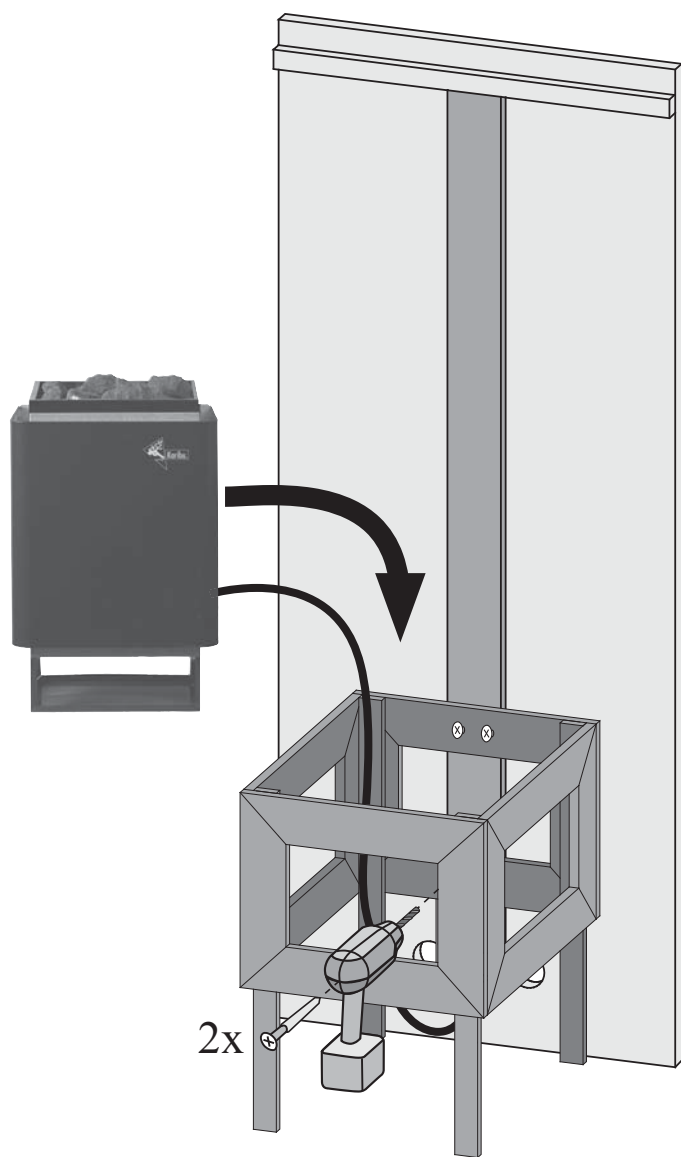
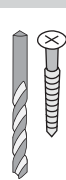



Ø3mm 4x70



04 — 08



-  Einbau Glastür
-  Montage porte en verre
-  Installation of glass door
-  Montage van de glazen deur

-  Montaje de la puerta de cristal
-  Installazione portello di vetro
-  Namestitev steklena vrata



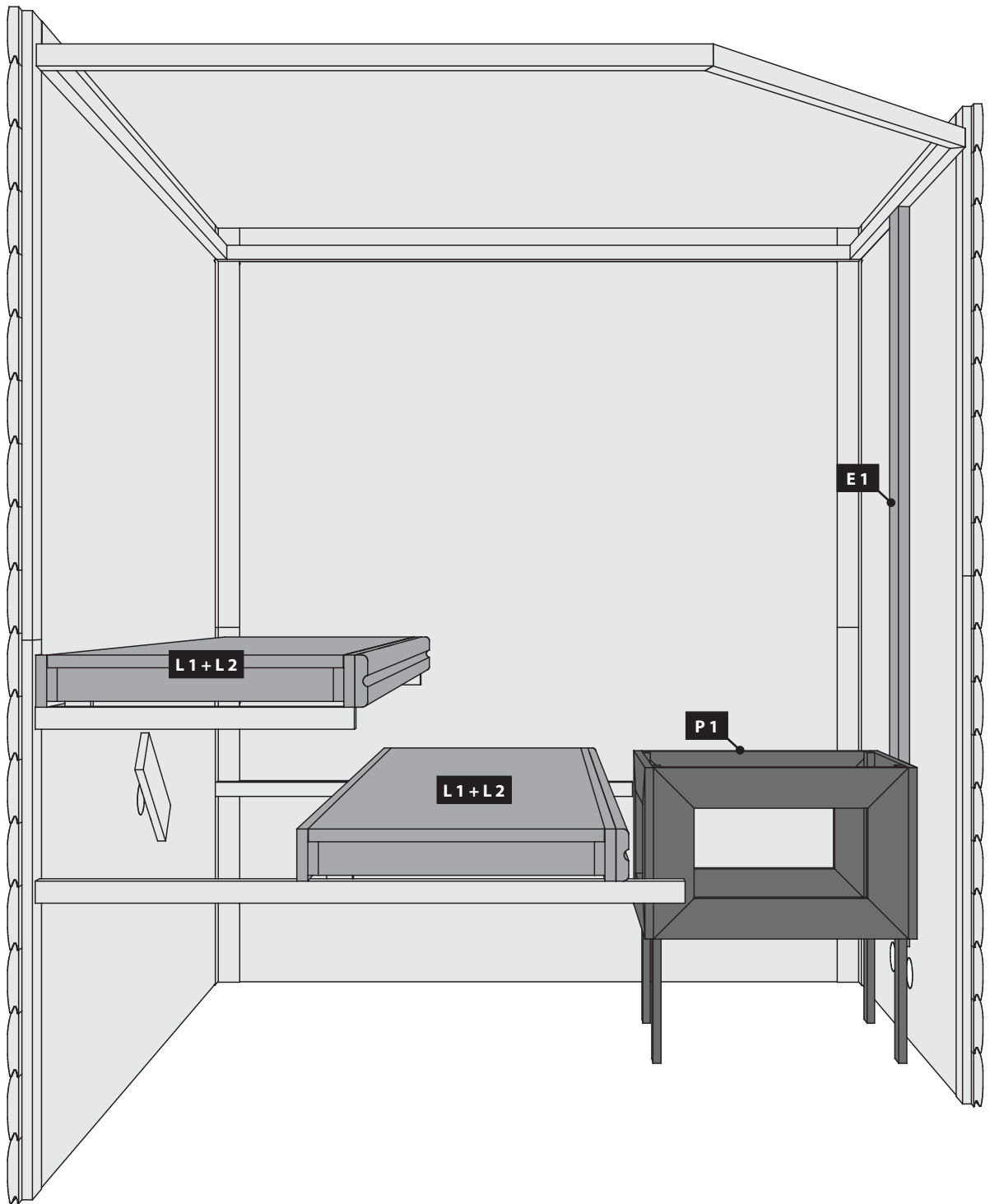

 Einbau Glastür

 Montage van de glazen deur

 Installazione portello di vetro

 Montage porte en verre

 Montaje de la puerta de cristal

 Instalace skleněné dveře

 Installation of glass door

01

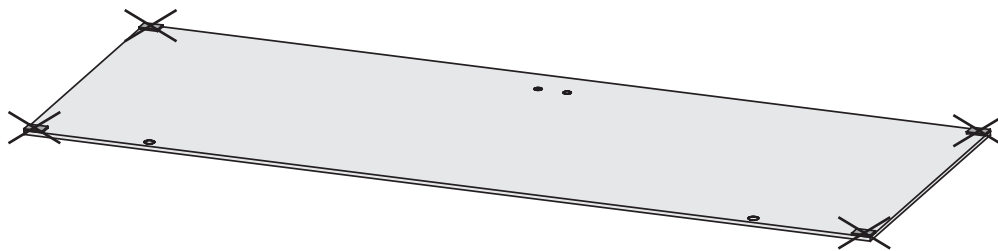

02

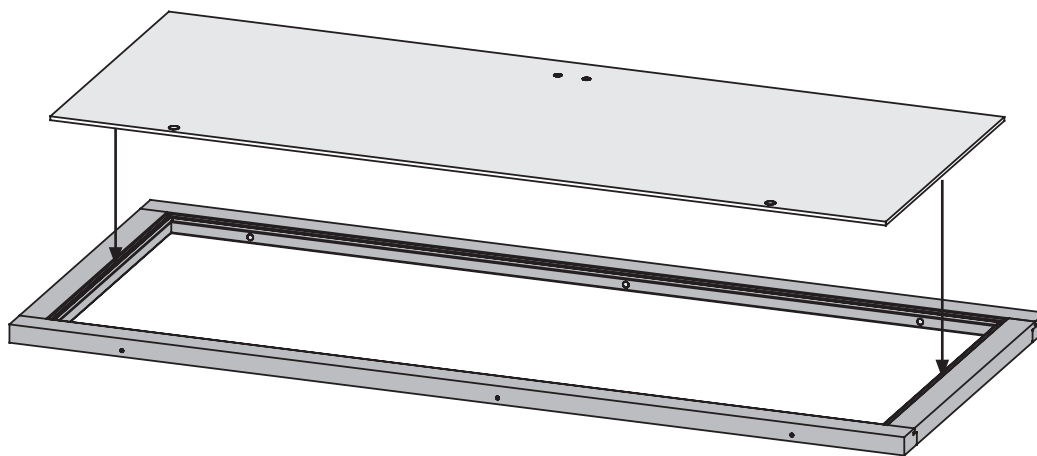

03

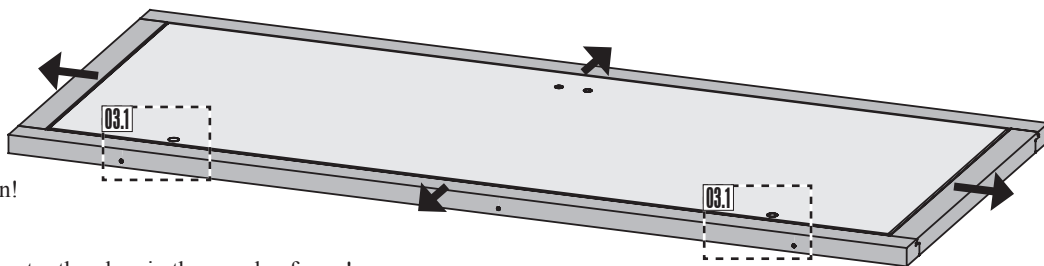

 Das Saunatürglas im Türrahmen ausrichten!

 Bien aligner le verre à vitre!

 To start building up the door you need to center the glass in the wooden frame!

 Plaats het glas van de sauna deur in het midden van het kozijn!

 ¡Centrar la puerta de cristal dentro del marco!

 Allineare il vetro dello sportello sauna al telaio della porta!

 Skleněná dvířka sauna v zárubně zarovnáni!

03.1-1

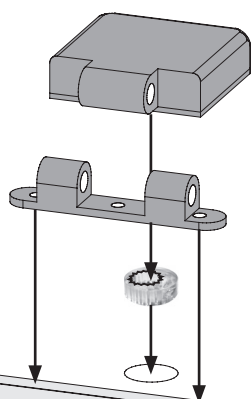

03.1-2

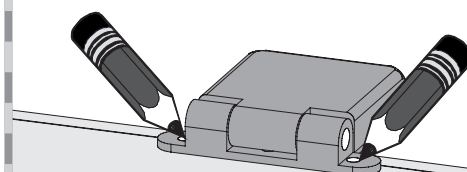

03.1-3

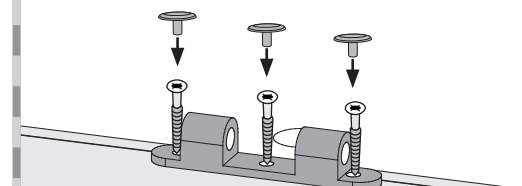

 Einbau Glastür

 Montage van de glazen deur

 Installazione portello di vetro

 Montage porte en verre

 Montaje de la puerta de cristal

 Instalace skleněné dveře

 Installation of glass door

04

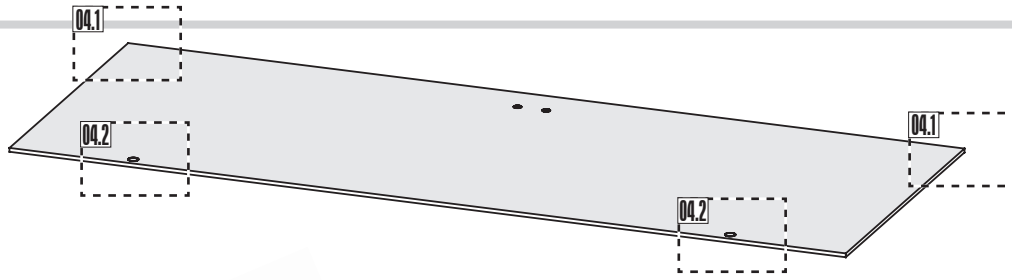

04.1-1

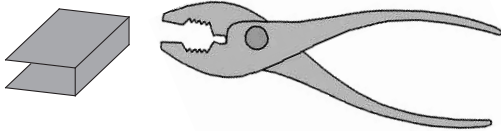

04.1-2

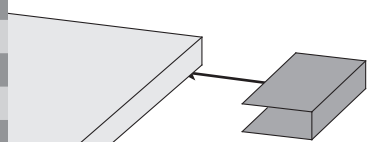

04.1-3

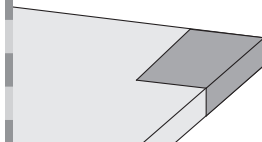

04.2-1

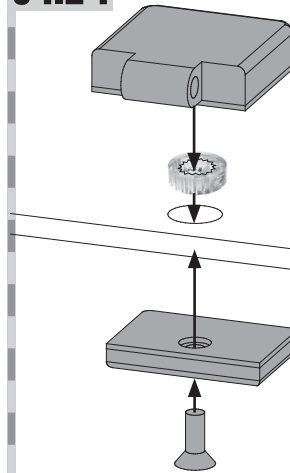

04.2-2

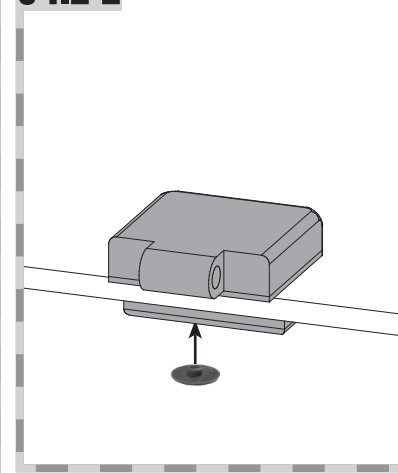

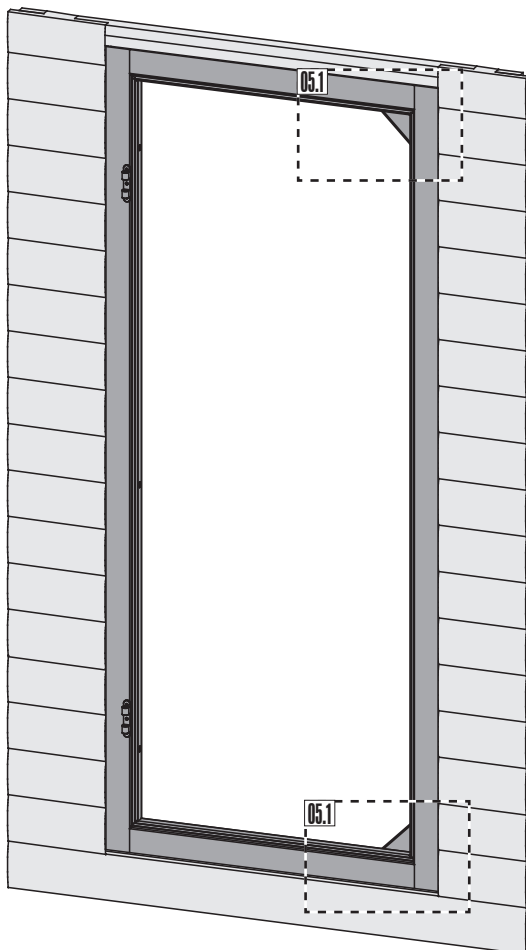

05





 Achtung: Alle Verstell-Excenter müssen in der Glasscheibe die gleiche Grundstellung haben!

 Attention: Tous les excentriques de positionnement doivent avoir la même position de base dans la vitre!

 Attention: All adjustable eccentrics must have the same basic adjustment in the glass panel!

 Attentie: alle excentrische verstelelementen moeten in dezelfde stand in de glasplaat worden geplaatst!

 Atención: Todos los excéntricos regulables tienen que tener la misma posición base en la hoja de cristal.

 Attenzione: Tutti gli eccentrici di regolazione devono avere la stessa posizione base nella lastra di vetro!

 Poznámka: Všechny nastavovací podivínů musí mít stejný základní polohy ve skle!

05.1-1



05.1-2



 Einbau Glastür

 Montage van de glazen deur

 Installazione portello di vetro

 Montage porte en verre

 Montaje de la puerta de cristal

 Instalace skleněné dveře

 Installation of glass door

06

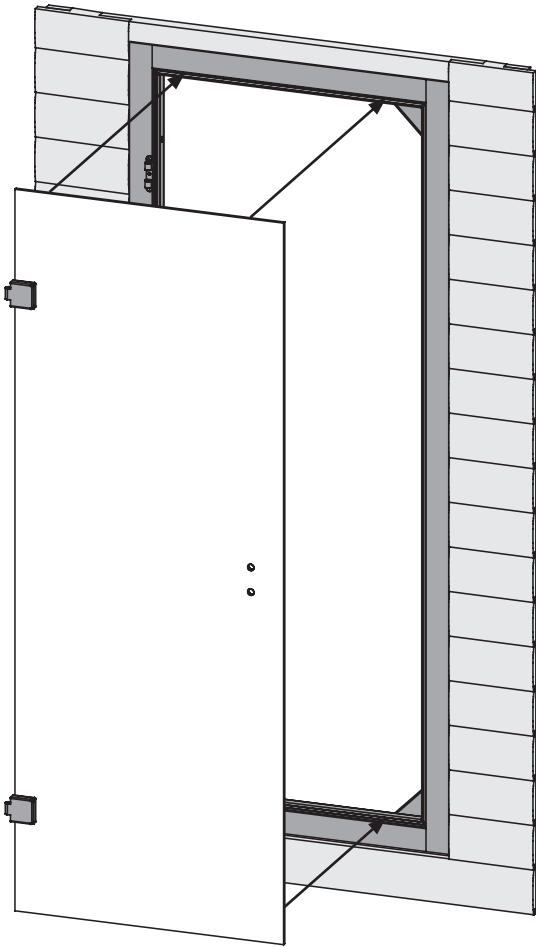

07

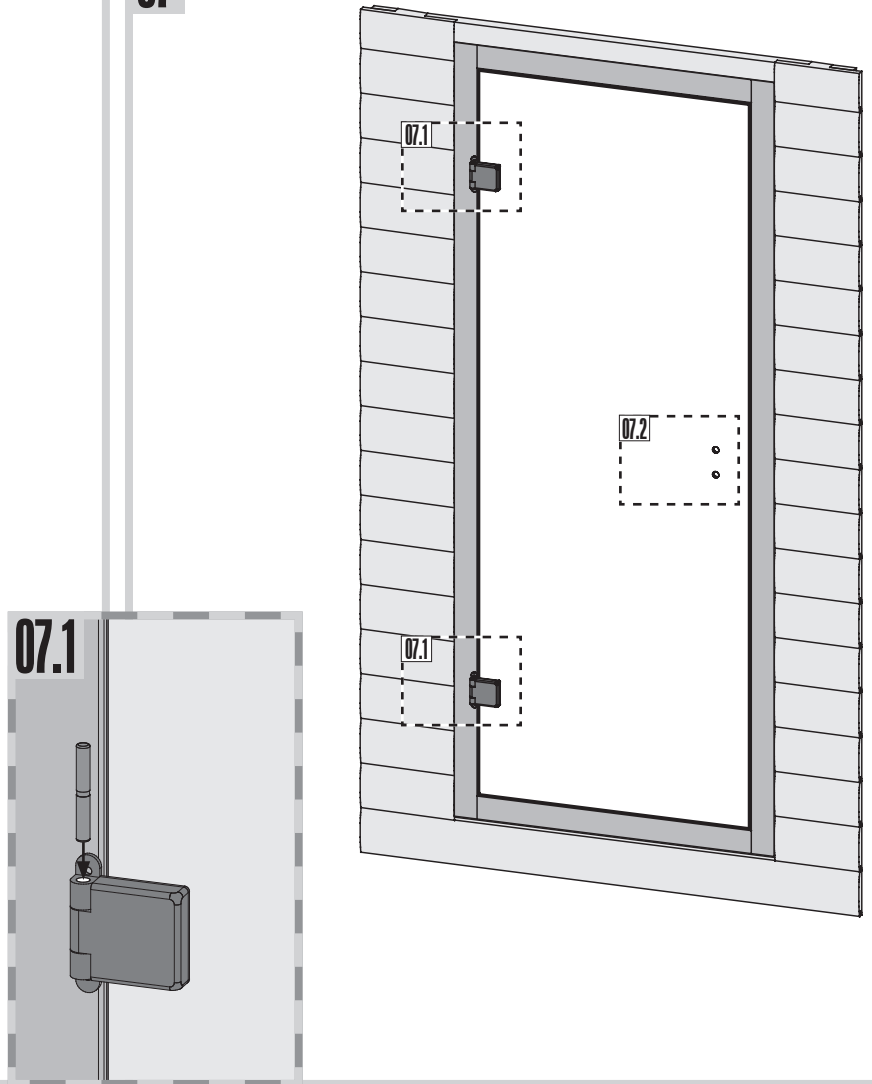

07.2-1

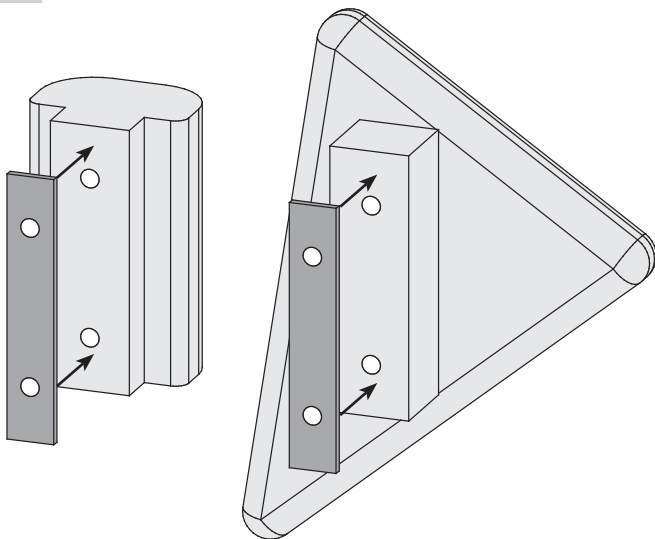

07.2-2

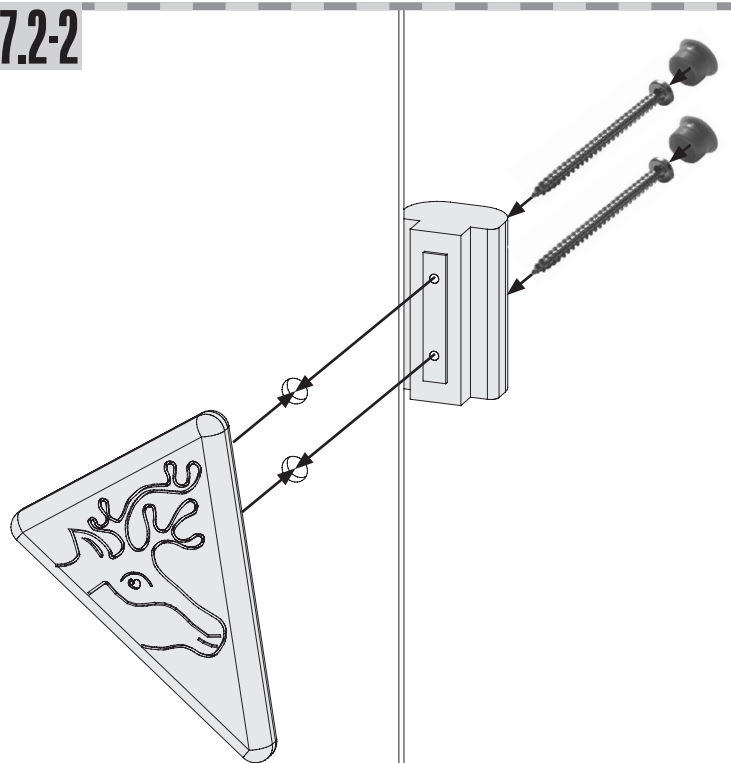

 Einbau Glastür

 Montage van de glazen deur

 Installazione portello di vetro

 Montage porte en verre

 Montaje de la puerta de cristal

 Instalace skleněné dveře

 Installation of glass door

08

 **Seitenverstellung + Höhenverstellung**

Achtung: Alle Verstell-Excenter müssen in der Glasscheibe die gleiche Grundstellung haben!

 **Positionnement latéral + positionnement hauteur**

Attention: Tous les excentres de positionnement doivent avoir la même position de base dans la vitre!

 **Lateral adjustment + height adjustment**

Attention: All adjustable eccentrics must have the same basic adjustment in the glass panel!

 **Zijverstelling + hoogteverstelling**

Attentie: alle excentrische verstelelementen moeten in dezelfde stand in de glasplaat worden geplaatst!

 **Regulación lateral + regulación de la altura**

Atención: Todos los excéntricos regulables tienen que tener la misma posición base en la hoja de cristal.

 **Regolazione laterale + regolazione dell'altezza**

Attenzione: Tutti gli eccentrici di regolazione devono avere la stessa posizione base nella lastra di vetro!

 **Boční nastavení + nastavení výšky**

Poznámka: Všechny nastavovací podivínů musí mít stejný základní polohy ve skle!

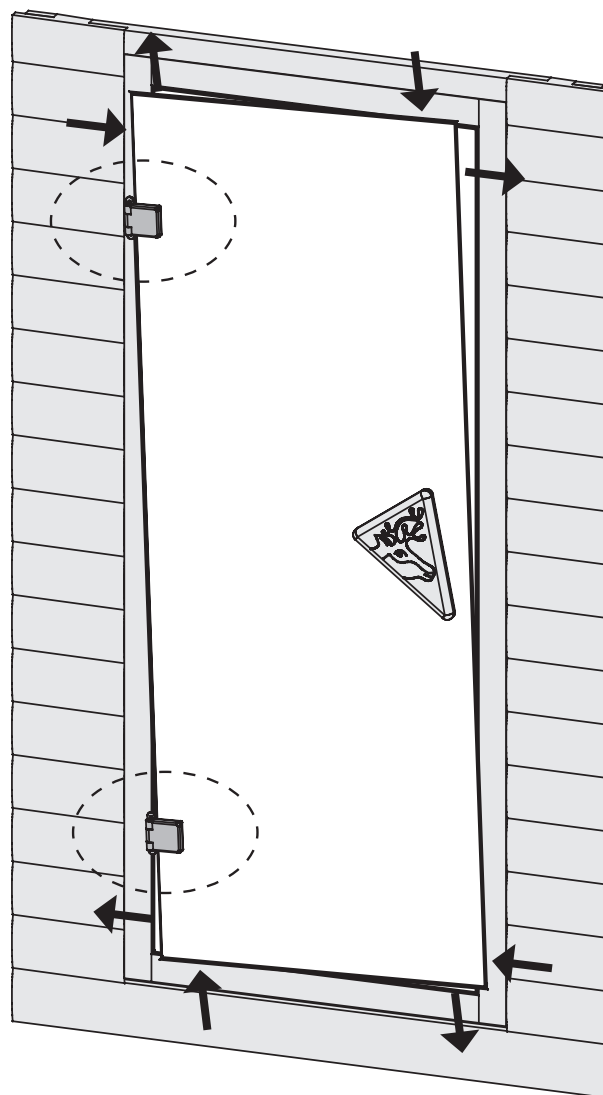
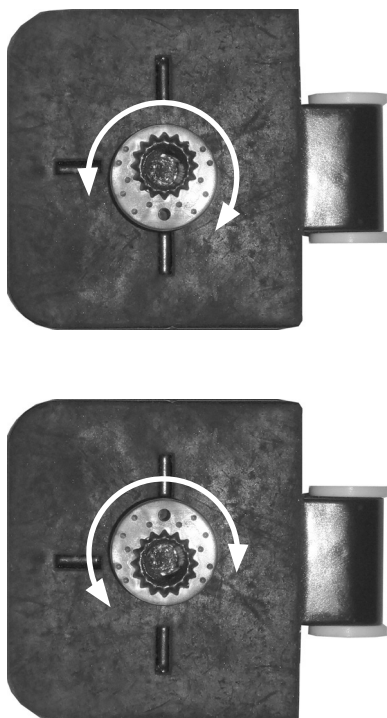

 Installation TÜV-Schild

 Installatie TÜV Shield

 Instalace TÜV Shield

 Installation TÜV Shield

 Installazione TÜV Shield

 Namestitev TÜV tablice

 Installation TÜV Shield

 Instalación TÜV Escudo





 Entfernen Sie die Schutzfolie vom beiliegenden TÜV-Schild. Lassen Sie den Saunaofen von einem zugelassenen Elektrofachmann anschließen. Dieser markiert den installierten Ofen auf dem TÜV-Schild. Bringen Sie das TÜV-Schild an einer gut sichtbaren Stelle über dem Ofen an.

 Remove the protective film from the accompanying Participate Schild. Lassen connecting the heater by a licensed electrician. This marks the installed furnace on the TÜV sign. Attach the TÜV sign at a conspicuous place on the stove.

 Retirez le film protecteur de l'accompagnant Participer Schild. Lassen raccorder l'appareil par un électricien agréé. Ceci marque le four installé sur le signe TÜV. Fixer le signe de TÜV à un endroit bien en vue sur le poêle.

 Verwijder de beschermfolie van de begeleidende Deelnemen Schild. Lassen het aansluiten van de kachel, door een erkende elektricien. Dit markeert de geïnstalleerde oven op het TÜV teken. Bevestig de TÜV teken op een opvallende plaats op het fornuis.

 Rimuovere la pellicola protettiva dal accompagna Partecipa Schild. Lassen collegando il riscaldatore da un elettricista qualificato. Questo segna il forno installato sul segno TÜV. Fissare il segno TÜV in un luogo ben visibile sulla stufa.

 Retire la película protectora de la Schild. Lassen acompaña Participar conectar el calentador por un electricista autorizado. Esto marca el horno instalado en el signo TÜV. Coloque el cartel de TÜV en un lugar visible en la estufa.

 Odstraňte ochrannou fólii z doprovodného Hlavní Schild. Lassen připojení ohřivače licencovaným elektrikář. Toto označí Instalovaný pec na znamení TÜV. Připevněte znamení TÜV na dobře viditelném místě na sporáku.

 S priložene tablice odstranite zaščitno folijo. Peč savne naj priključi usposobljeno osebje, ki inštalirano peč označi na TÜV tablici. Tablico namestite na vidno mesto peči.

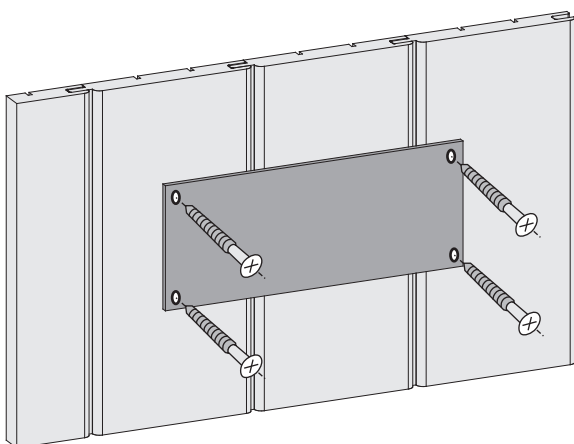
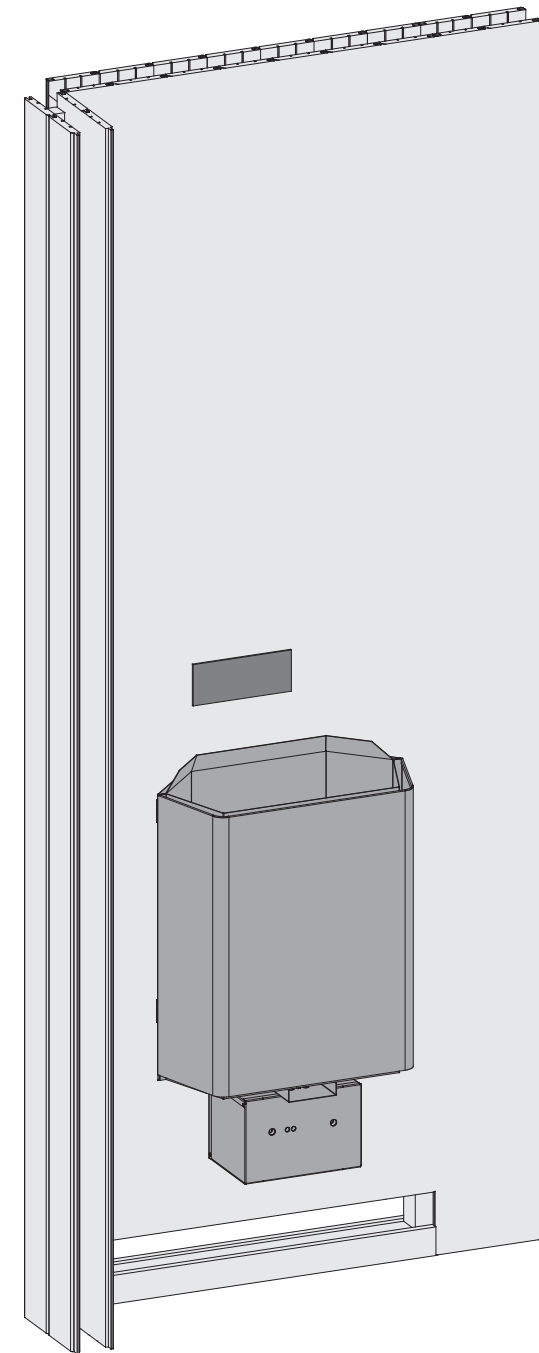

14016

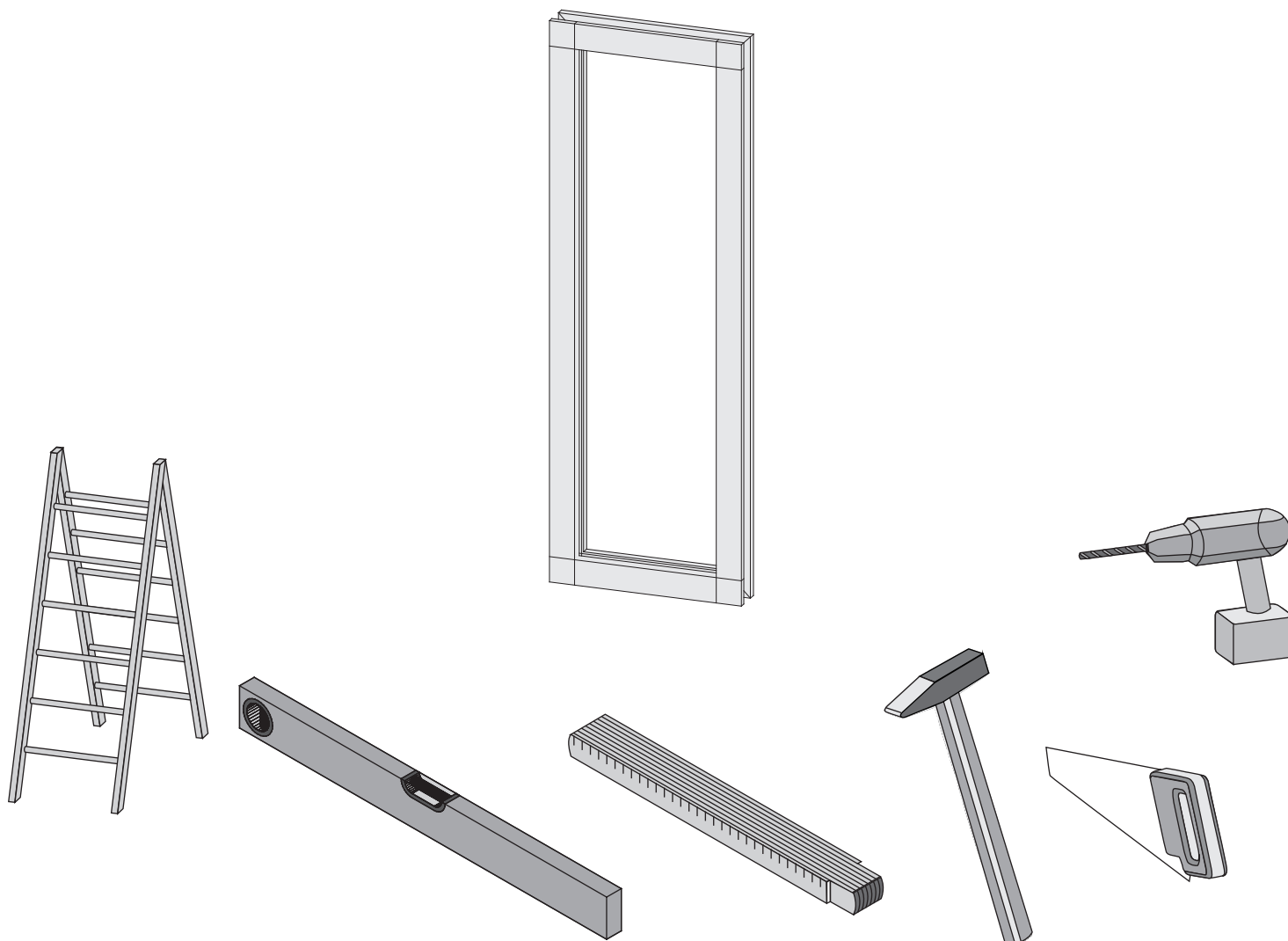

Aufbauanleitung



notice de montage



Building Instructions



montagehandleiding



Instrucciones de construcción



Istruzioni per il montaggio



Montážní návod

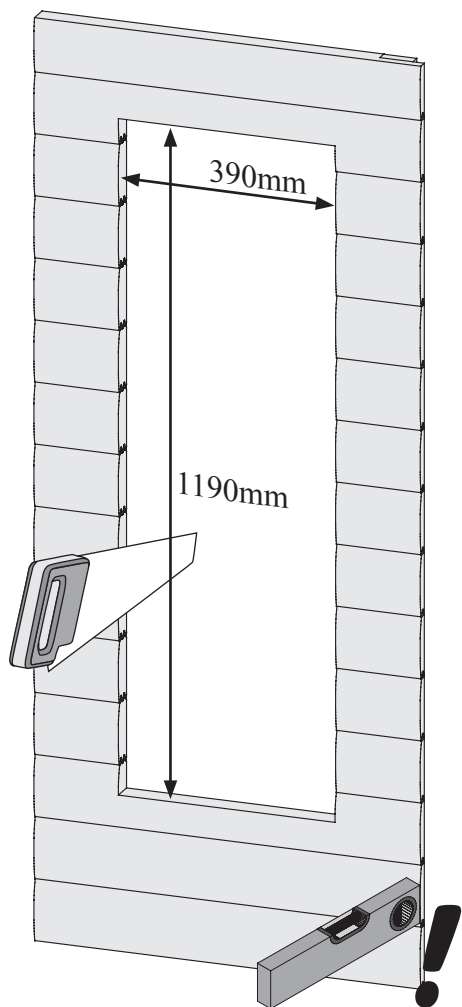
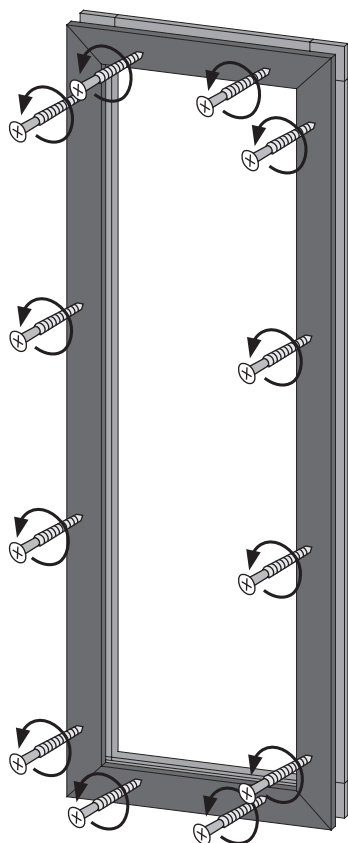
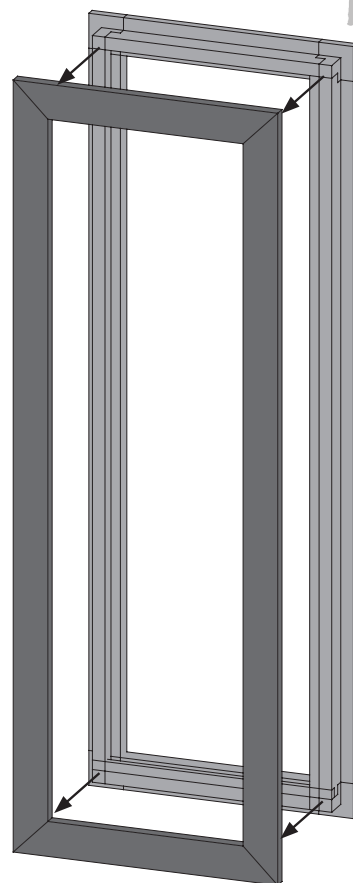
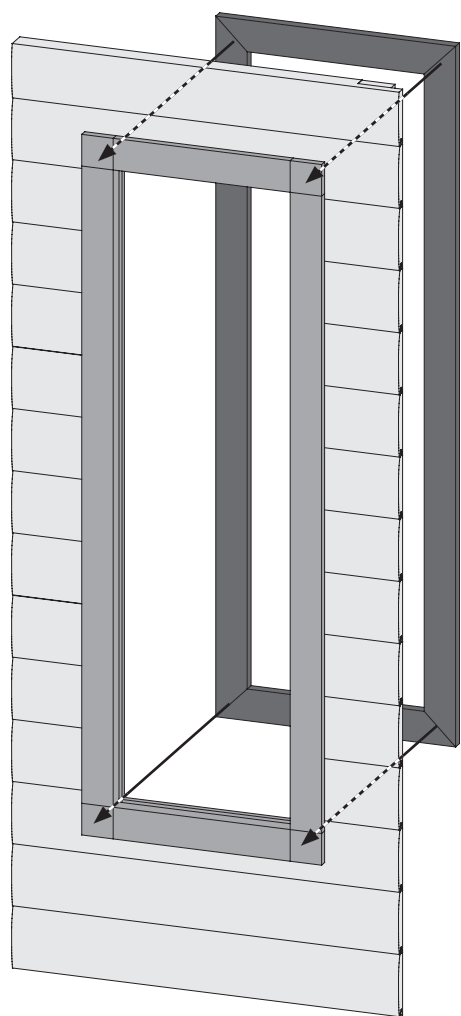
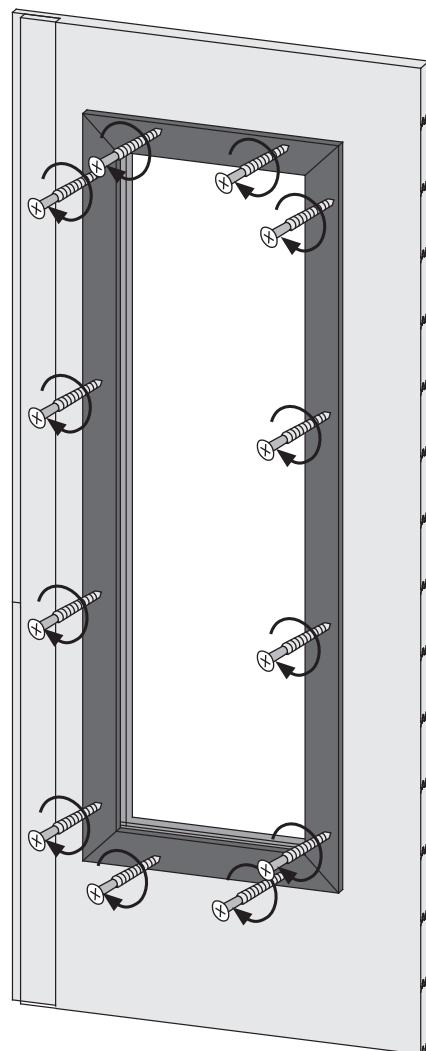

Service-Hotline: +49 421 38693 33

01**02****03****04****05**

75649

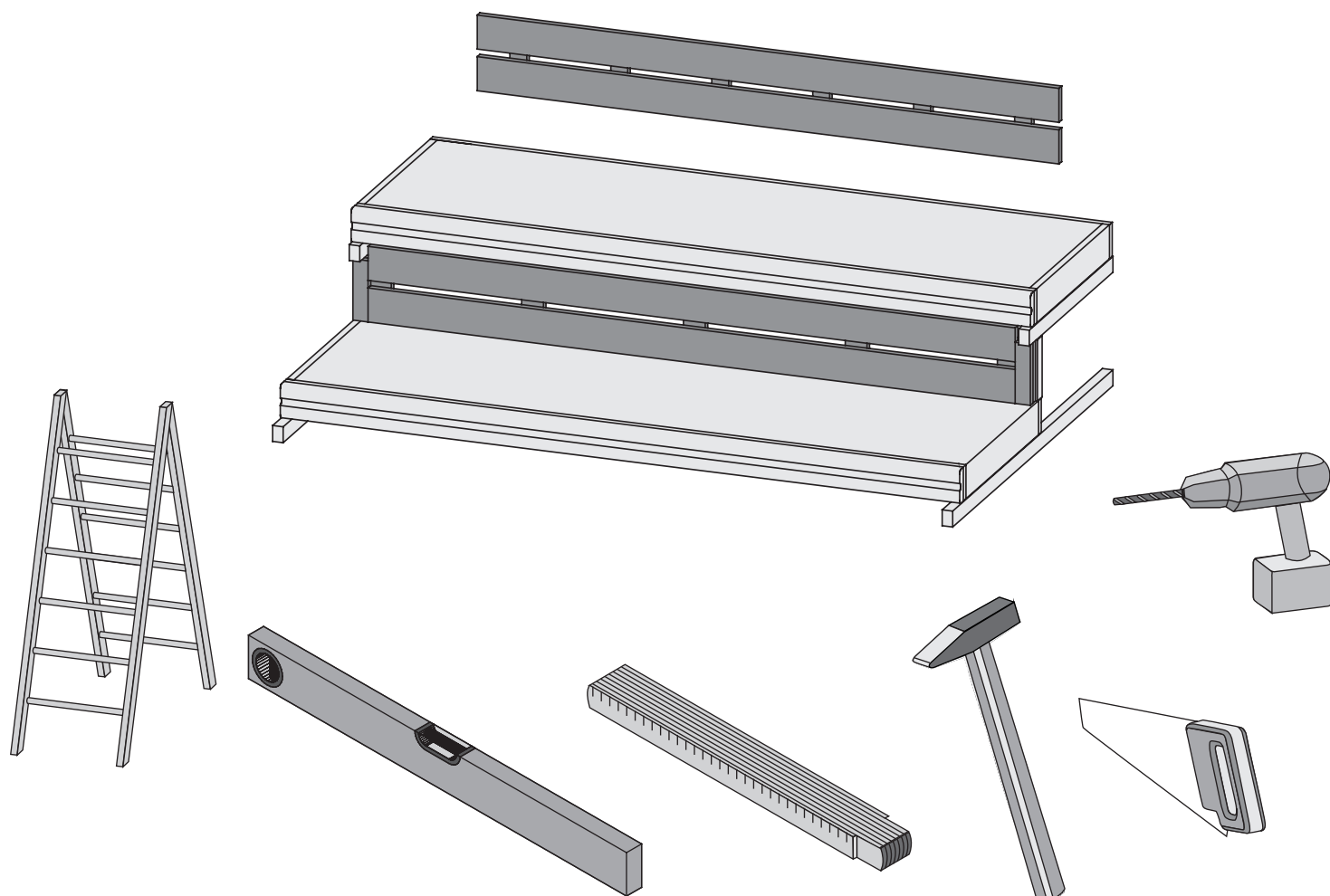

Aufbauanleitung



notice de montage



Building Instructions



montagehandleiding



Instrucciones de construcción



Istruzioni per il montaggio



Montážní návod



Service-Hotline: +49 421 38693 33



Vergleichen Sie zuerst die Materialliste mit Ihrem Paketinhalt! Bitte haben Sie Verständnis, dass Beanstandungen nur im nicht aufgebauten Zustand bearbeitet werden können!



En primer lugar, compare la lista de material con el contenido del paquete. Rogamos entienda que las reclamaciones sólo pueden ser tramitadas antes de montar el objeto!



Nejprve přezkontrolujte obsah balení podle materiálového listu! Mějte pochopení pro to, že případnou reklamaci se můžeme zabývat pouze tehdy, když díly nebudou smontované! Za pomoci tohoto seznamu můžete jednotlivé díly přiřadit k montážnímu návodu.



Vergelijk eerst de lijst van materialen met de inhoud van uw pakket! Reclamaties kunnen alleen in behandeling worden genomen zolang de onderdelen nog niet zijn gemonteerd!



First compare the list of materials with your package contents! Please understand that complaints can be processed in the non-built status only!



Commencez par comparer la liste du matériel avec le contenu de votre paquet! Sachez que nous traitons uniquement les réclamations concernant le matériel à l'état non monté!



Confrontate questa distinta materiali prima con il contenuto del pacchetto! Vi preghiamo di comprendere che eventuali reclami possono essere accolti solo prima del montaggio!



75649

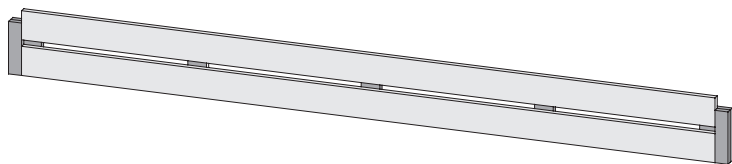

1 x B1

2151 x 200 x 37 mm

ID 27271

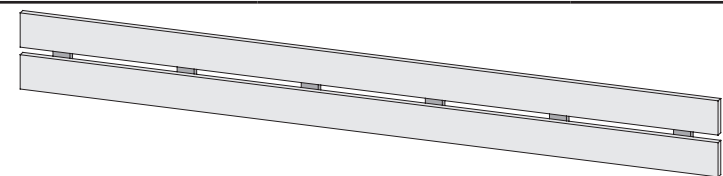

1 x R1

1550 x 200 x 37 mm

ID 75641

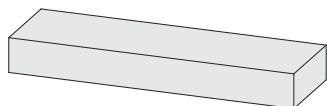

2 x A1

160 x 42 x 28 mm

ID 25058

20 x



ID 26116

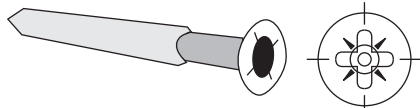

20 x

4,5 x 50 mm

ID 27179

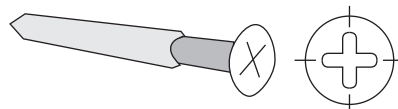

4 x

4 x 50 mm

ID 3688

4 x

4 x 70 mm

ID 3689

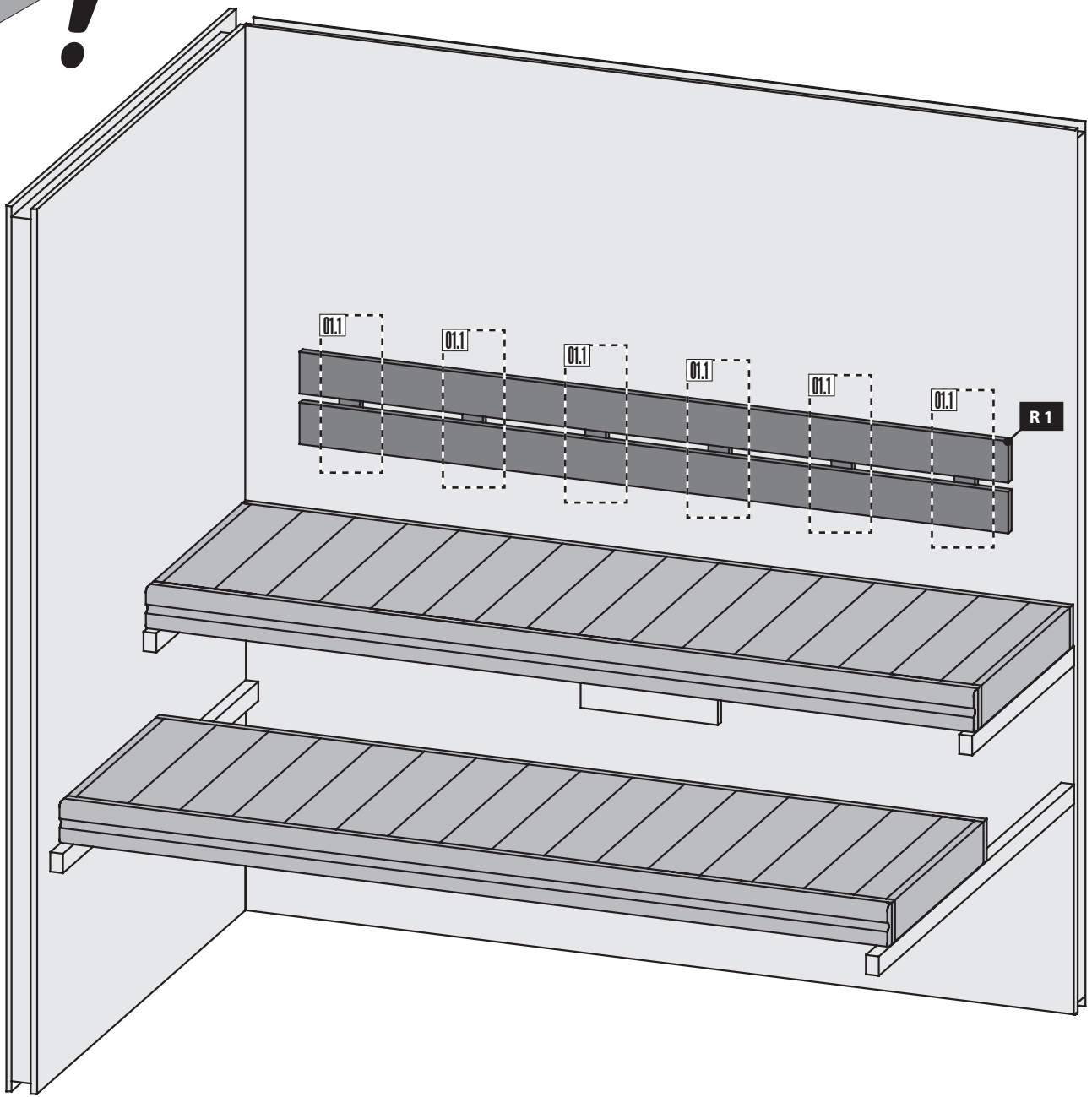
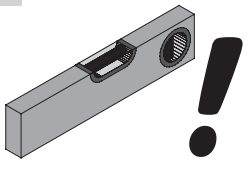

01.1-1

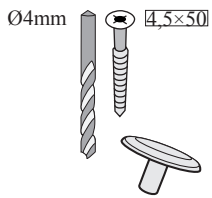
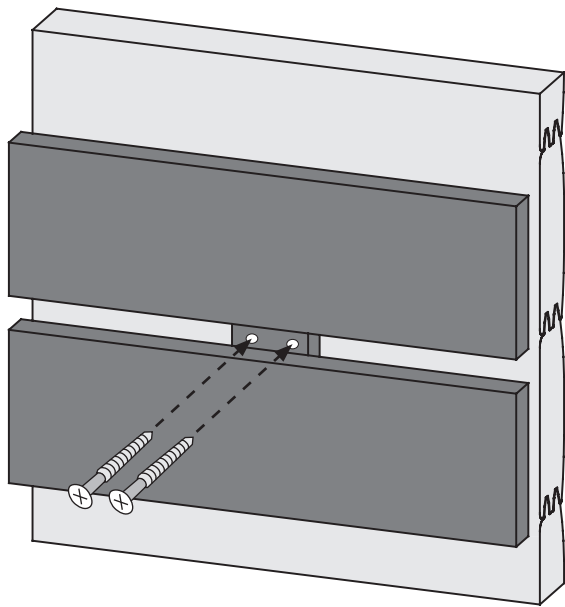

01.1-2

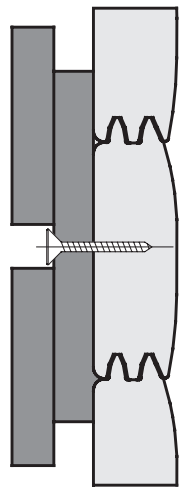

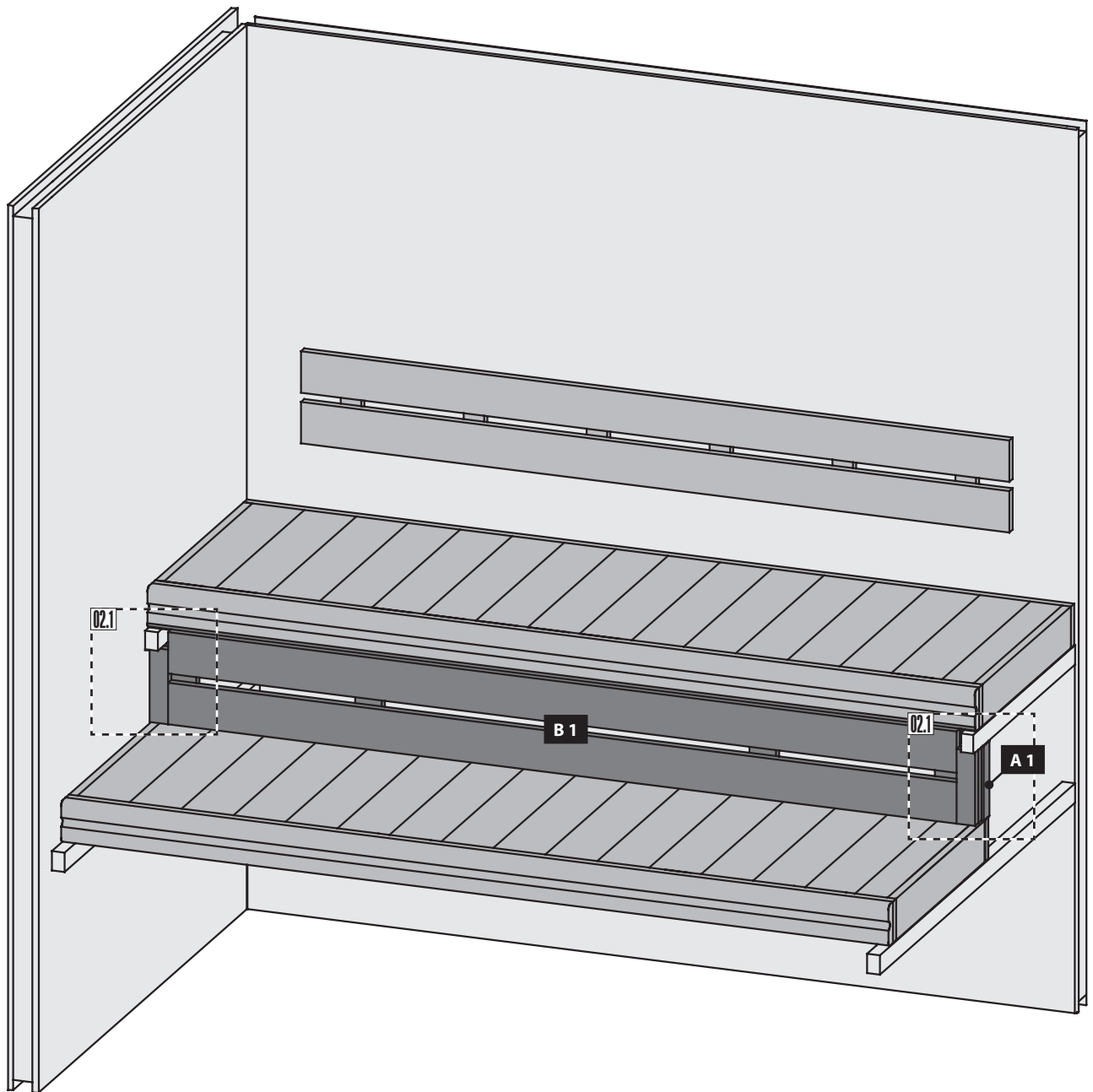

02.1-1

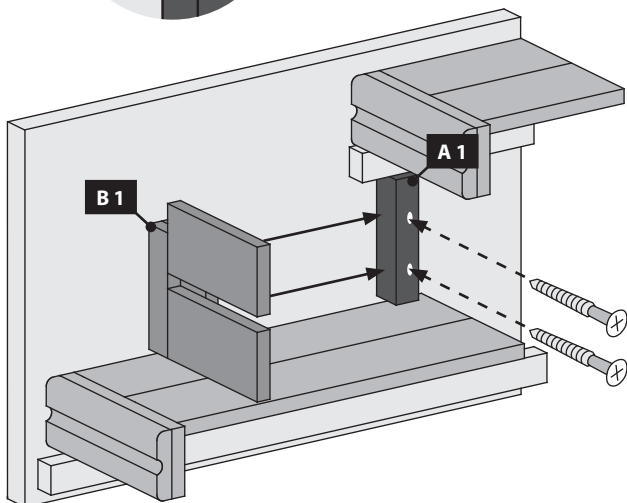
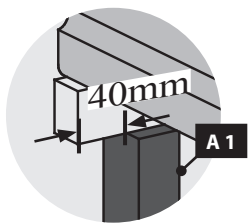
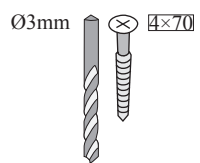

02.1-2

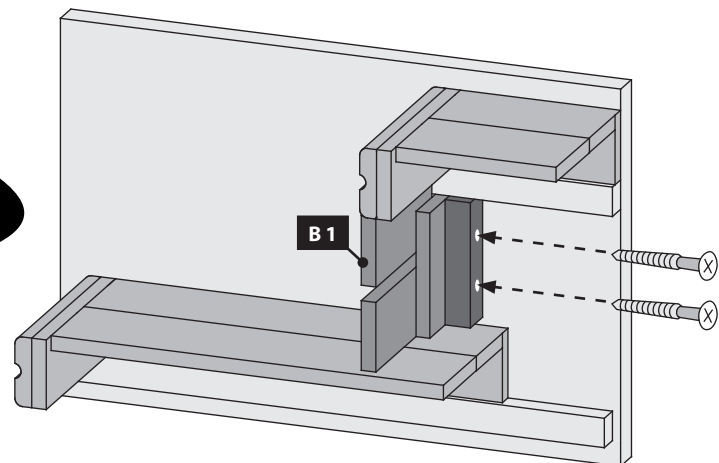
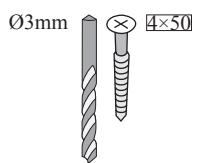

40598



Aufbauanleitung



notice de montage



Building Instructions



montagehandleiding



Instrucciones de construcción



Istruzioni per il montaggio



Montážní návod



Service-Hotline: +49 421 38693 33



Vergleichen Sie zuerst die Material-liste mit Ihrem Paketinhalt! Bitte haben Sie Verständnis, dass Beanstandungen nur im nicht aufgebauten Zustand bearbeitet werden können!



En primer lugar, compare la lista de material con el contenido del paquete. Rogamos entienda que las reclamaciones sólo pueden ser tramitadas antes de montar el objeto!



Nejprve překontrolujte obsah balení podle materiálového listu! Mějte pochopení pro to, že případnou reklamaci se můžeme zabývat pouze tehdy, když díly nebudou smontované! Za pomoci tohoto seznamu můžete jednotlivé díly přiřadit k montážnímu návodu.



Vergelijk eerst de lijst van materialen met de inhoud van uw pakket! Reclamaties kunnen alleen in behandeling worden genomen zolang de onderdelen nog niet zijn gemonteerd!



First compare the list of materials with your package contents! Please understand that complaints can be processed in the non-built status only!



Commencez par comparer la liste du matériel avec le contenu de votre paquet! Sachez que nous traitons uniquement les réclamations concernant le matériel à l'état non monté!



Confrontate questa distinta materiali prima con il contenuto del pacchetto! Vi preghiamo di comprendere che eventuali reclami possono essere accolti solo prima del montaggio!

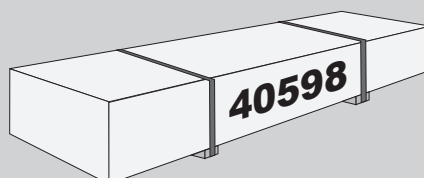

4 x A1	2040 x 140 x 26mm	ID 26185
1 x A2	2040 x 140 x 26mm	ID 26190
1 x A3	2040 x 140 x 26mm	ID 26191
4 x B1	498 x 140 x 26mm	ID 26192
5 x B2	579 x 140 x 26mm	ID 40617
1 x C1	498 x 30 x 30mm	ID 26198
70 x	4,5 x 60mm	ID 26199
70 x S3	4,5 x 30mm	ID 26116

01

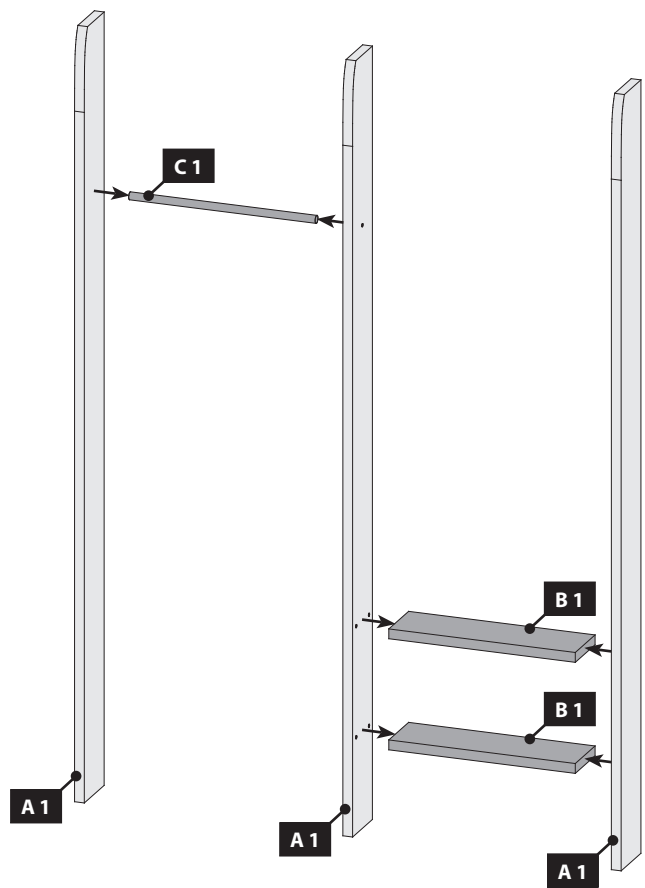

02

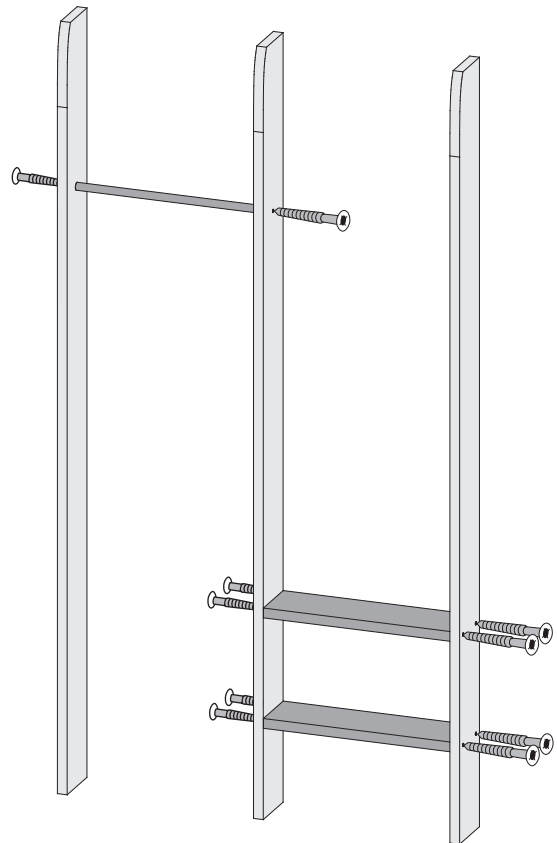
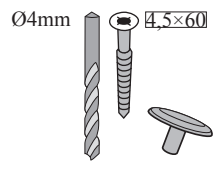

03



04

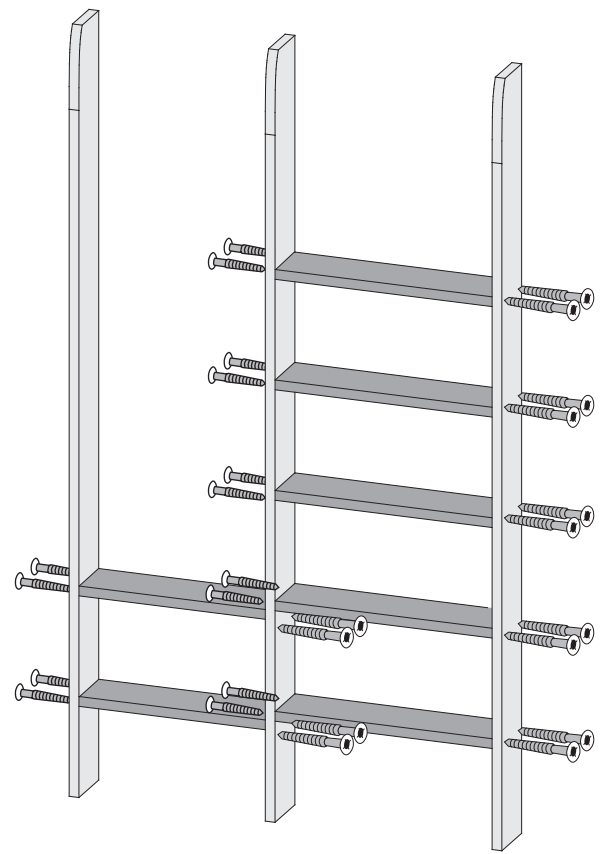
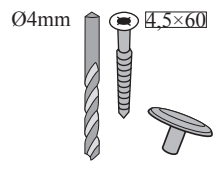

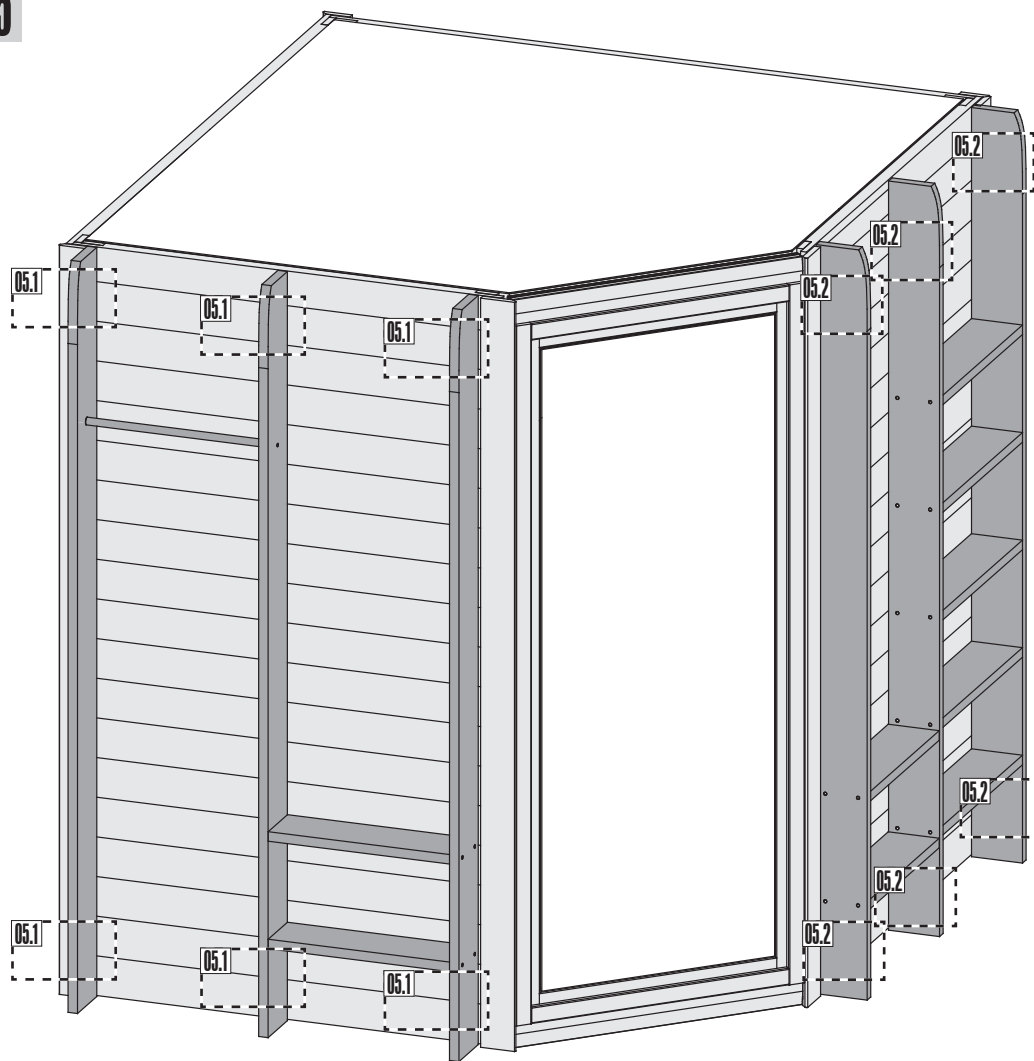

Ø4mm 4,5×60

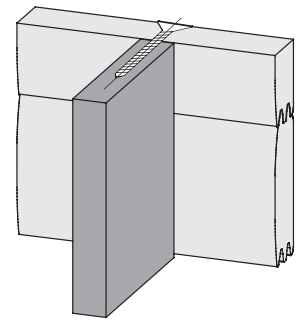

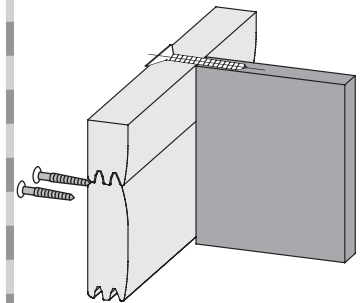

Ø4mm 4,5×60



 Achten Sie beim Vorbohren immer auf bereits verlegte Elektroleitungen.

 Lors de percements préalables, faites toujours attention aux lignes électriques déjà posées.

 During pre-drilling, always make certain not to drill into preinstalled electrical cabling.

 Let bij het voorboren altijd op de reeds gelegde elektrische leidingen.

 Al pretaladrar, tenga en cuenta los conductos eléctricos ya tendidos.

 Prima di forare fare sempre attenzione alla presenza di cavi elettrici.