

PRESTIGE® PRO ELITE

Assembly Guide | Guide d'assemblage
Guía de montaje | Montageanleitung

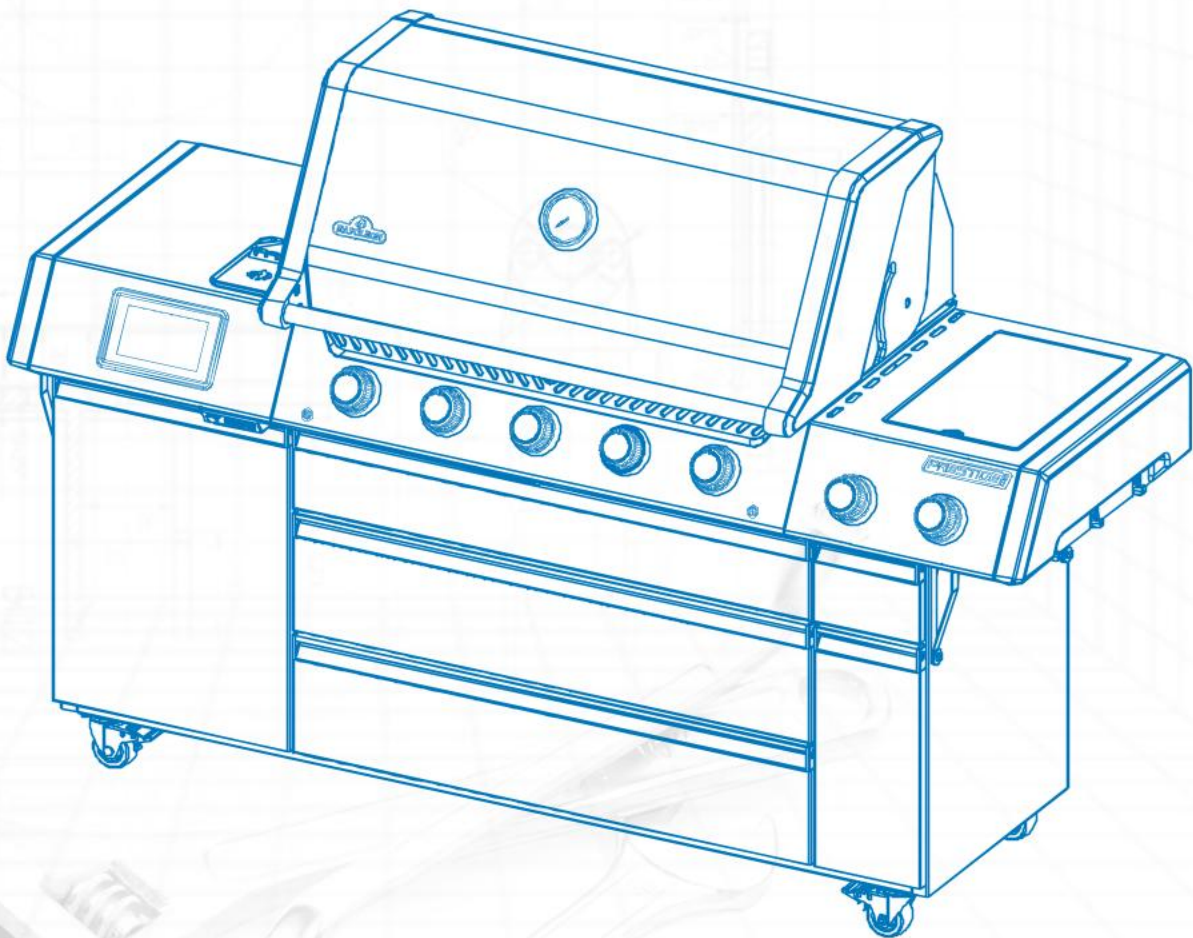

Model | Modèle | Modelo | Modell
PRO665VX

Actual product may differ from illustrations.
Le produit réel peut différer des illustrations.
El producto real puede diferir de las ilustraciones.
Das Produkt kann von den Abbildungen abweichen.



Assembly Guidelines

Safety equipment.

Équipement de sécurité.

Equipo de seguridad.

Schutzrüstung.



Tools requirements for installation (not included).

Outils nécessaires pour l'installation (non fournis).

Herramientas necesarias para la instalación (no incluidas).

Für die Installation benötigte Werkzeuge (nicht enthalten).

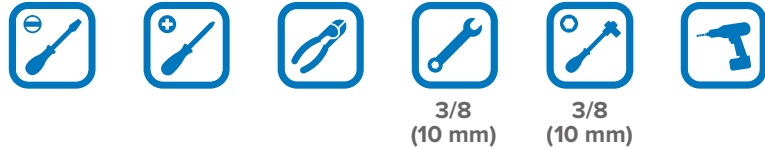

Legend



Warning!
Attention!
¡Advertencia!
Achtung!



Important.
Information!
Importante.
Wichtig.



Unlock.
Déverrouiller.
Desbloquear.
Entriegeln.



Rotate the unit.
Tourner l'appareil.
Girar la unidad.
Gerät drehen.



Lock.
Verrouiller.
Bloquear.
Verriegeln.



Lift.
Soulever.
Levantar.
Anheben.



Positioning.
Positionnement.
Posicionamiento.
Positionierung.



Tear away cardboard.
Déchirer le carton.
Rasgar el cartón.
Karton abreißen.



Look closely.
Regarder
attentivement.
Mirar con atención.
Schau genau hin.



Two persons.
Deux personnes.
Dos personas.
Zwei Personen.



First person.
Première personne.
Primera persona.
Erste-Person-
Aufgabe.



Second person.
Deuxième personne.
Segunda persona.
Zweite-Person-
Aufgabe.



Dispose of the waste.
Se débarrasser des
déchets.
Desechar los residuos.
Den Abfall entsorgen.



Do not dispose.
Ne pas jeter.
No desechar.
Nicht entsorgen.



Repeat last step
Répéter la dernière
étape. Repetir el
último paso. Letzten
Schritt wiederholen.



Propane only.
Propane uniquement.
Solo propano.
Nur Propan.



Remove protective film and/or tape.
Retirez le film protecteur et/ou le ruban adhésif.
Retire la película protectora y/o la cinta adhesiva.
Entfernen Sie die Schutzfolie und/oder das
Klebeband.

WELCOME TO NAPOLEON®!

Congratulations on taking your grilling to the next level.
Welcome to the **NAPOLEON®** family!



Register your grill today.

We're here to accompany you through unforgettable moments.



IMPORTANT!

- Set up this assembly on a solid, level and horizontal surface.
- There may be visual differences between illustrations and model purchased.

BIENVENUE À NAPOLEON®!

Félicitations pour avoir franchi une nouvelle étape dans l'art du barbecue. Bienvenue dans la famille **NAPOLEON®**!



Enregistrez votre barbecue dès aujourd'hui.

Nous sommes là pour vous accompagner dans vos moments inoubliables.



IMPORTANT !

- Installez cet assemblage sur une surface solide, plane et horizontale.
- Il peut y avoir des différences visuelles entre les illustrations et le modèle acheté.

¡BIENVENIDOS A NAPOLEON®!

Enhorabuena por llevar tus habilidades con la barbacoa al siguiente nivel. ¡Bienvenido a la familia **NAPOLEON®**!



Registre su parrilla hoy mismo.

Estamos aquí para acompañarle en momentos inolvidables.



¡IMPORTANTE!

- Instale este conjunto sobre una superficie sólida, nivelada y horizontal.
- Puede haber diferencias visuales entre las ilustraciones y el modelo adquirido.

WILLKOMMEN BEI NAPOLEON®!

Herzlichen Glückwunsch, Sie haben Ihr Grillerlebnis auf das nächste Level gebracht. Willkommen in der **NAPOLEON®**-Familie!



Registrieren Sie Ihren Grill noch heute.

Wir begleiten Sie bei unvergesslichen Momenten.



WICHTIG!

- Führen Sie die Montage auf einer festen, ebenen und waagerechten Fläche durch.
- Zwischen den Abbildungen und dem gekauften Modell kann es zu optischen Abweichungen kommen.

VELKOMMEN TIL NAPOLEON®!

Tillykke med at tage din grilloplevelse til næste niveau. Velkommen til **NAPOLEON®** - familien!



Registrer din grill i dag.

Vi er her for at ledsage dig gennem uforglemmelige øjeblikke.



VIGTIGT!

- Opsæt denne montering på en solid, plan og vandret overflade.
- Der kan være visuelle forskelle mellem illustrationer og den købte model.

WELKOM BIJ NAPOLEON®!

Gefeliciteerd met het naar een hoger niveau tillen van je grillervaring. Welkom bij de **NAPOLEON®**-familie!



Registreer je grill vandaag.

Wij zijn er om je te begeleiden bij onvergetelijke momenten.



BELANGRIJK!

- Voer deze montage uit op een stevige, vlakke en horizontale ondergrond.
- Er kunnen visuele verschillen zijn tussen de illustraties en het gekochte model.

VÍTEJTE U NAPOLEON®!

Gratulujeme, že jste posunuli své grilování na vyšší úroveň. Vítejte v rodině **NAPOLEON®!**



Zaregistrujte svůj gril ještě dnes.

Jsme tu, abychom vás provázeli nezapomenutelnými okamžiky.



DŮLEŽITÉ!

- Sestavujte na pevné, rovné a vodorovné ploše.
- Mezi ilustracemi a zakoupeným modelem mohou být vizuální rozdíly.

TERVETULOA NAPOLEON®!

Onnittelut, että viet grillaamisen uudelle tasolle. Tervetuloa **NAPOLEON®**-perheeseen!



Rekisteröi grillisi jo tänään.

Olemme täällä luomassa unohtumattomia hetkiä kanssasi.



TÄRKEÄÄ!

- Suorita kokoaminen tukevalla, tasaisella ja vaakasuoralla pinnalla.
- Kuvien ja ostetun mallin välillä voi olla visuaalisia eroja.

ΚΑΛΩΣ ΗΡΘΑΤΕ ΣΤΗΝ NAPOLEON®!

Συγχαρητήρια που ανεβάσατε το ψήσιμο σε άλλο επίπεδο. Καλώς ήρθατε στην οικογένεια **NAPOLEON®!**



Καταχωρήστε τη ψησταριά σας σήμερα.

Είμαστε εδώ για να σας συνοδεύσουμε σε αξέχαστες στιγμές.



ΣΗΜΑΝΤΙΚΟ!

- Στήστε τη συναρμολόγηση σε σταθερή, επίπεδη και οριζόντια επιφάνεια.
- Ενδέχεται να υπάρχουν οπτικές διαφορές μεταξύ των εικόνων και του αγορασμένου μοντέλου.

DOBRODOŠLI U NAPOLEON®!

Čestitamo što ste podigli roštiljanje na višu razinu.
Dobrodošli u obitelji **NAPOLEON®!**



Registrirajte svoj roštilj danas.

Ovdje smo da vas pratimo kroz nezaboravne trenutke.



VAŽNO!

- Postavite montažu na čvrstu, ravnu i vodoravnu površinu.
- Mogu postojati vizualne razlike između ilustracija i kupljenog modela.

BENVENUTO IN NAPOLEON®!

Congratulazioni per aver portato la tua esperienza di grigliata a un livello superiore. Benvenuto nella famiglia **NAPOLEON®!**



Registra oggi il tuo barbecue.

Siamo qui per accompagnarti in momenti indimenticabili.



IMPORTANTE!

- Esegui il montaggio su una superficie solida, piana e orizzontale.
- Potrebbero esserci differenze visive tra le illustrazioni e il modello acquistato.

VELKOMMEN TIL NAPOLEON®!

Gratulerer med å ta grillingen til neste nivå. Velkommen til **NAPOLEON®-familien!**



Registrer grillen din i dag.

Vi er her for å følge deg gjennom uforglemmelige øyeblikk.



VIKTIG!

- Utfør monteringen på en solid, jevn og horisontal overflate.
- Det kan være visuelle forskjeller mellom illustrasjoner og den kjøpte modellen.

WITAJ W NAPOLEON®!

Gratulacje za podniesienie grillowania na wyższy poziom. Witamy w rodzinie **NAPOLEON®**!



Zarejestruj swój grill już dziś.

Jesteśmy tutaj, aby towarzyszyć Ci w niezapomnianych chwilach.



WAŻNE!

- Przeprowadź montaż na solidnej, równej i poziomej powierzchni.
- Mogą występować różnice wizualne między ilustracjami a zakupionym modelem.

VÄLKOMMEN TILL NAPOLEON®!

Grattis till att ta din grillning till nästa nivå. Välkommen till **NAPOLEON®**-familjen!



Registrera din grill idag.

Vi finns här för att följa dig genom oförglömliga stunder.



VIKTIGT!

- Utför monteringen på en solid, jämn och horisontell yta.
- Det kan finnas visuella skillnader mellan illustrationerna och den köpta modellen.

DOBRODOŠLI V NAPOLEON®!

Čestitamo, da ste dvignili peko na žaru na višjo raven. Dobrodošli v družinia **NAPOLEON®**!



Registrirajte svoj žar še danes.

Tukaj smo, da vas spremljamo skozi nepozabne trenutke.



POMEMBNO!

- Sestavljanje izvedite na trdni, ravni in vodoravni površini.
- Med ilustracijami in kupljenim modelom so lahko vizualne razlike.

VITAJTE V NAPOLEON®!

Gratulujeme, že ste posunuli grilovanie na vyššiu úroveň.
Vitajte v rodine **NAPOLEON®!**



Zaregistrujte svoj gril ešte dnes.

Sme tu, aby sme vás sprevádzali nezabudnuteľnými okamihmi.



DÔLEŽITÉ!

- Montáž vykonajte na pevnom, rovnom a vodorovnom povrchu.
- Medzi ilustráciami a zakúpeným modelom môžu byť vizuálne rozdiely.

ЛАСКАВО ПРОСИМО ДО NAPOLEON®!

Вітаємо, що ви підняли грилювання на новий рівень.
Ласкаво просимо до родини **NAPOLEON®!**



Зареєструйте свій гриль сьогодні.

Ми тут, щоб супроводжувати вас у незабутні моменти.



ВАЖЛИВО!

- Виконуйте складання на міцній, рівній та горизонтальній поверхні.
- Можливі візуальні відмінності між ілюстраціями та придбаною моделлю.

ДОБРО ПОЖАЛОВАТЬ В NAPOLEON®!

Поздравляем с тем, что вы вывели гриль на новый уровень. Добро пожаловать в семью **NAPOLEON®!**



Зарегистрируйте свой гриль сегодня.

Мы здесь, чтобы сопровождать вас в незабываемые моменты.



ВАЖНО!

- Собирайте на прочной, ровной и горизонтальной поверхности.
- Могут быть визуальные различия между иллюстрациями и приобретенной моделью.

PRO665VX

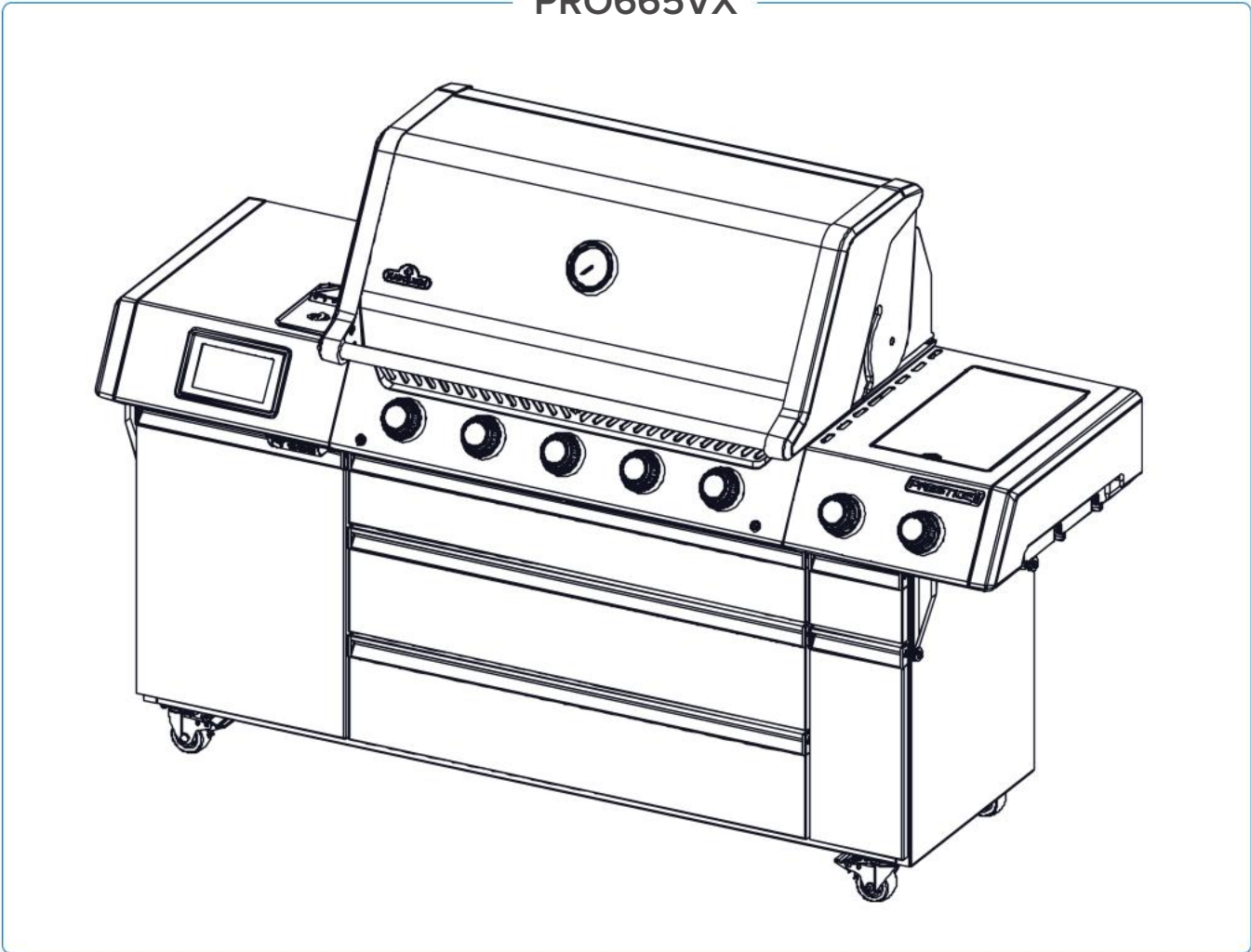

Packaging Overview
Schéma d'emballage
Esquema del empaque
Verpackungsübersicht

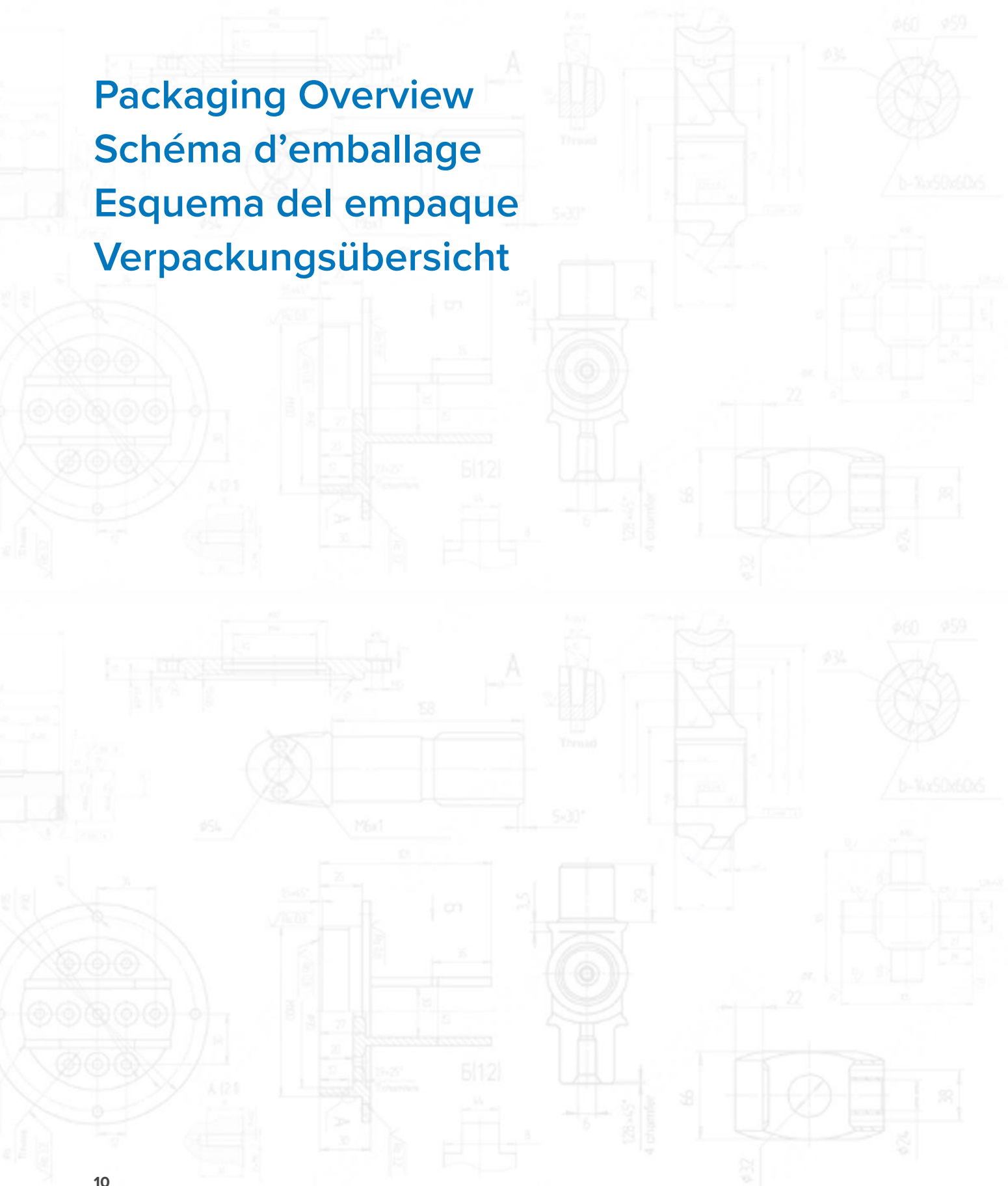

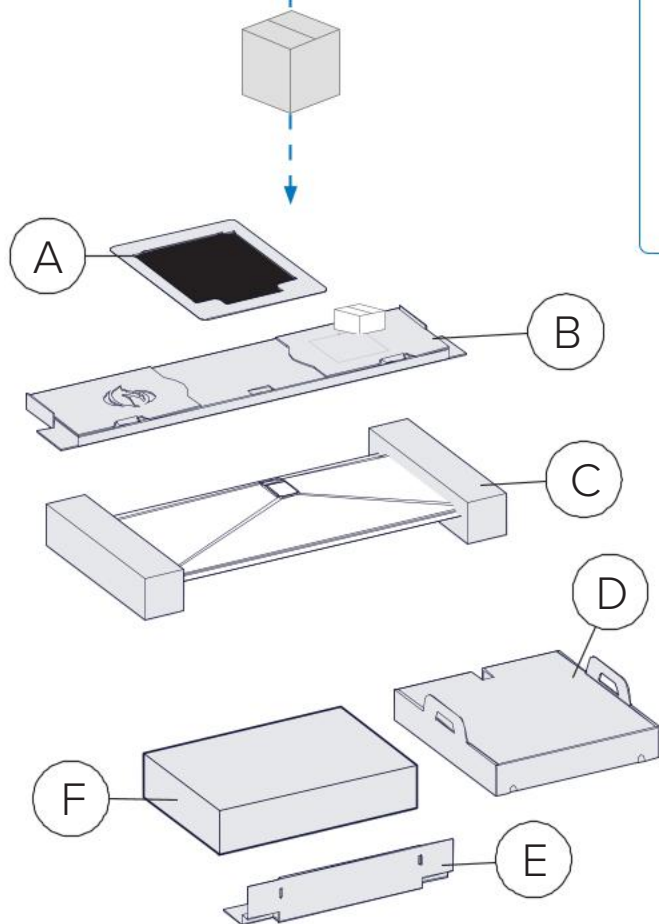
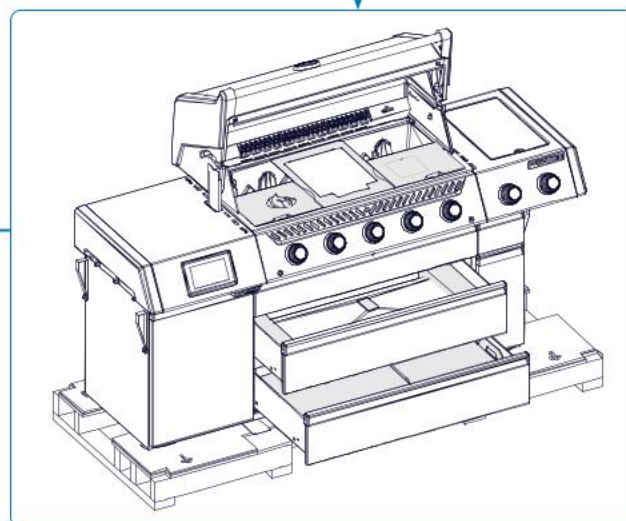
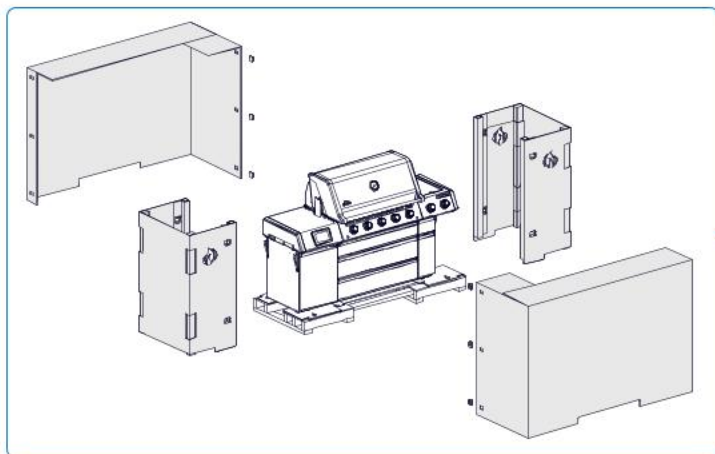

! **IMPORTANT!**
¡IMPORTANTE!
WICHTIG!

- Remove the appliance tape and kits before taking the unit off of the pallet (see assembly steps).
- Retirez le ruban adhésif et les accessoires de l'appareil avant de retirer l'unité de la palette (voir les étapes d'assemblage).
- Retire la cinta y los kits del aparato antes de sacar la unidad del palé (vea los pasos de ensamblaje).
- Entfernen Sie das Klebeband und die Zubehörsets, bevor Sie das Gerät von der Palette heben (siehe Montageschritte).

Assembly Steps

Étapes de l'installation

Pasos para la instalación

Montageschritte



1

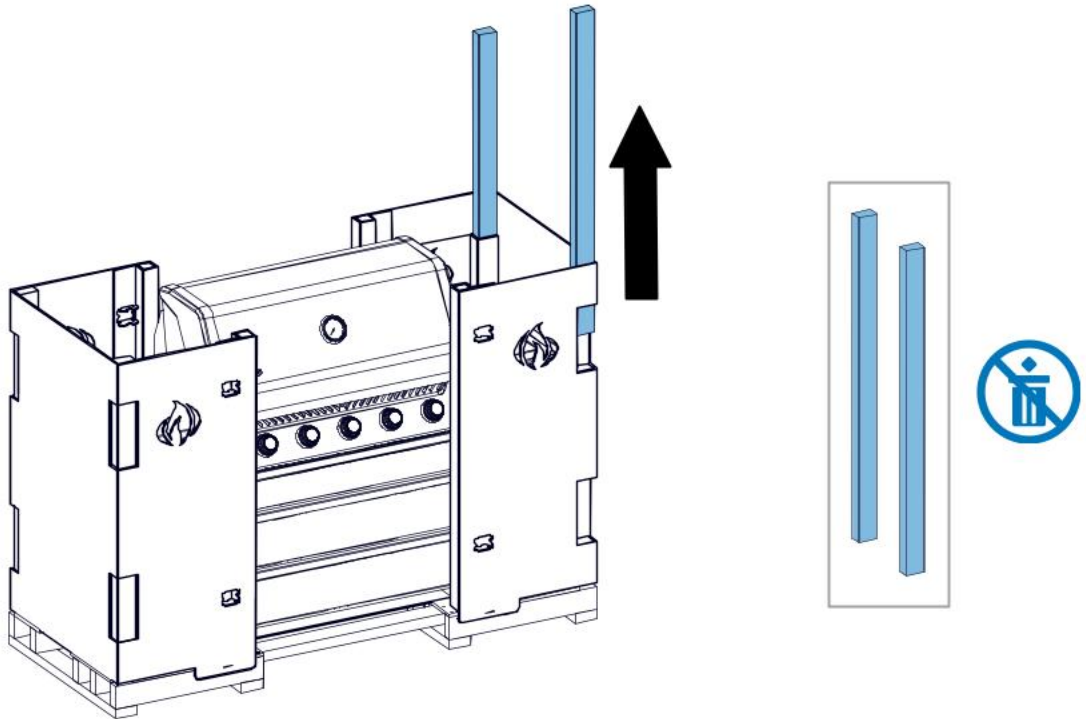

2

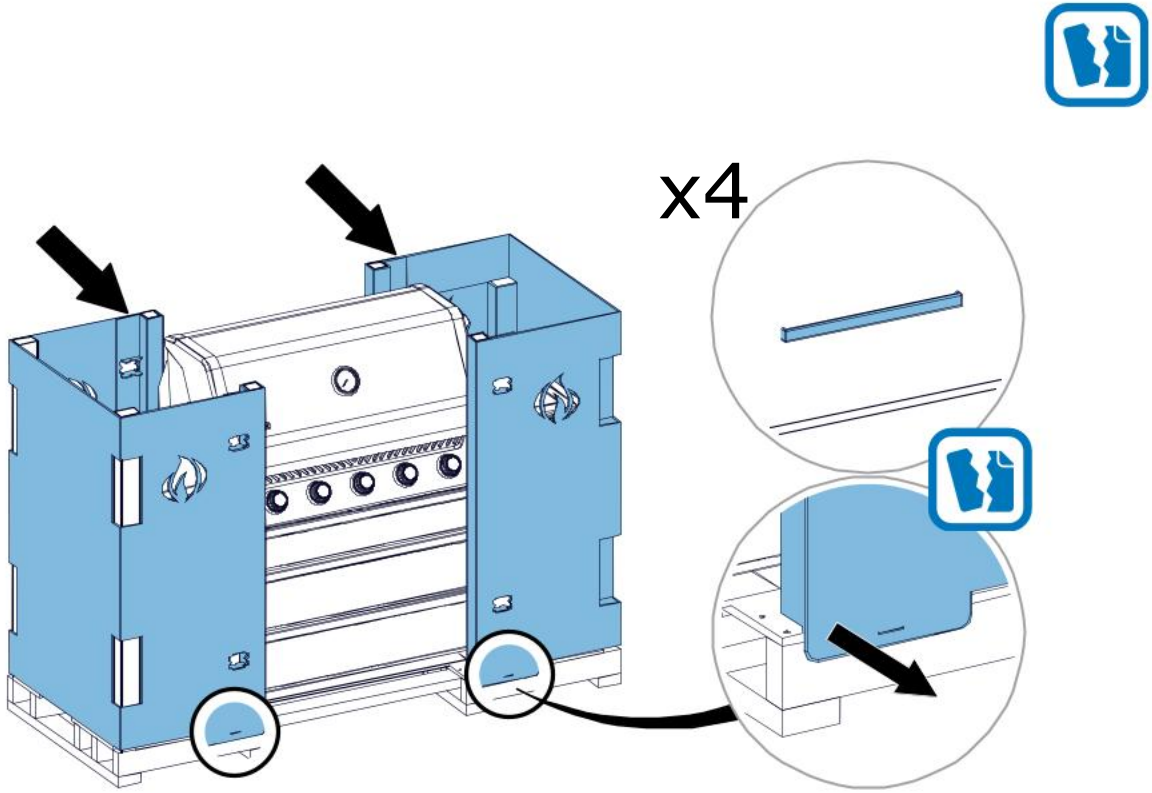

3

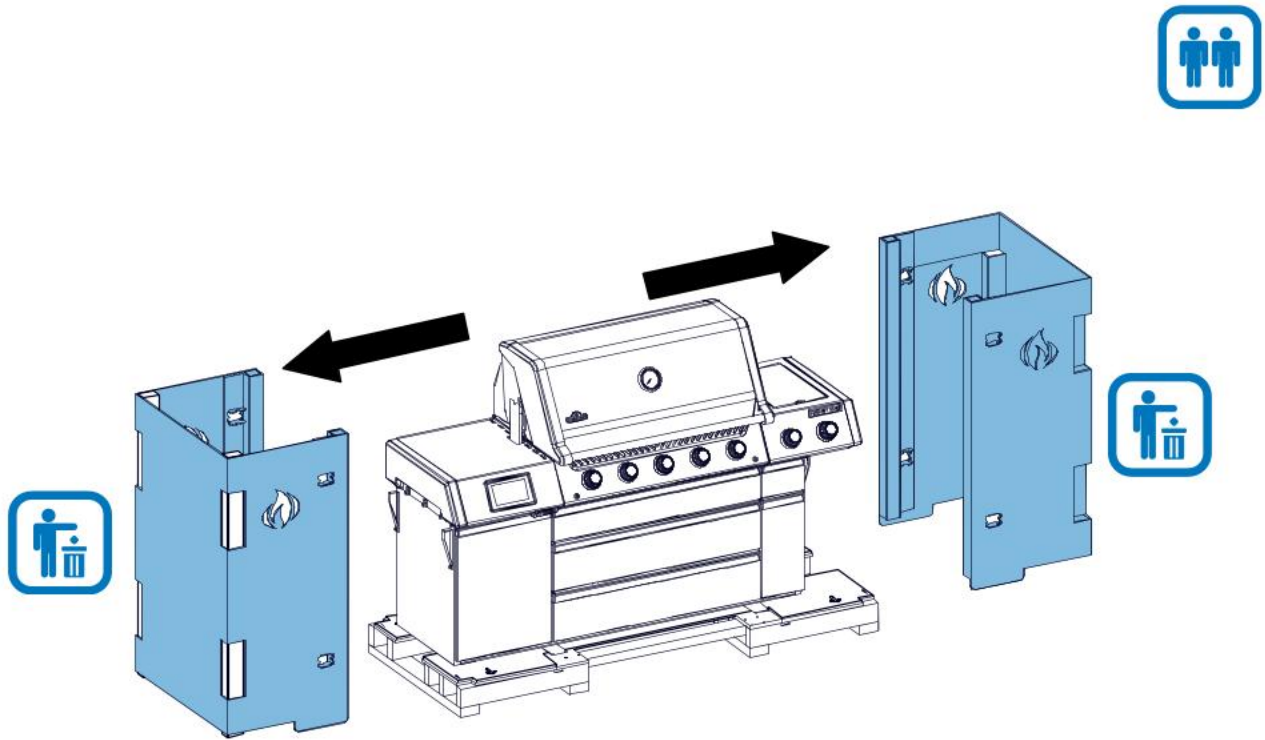

4

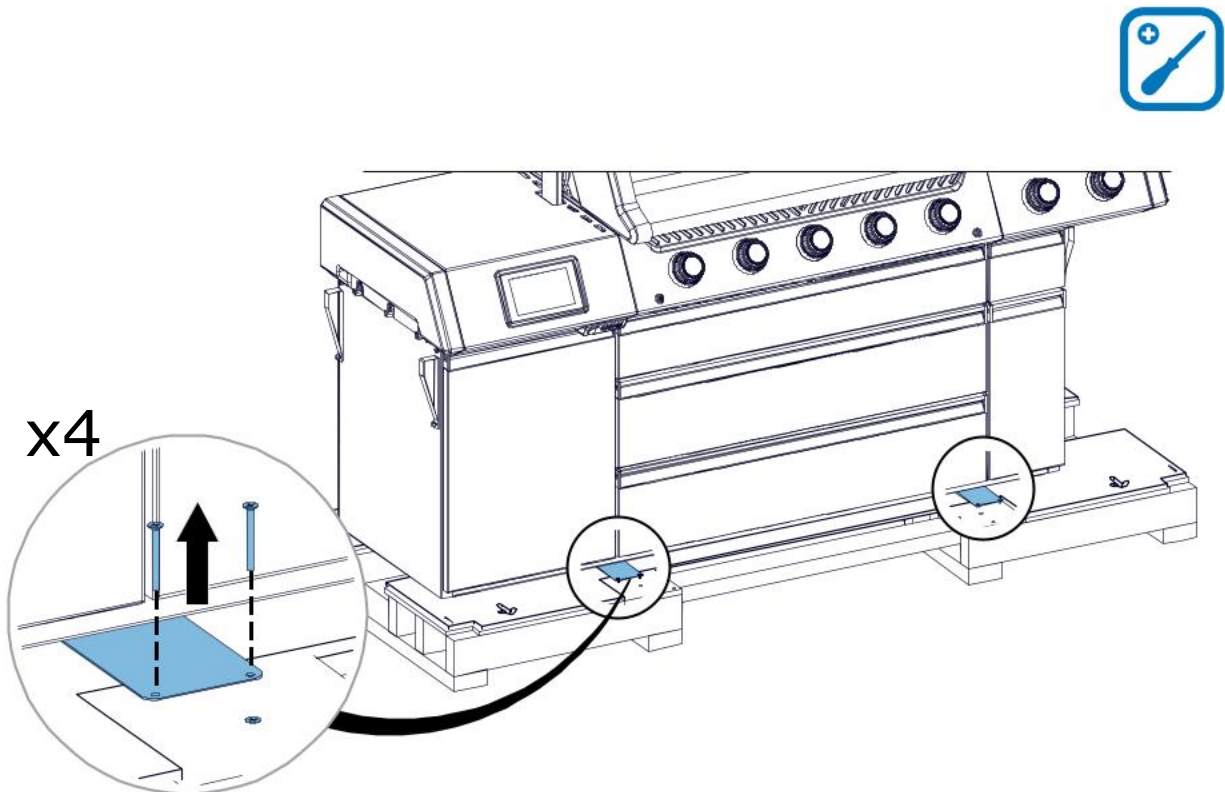

5

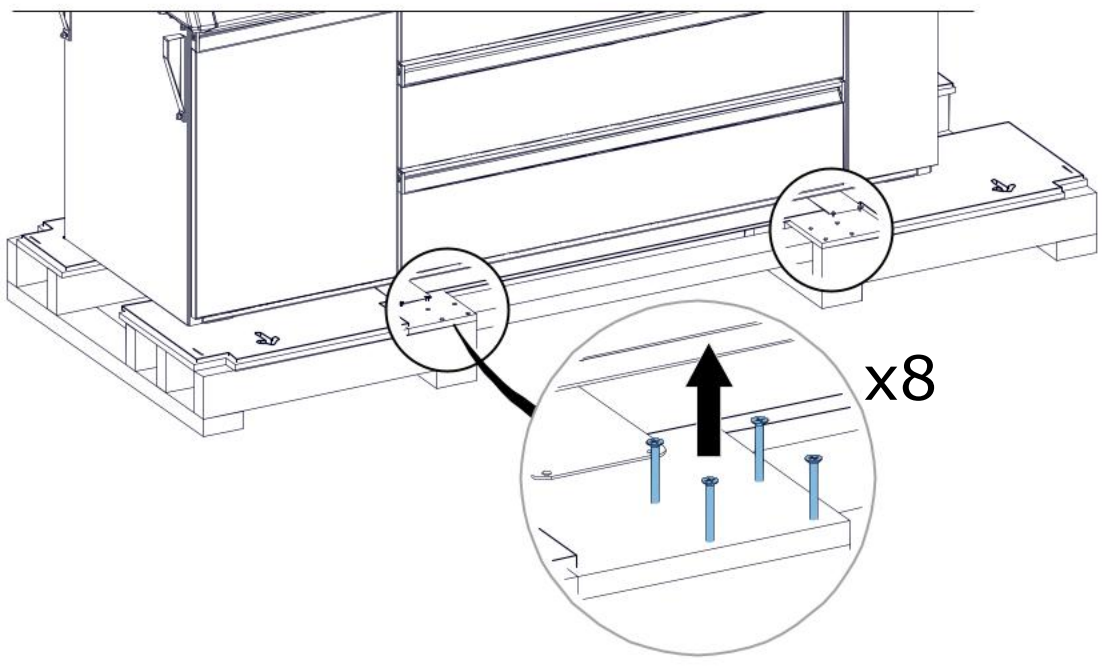

6

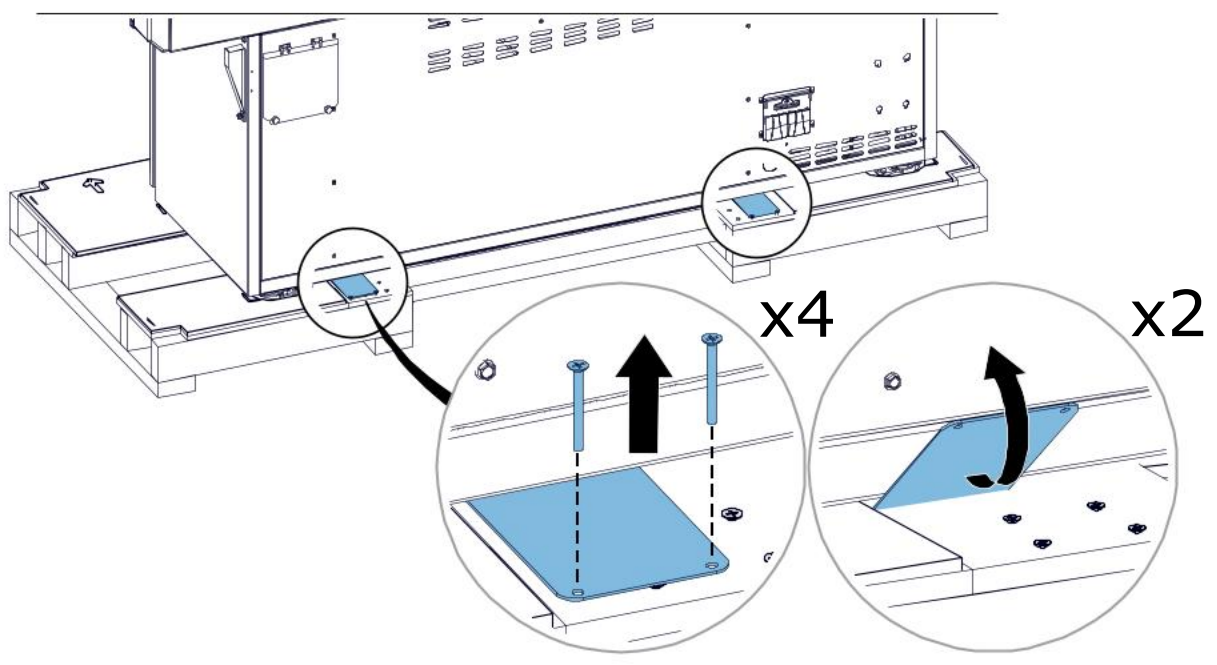

7

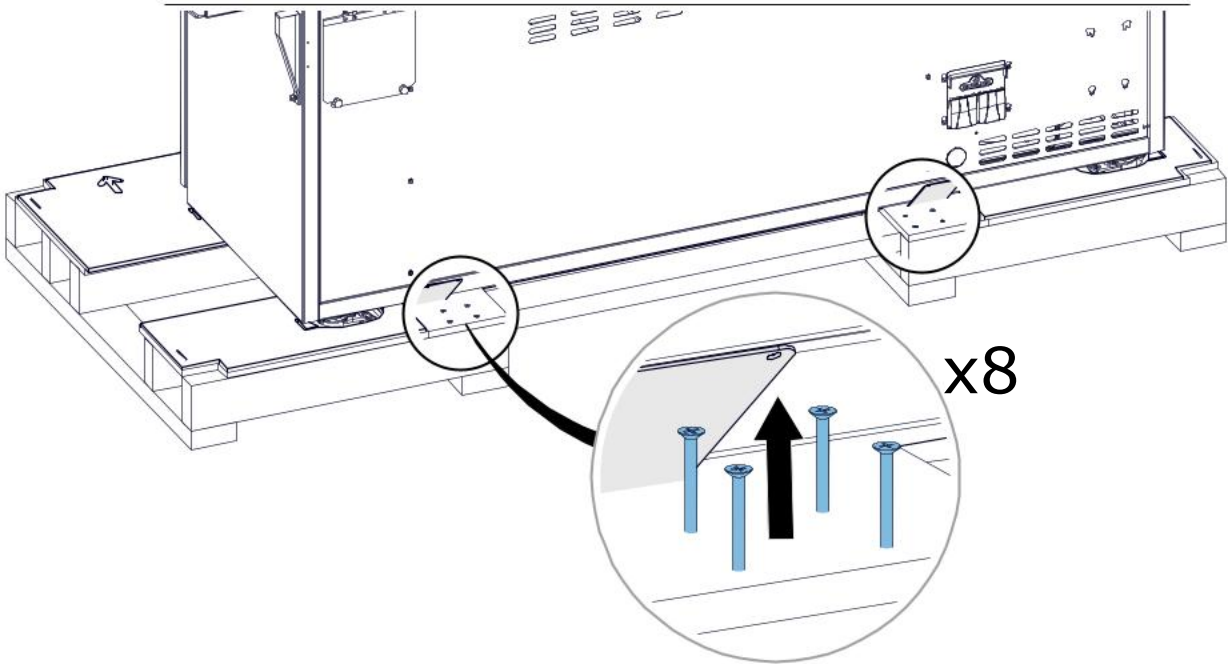

8

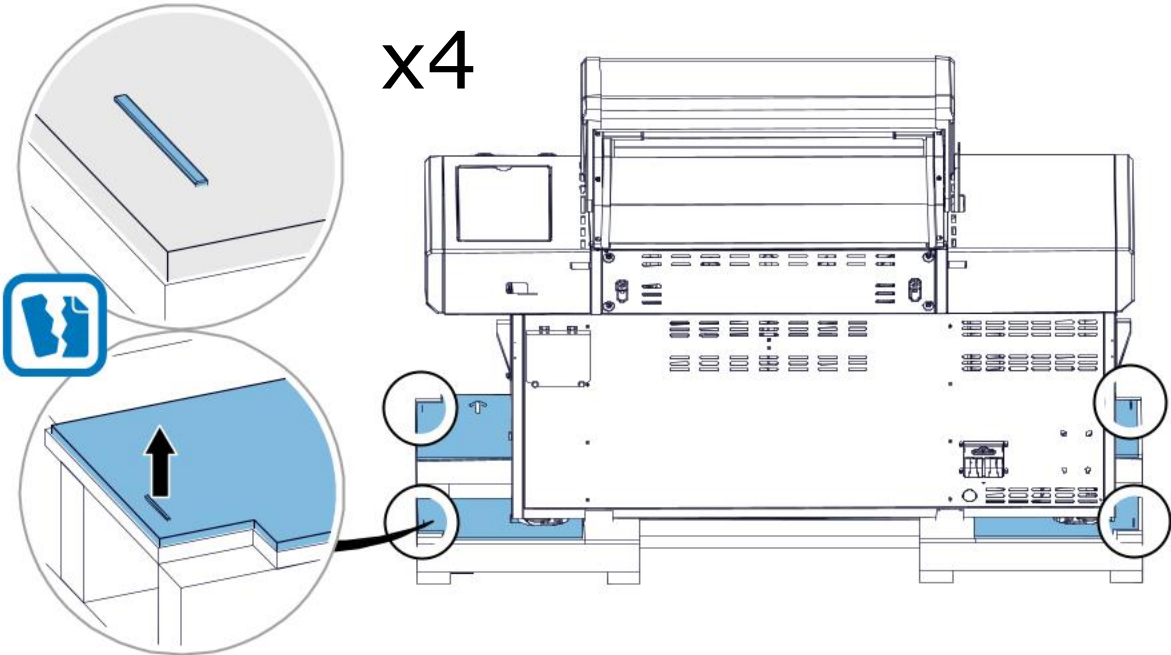

9

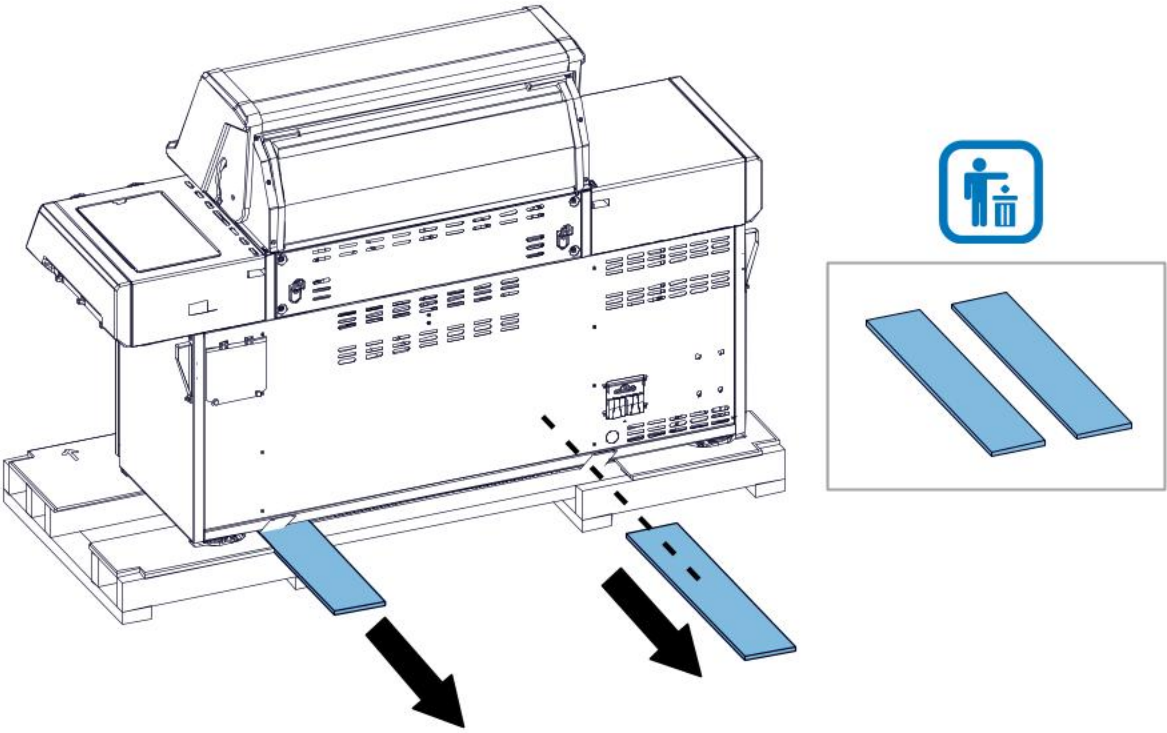

10

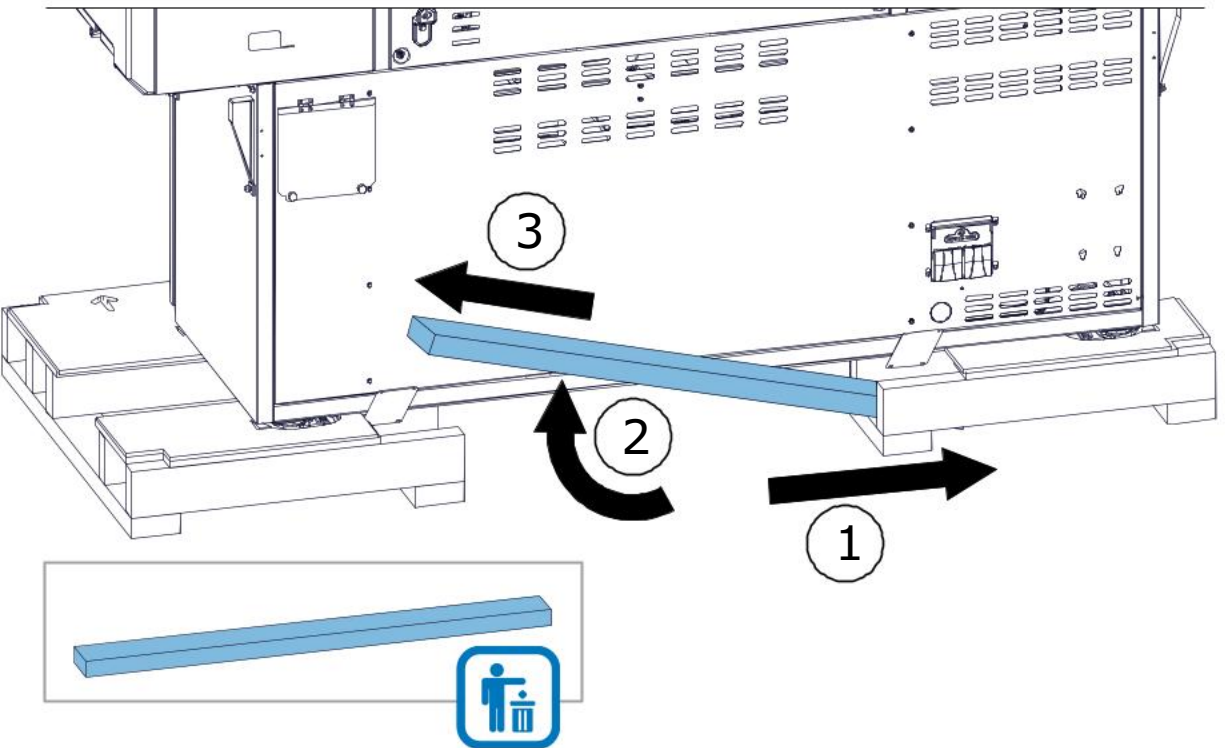

11

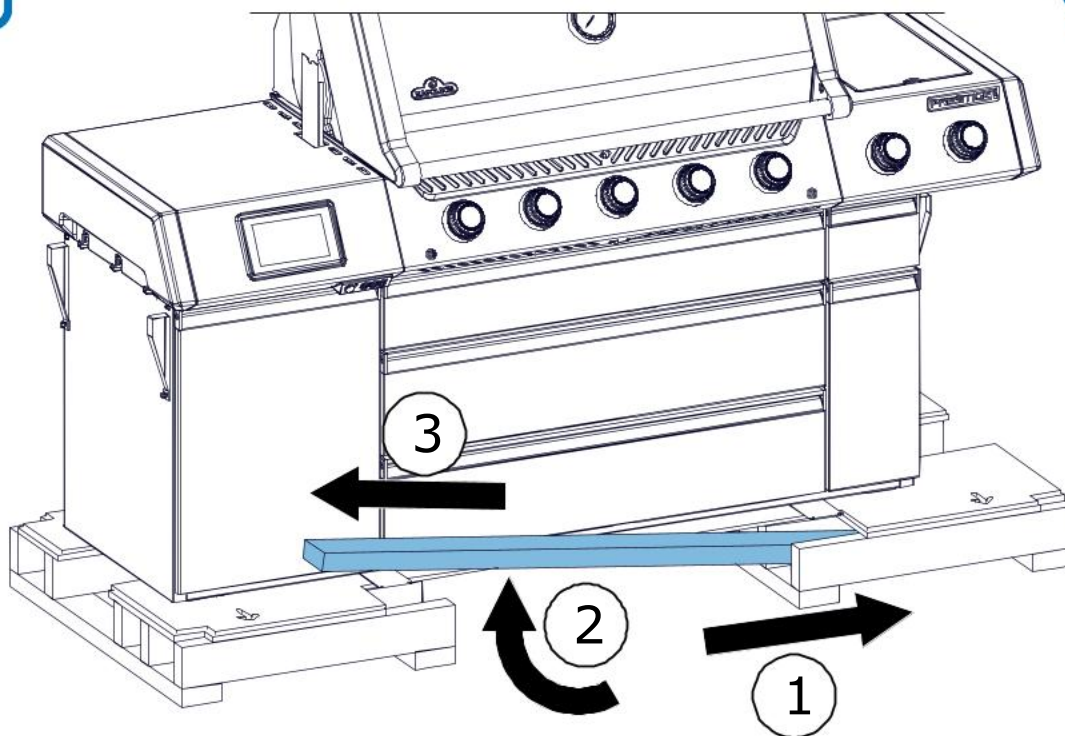

12

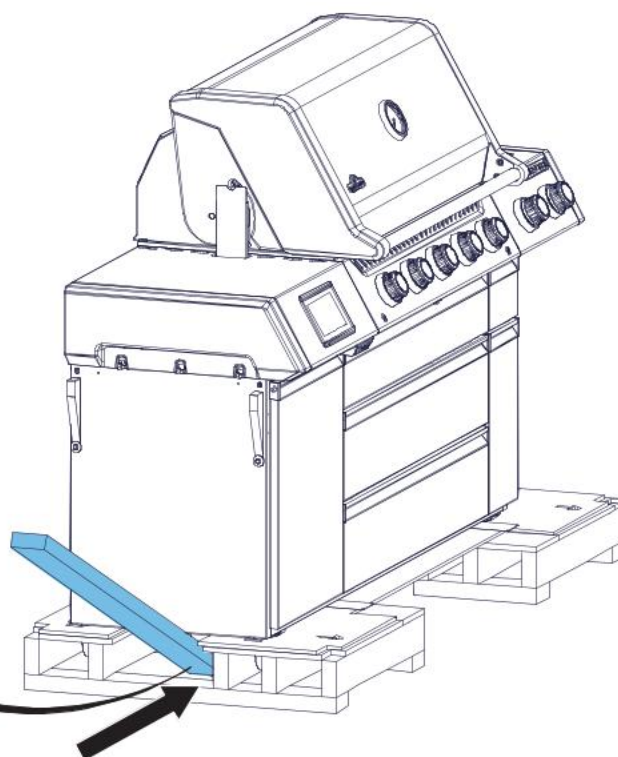
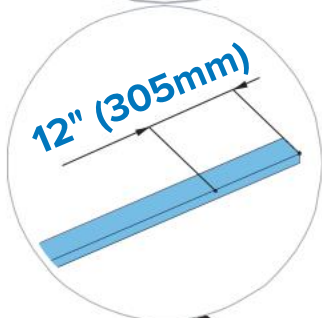
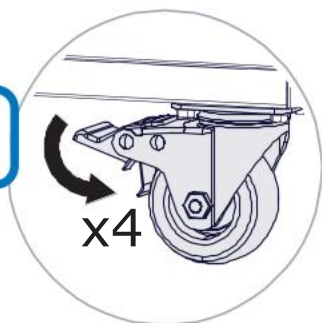

13

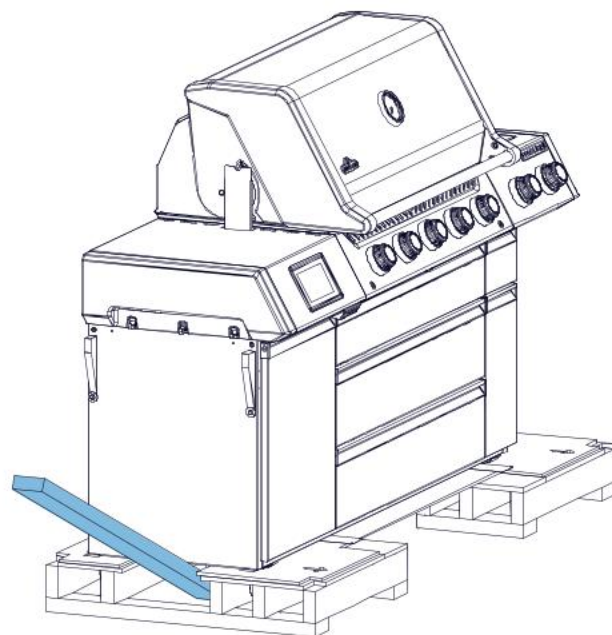
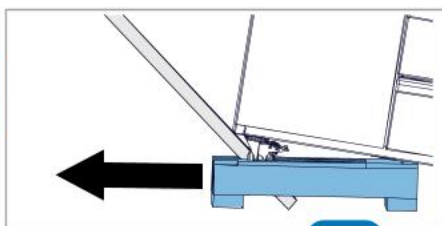
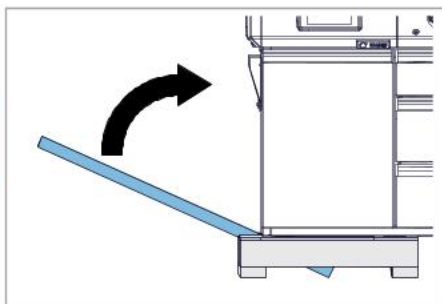

14

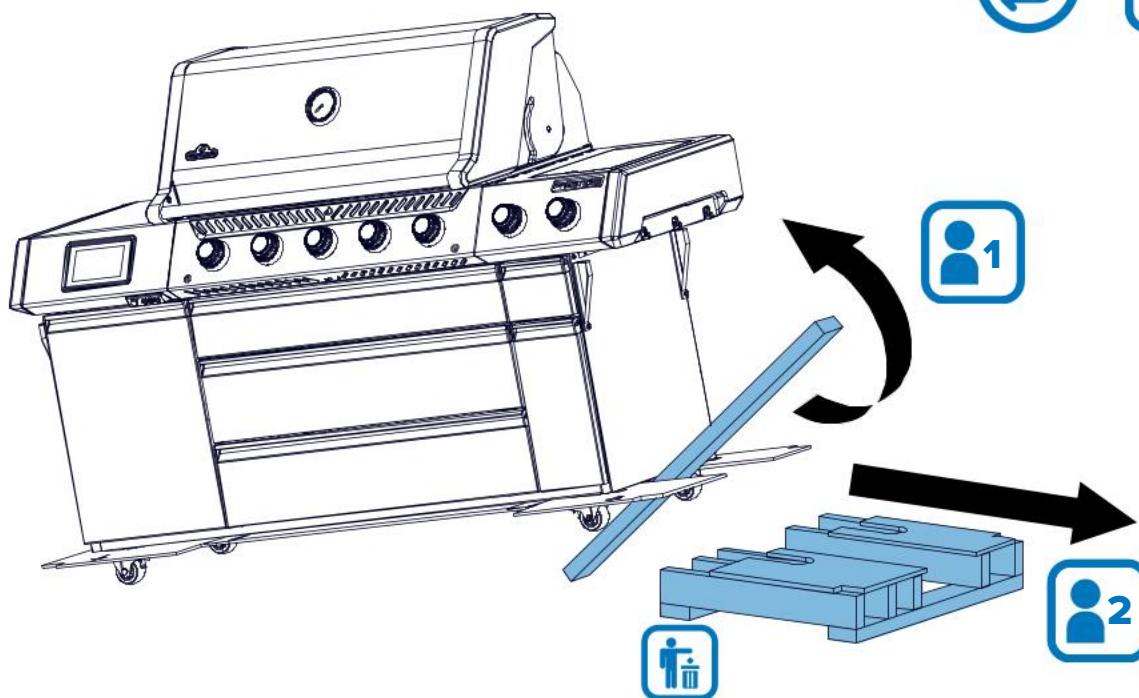

15

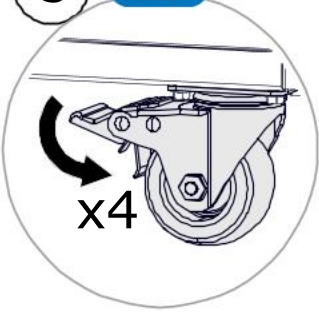
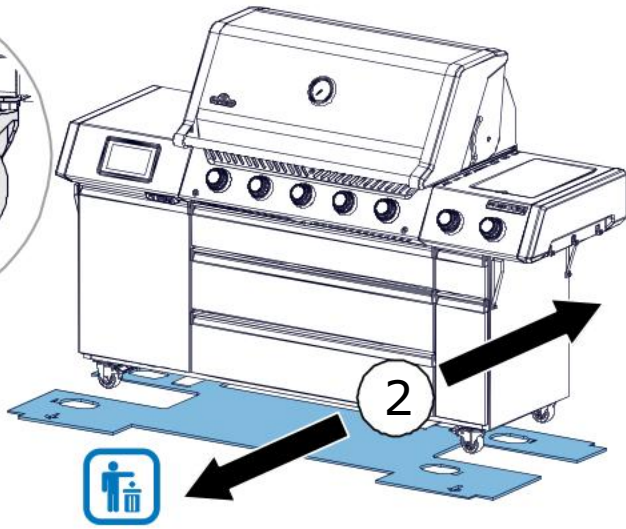
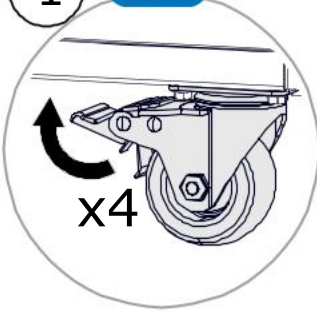

16

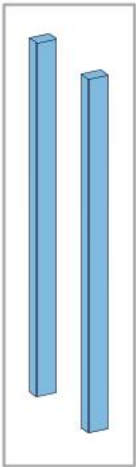

(2x3)x2

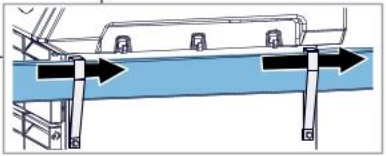
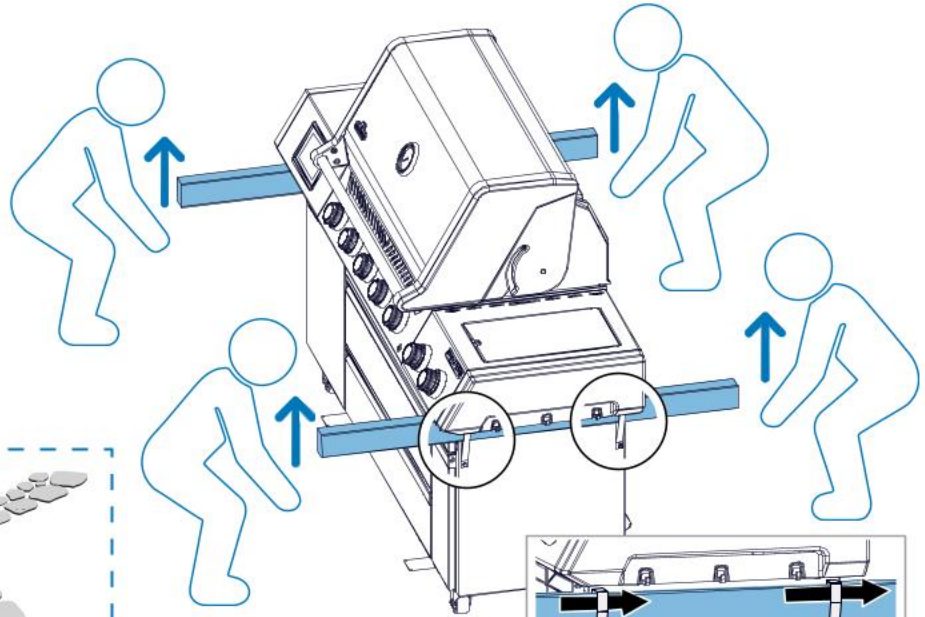
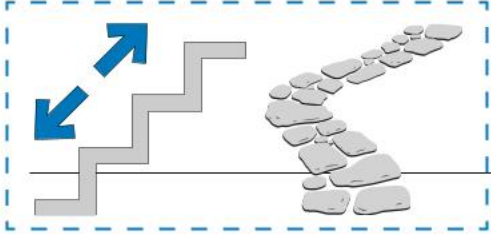

17

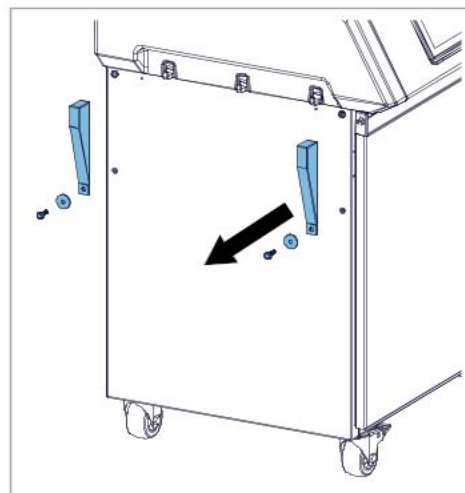
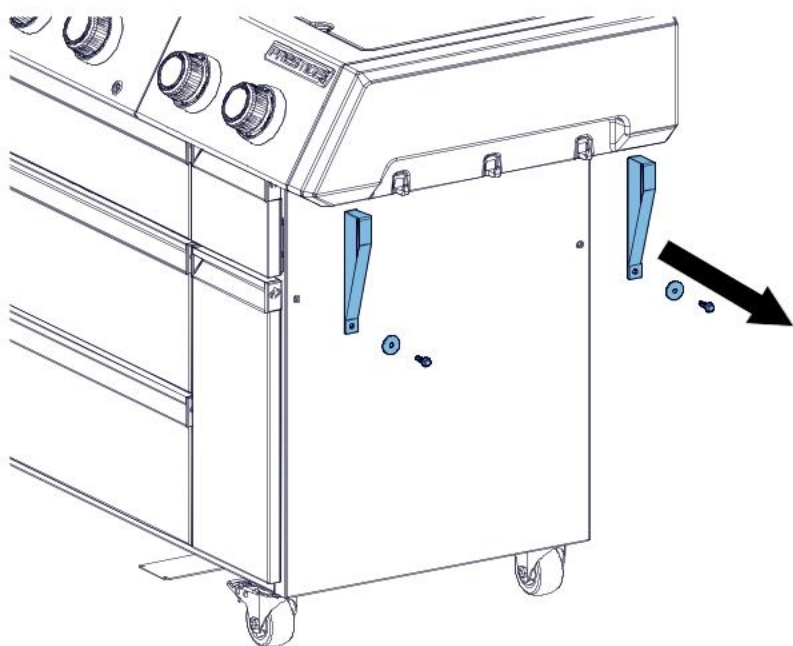

18

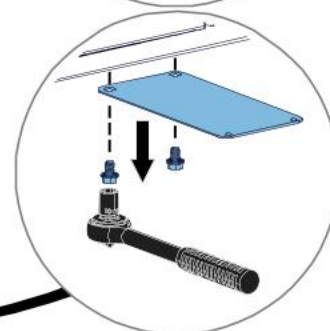
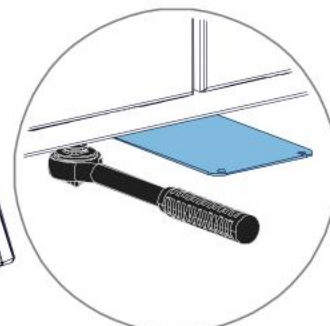
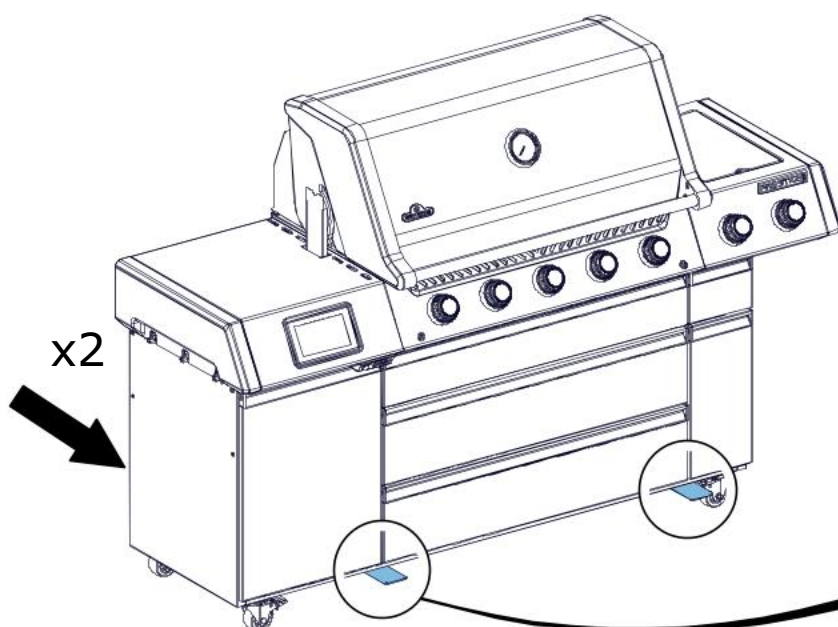

19

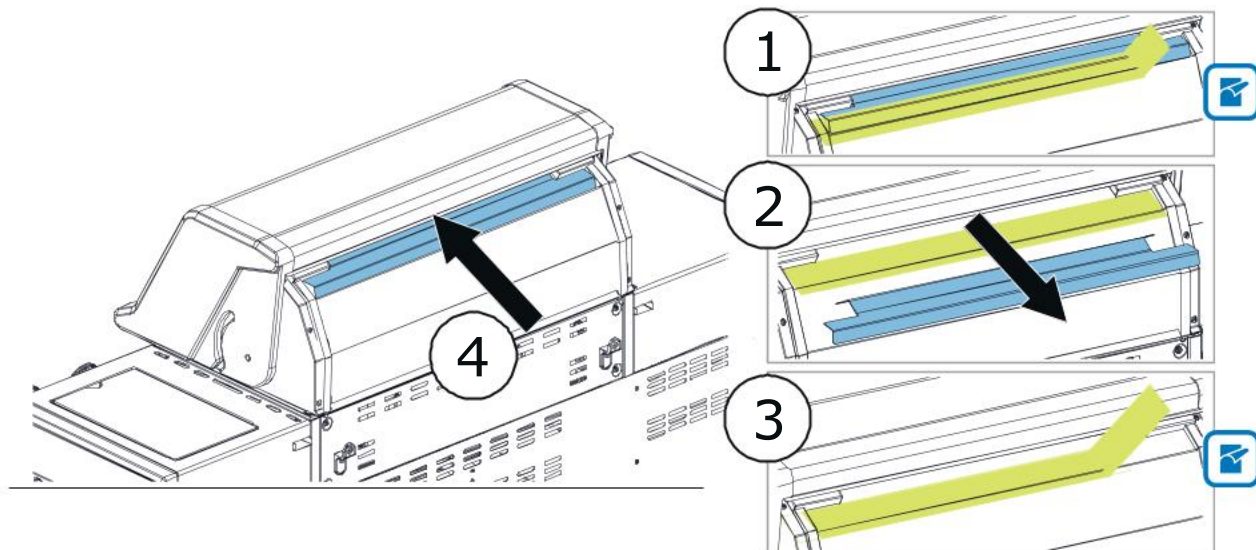

20

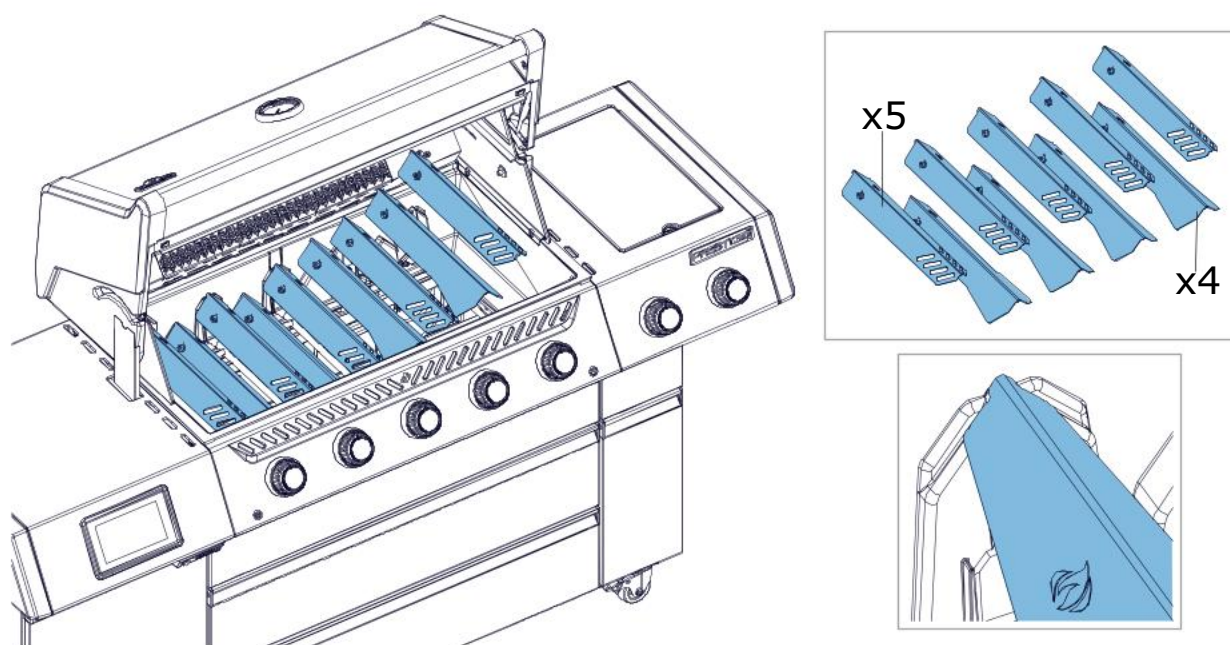

21

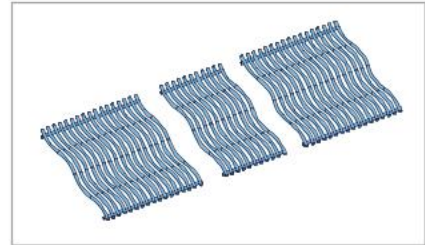
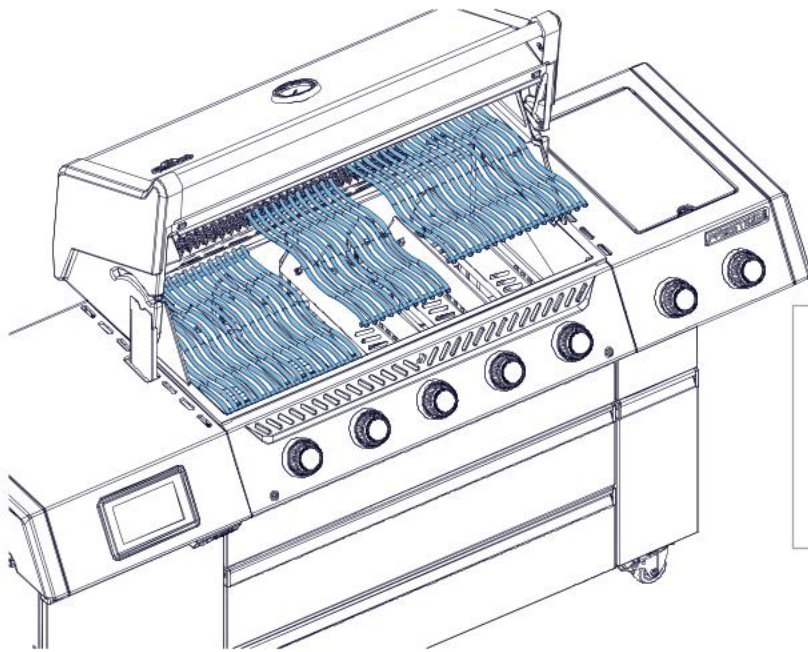

22

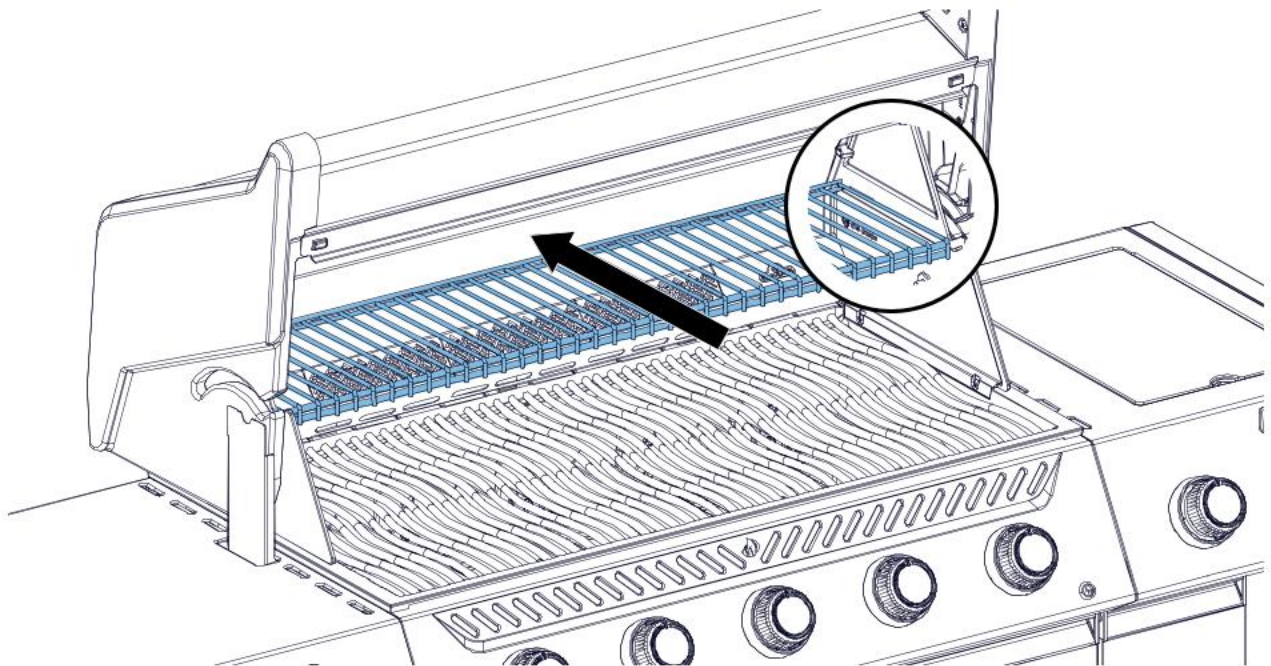
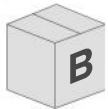

23

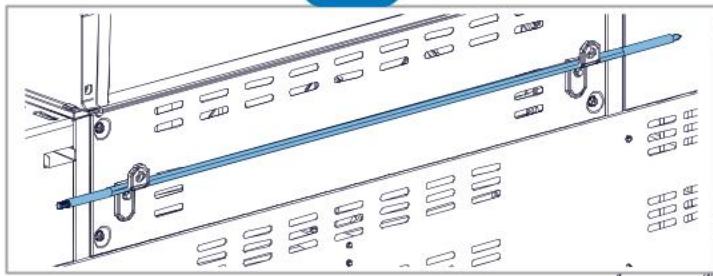

1

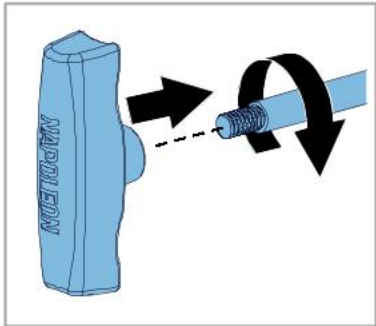

2

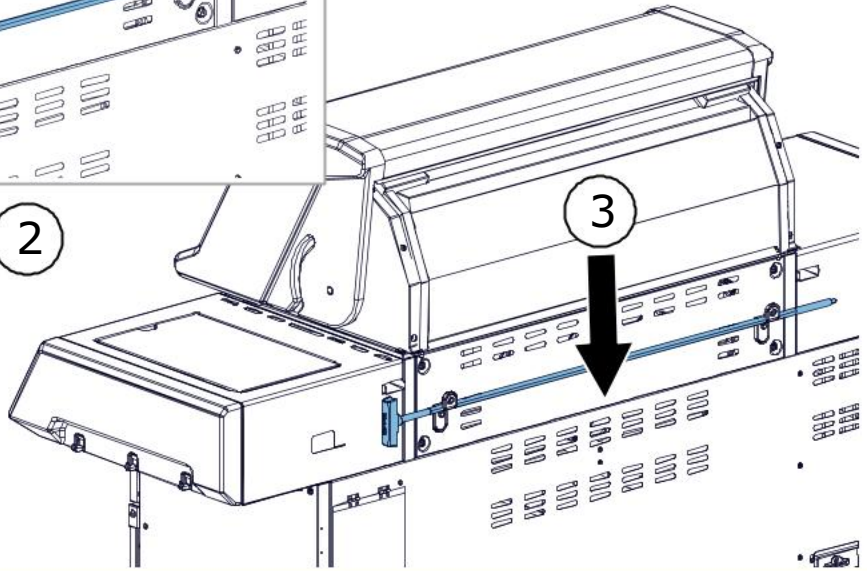

3

24

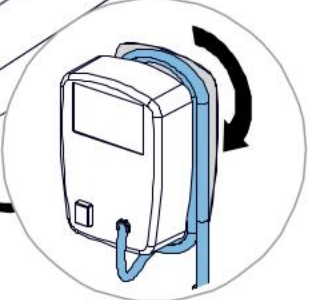
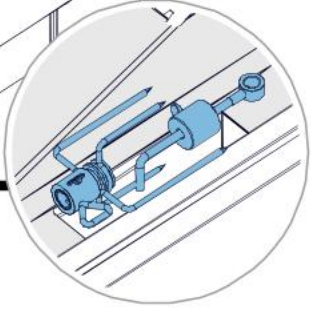
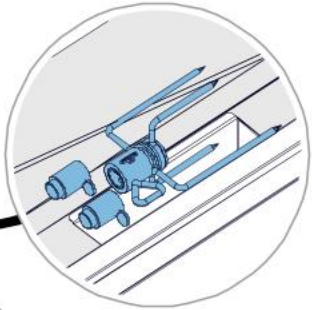
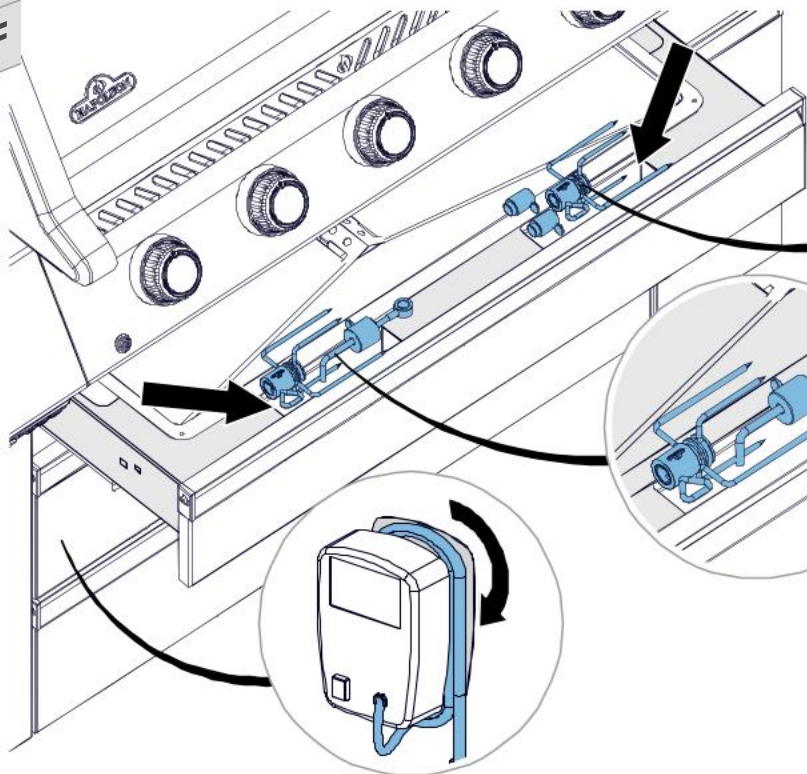

25

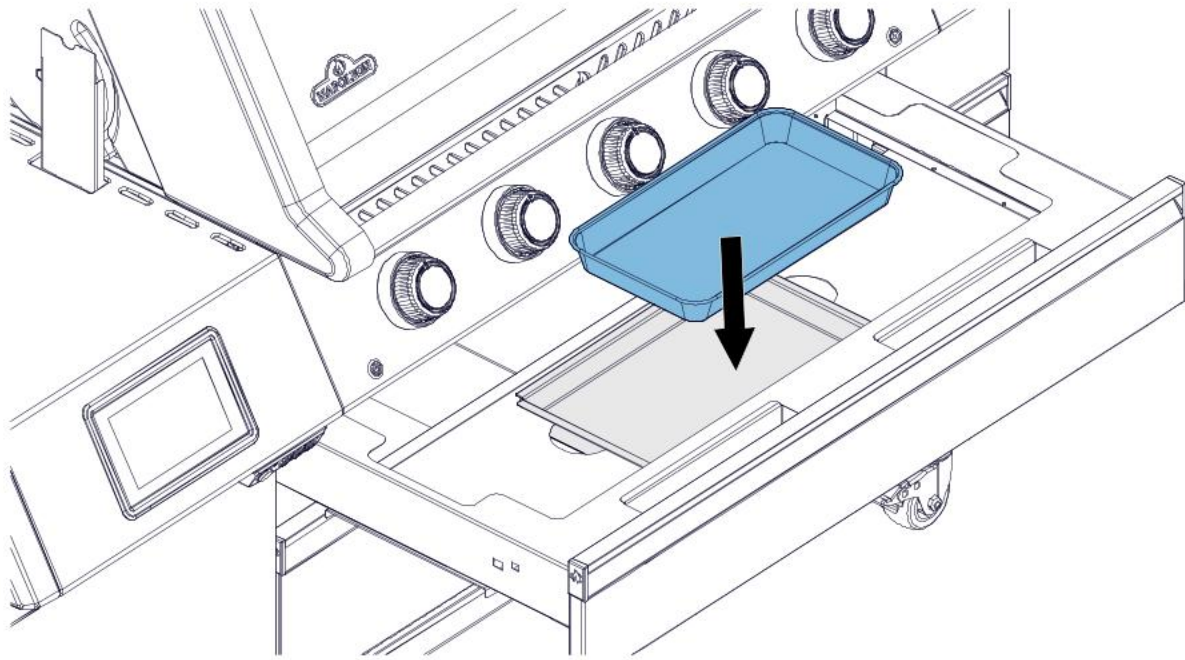
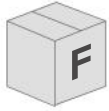

26

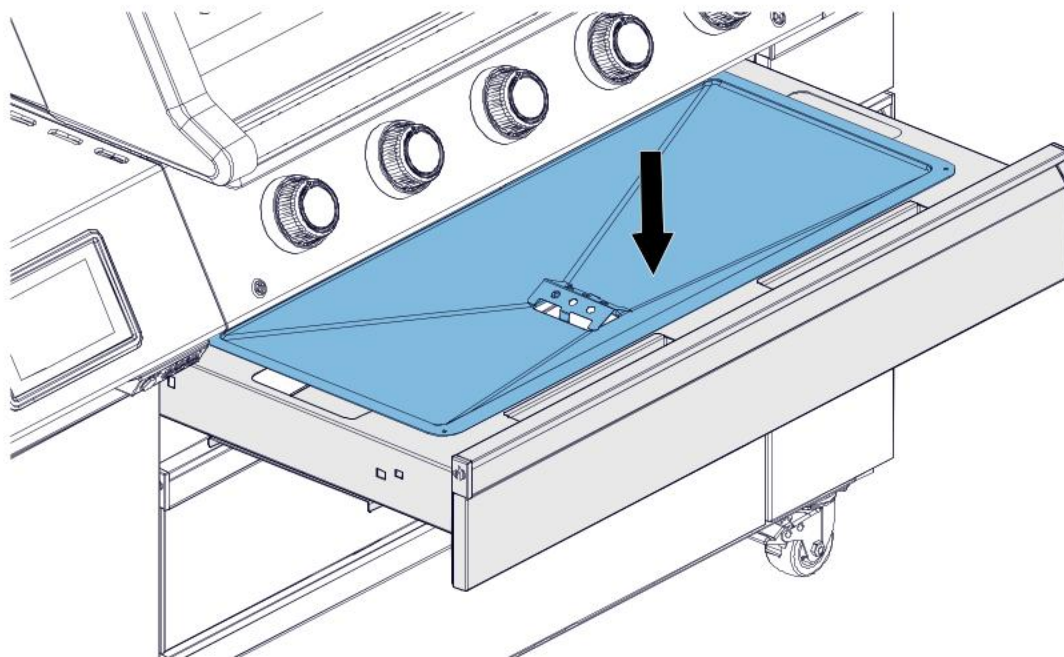
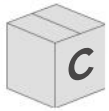

27

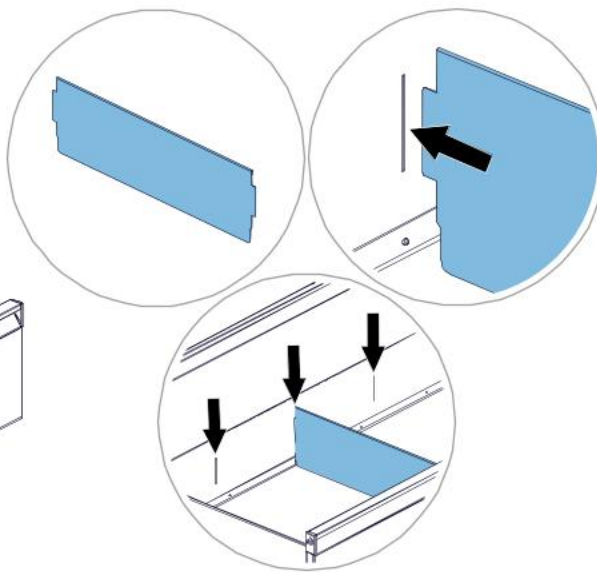
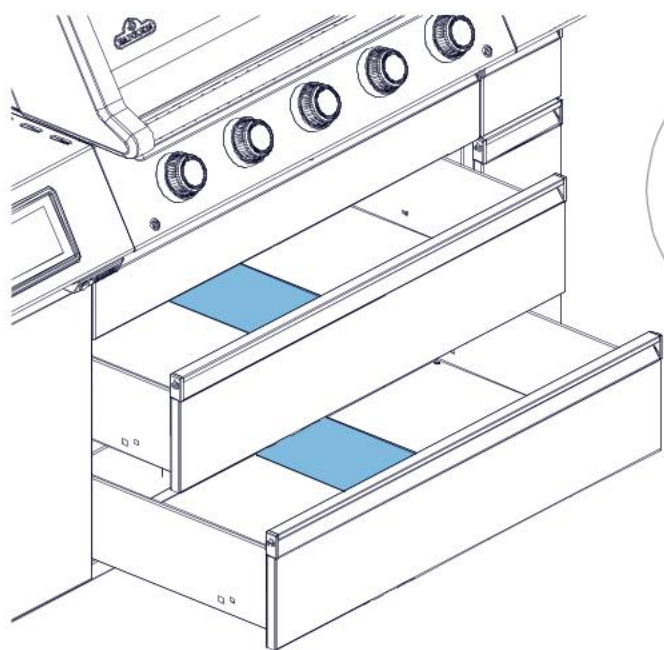

28

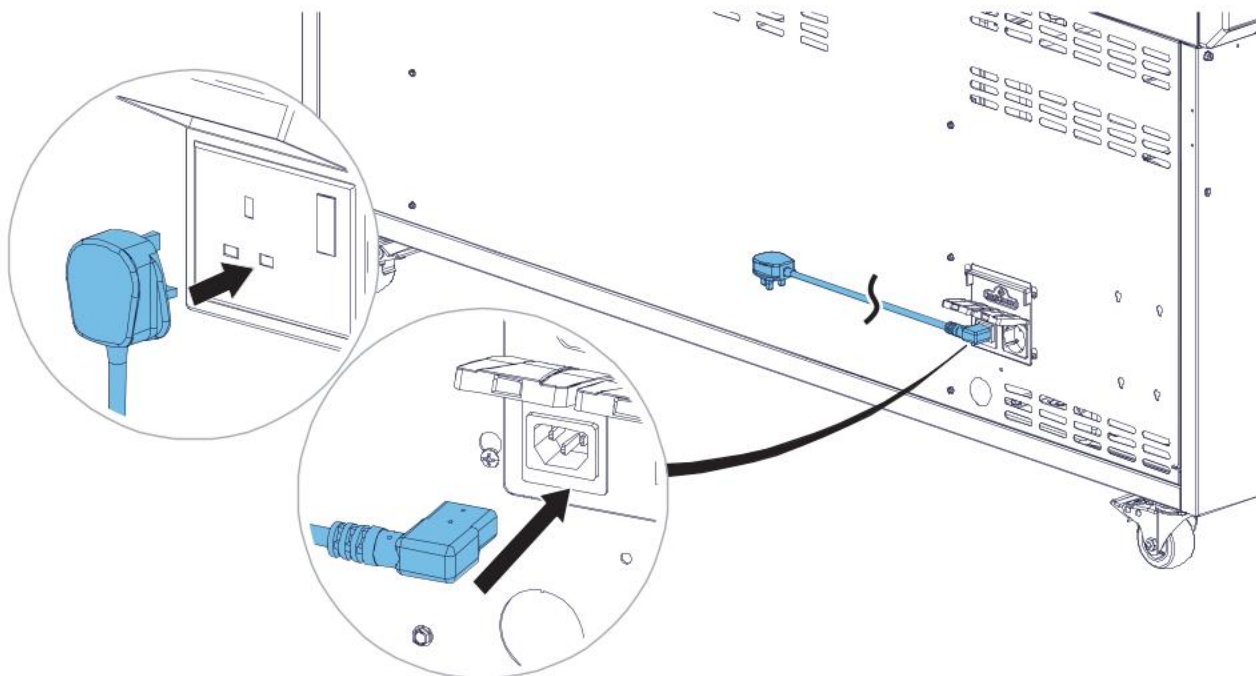

29

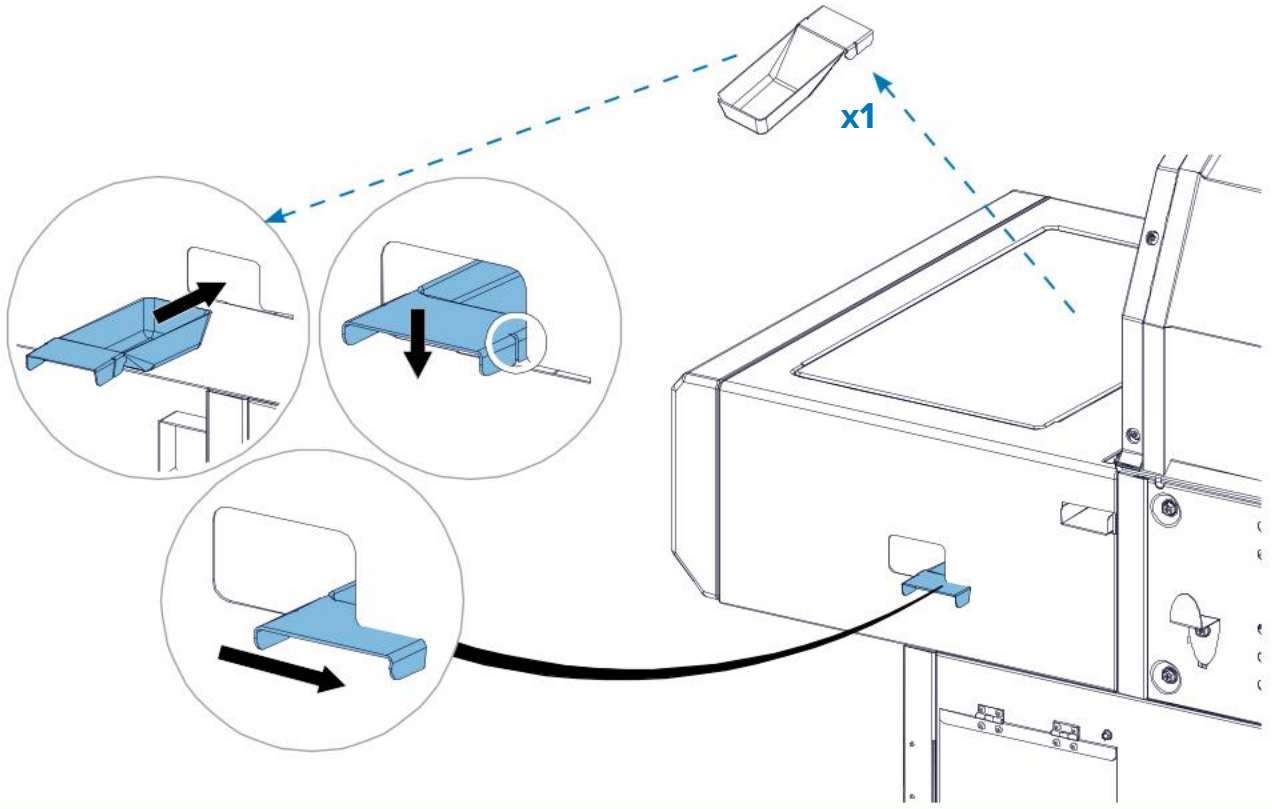

30

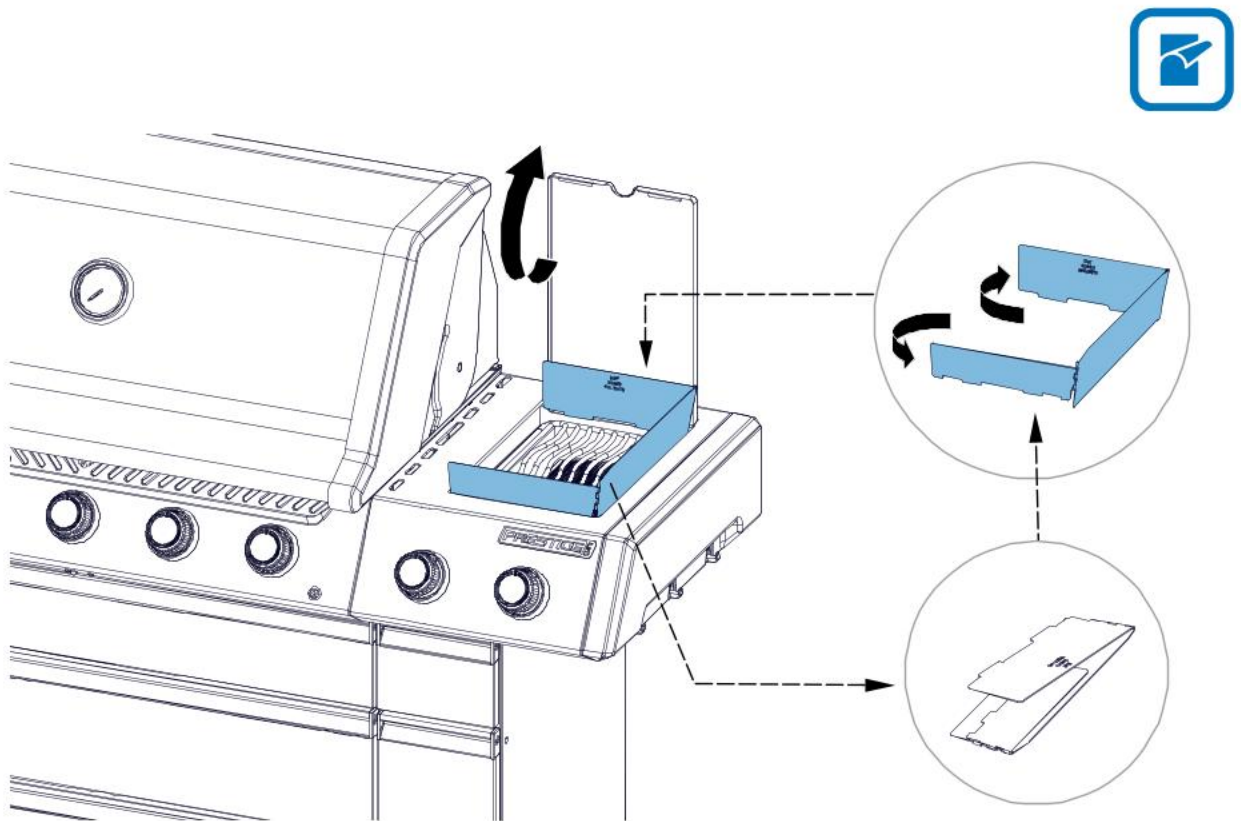

31

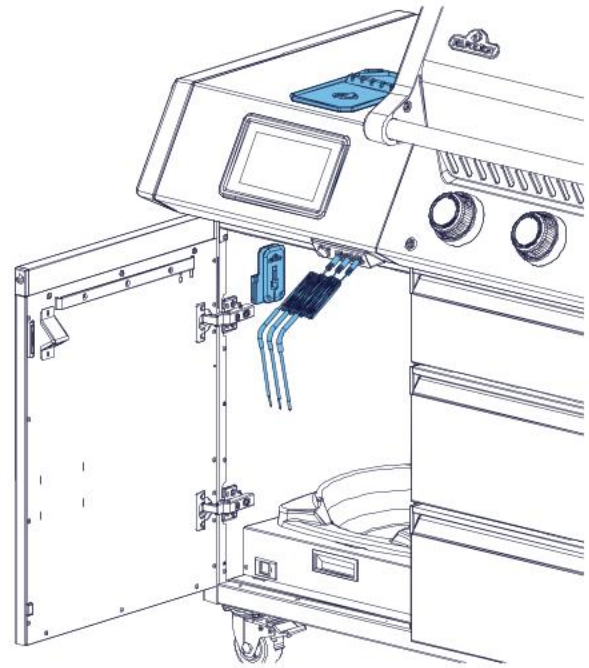
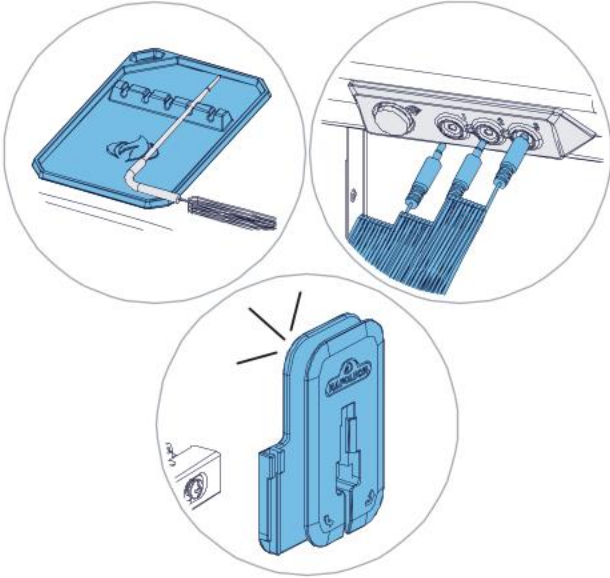

32

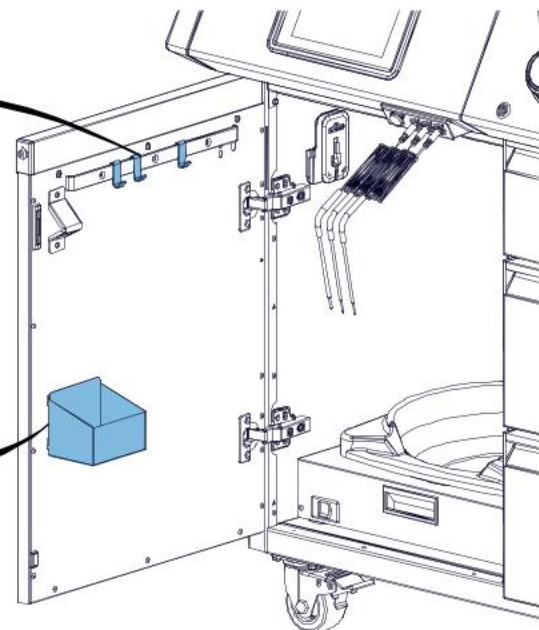
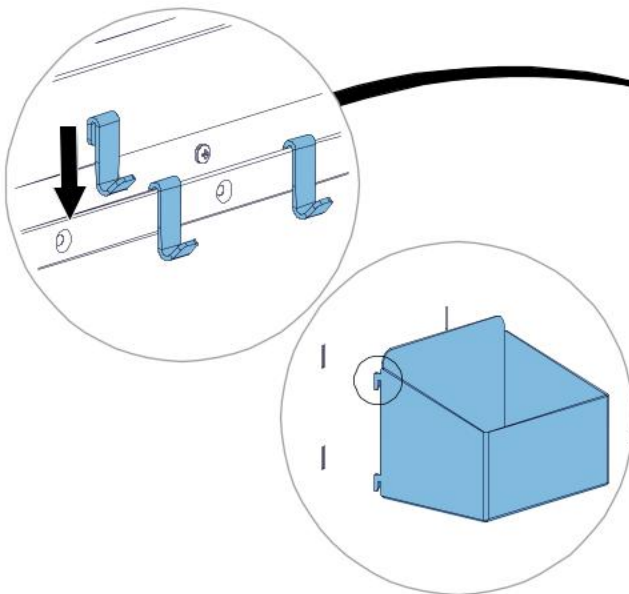

33

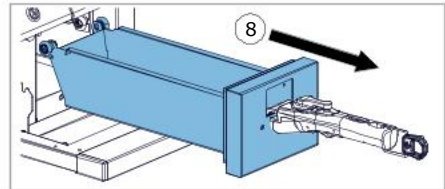
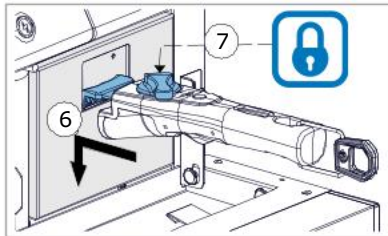
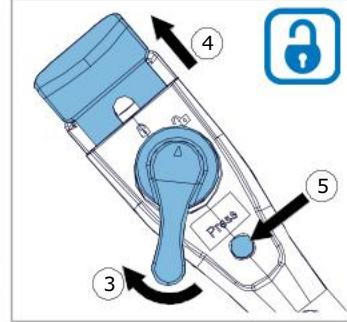
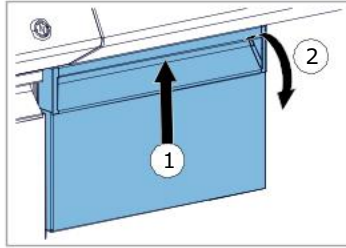
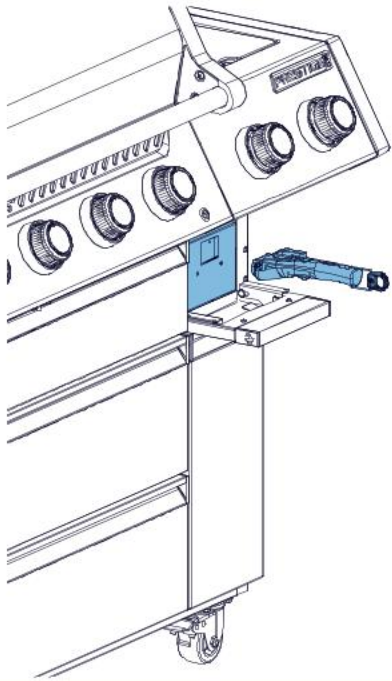

34

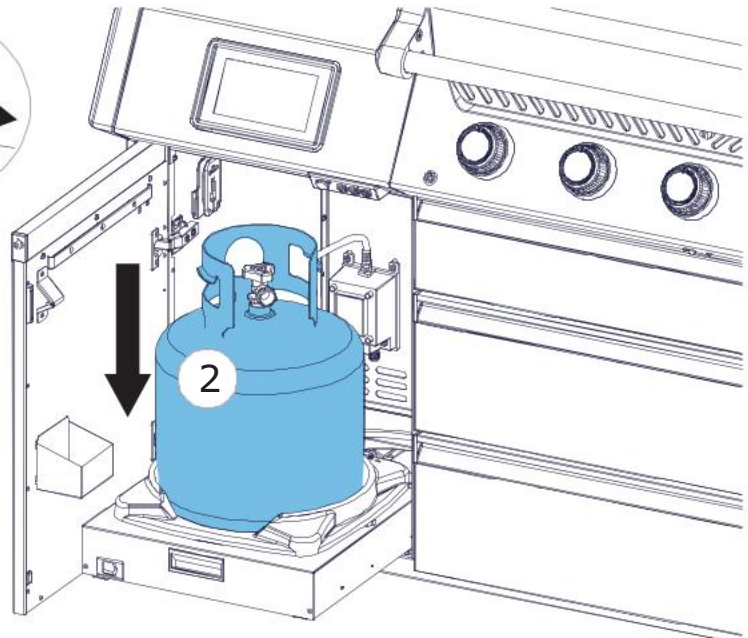
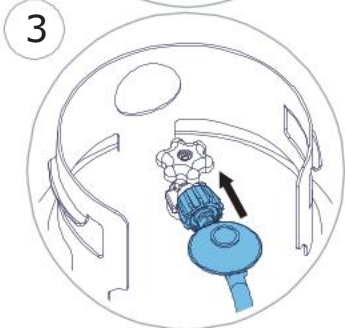
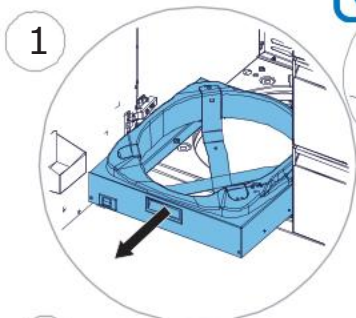

35

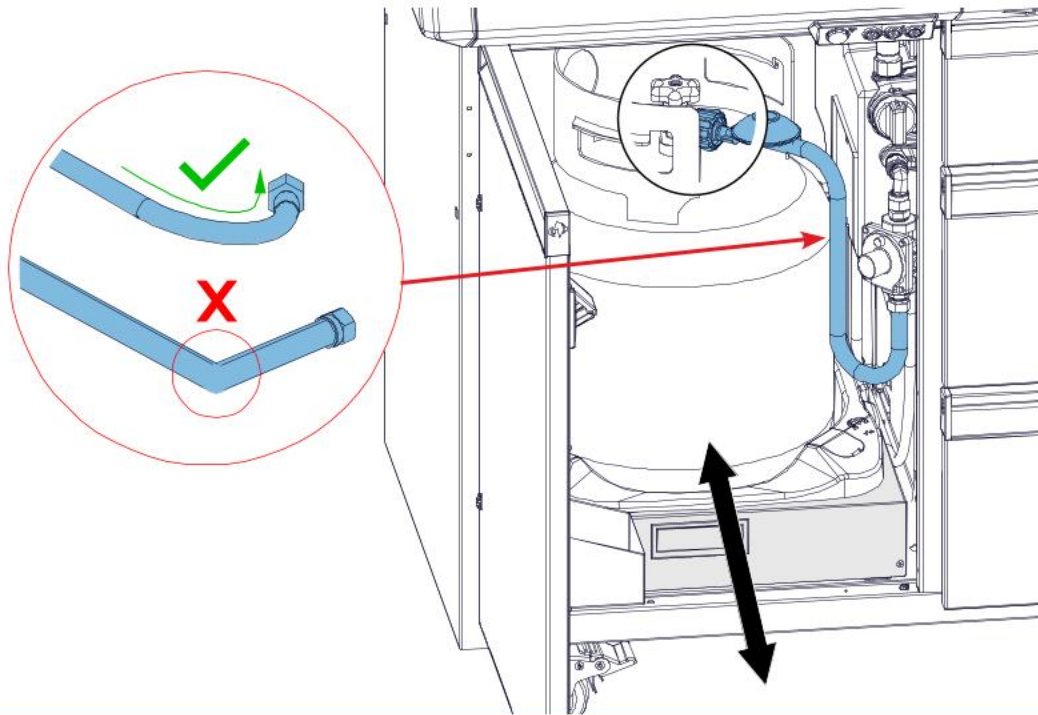

36



- SD cards with additional languages are available.
- Des cartes SD avec des langues supplémentaires sont disponibles.
- Hay disponibles tarjetas SD con idiomas adicionales.
- SD-Karten mit zusätzlichen Sprachen sind erhältlich.

- Insert SD card with unit OFF. Turn on to update. After update, remove card and restart grill.
- Insérez la carte SD lorsque l'appareil est éteint. Allumez-le pour effectuer la mise à jour. Une fois la mise à jour terminée, retirez la carte et redémarrez le grill.
- Inserte la tarjeta SD con la unidad apagada. Encienda la unidad para actualizar. Después de la actualización, retire la tarjeta y reinicie la parrilla.

- Setzen Sie die SD-Karte bei ausgeschaltetem Gerät ein. Schalten Sie das Gerät ein, um das Update durchzuführen.

Nach Abschluss des Updates die Karte entfernen und den Grill neu starten.

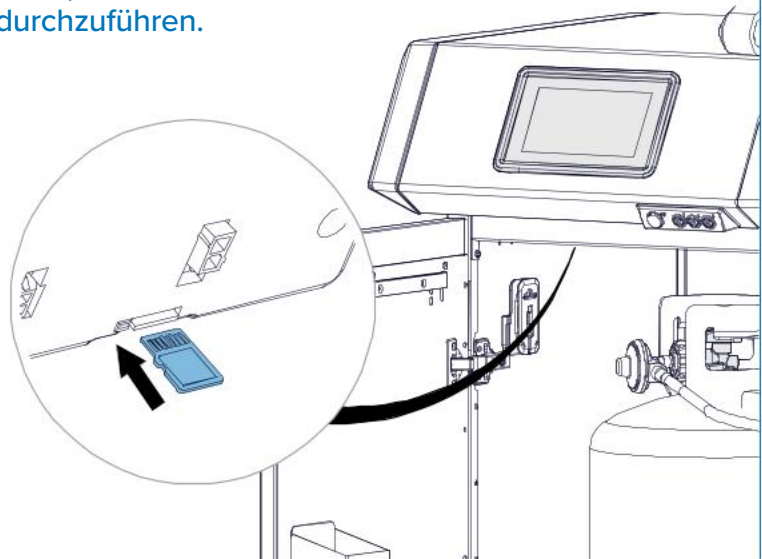

37

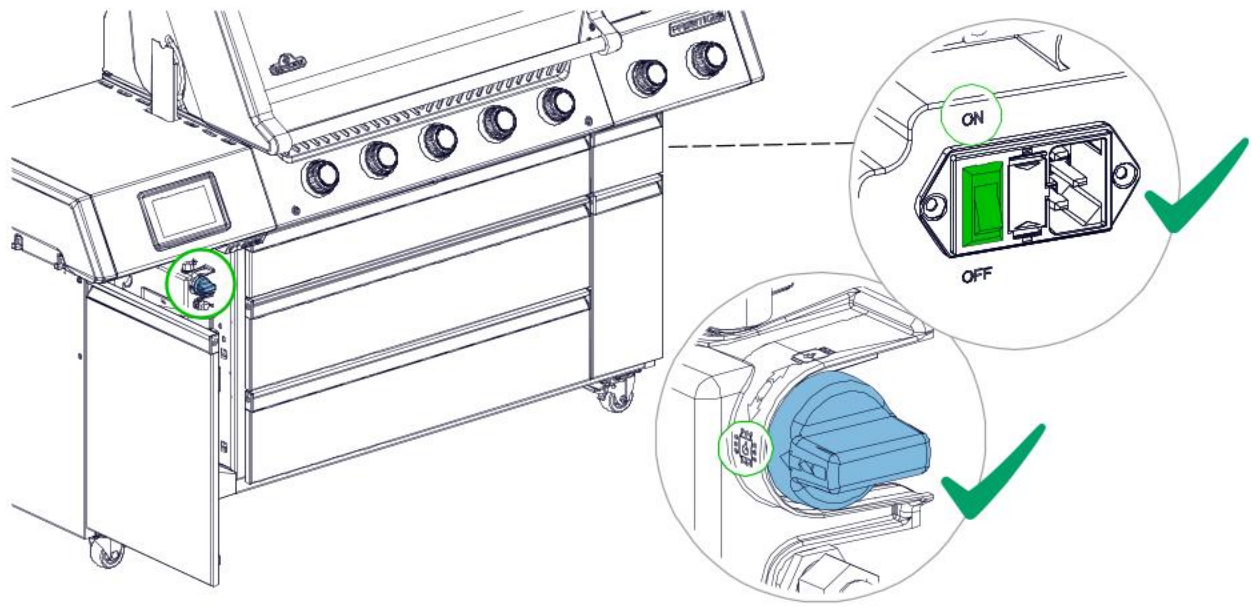

38

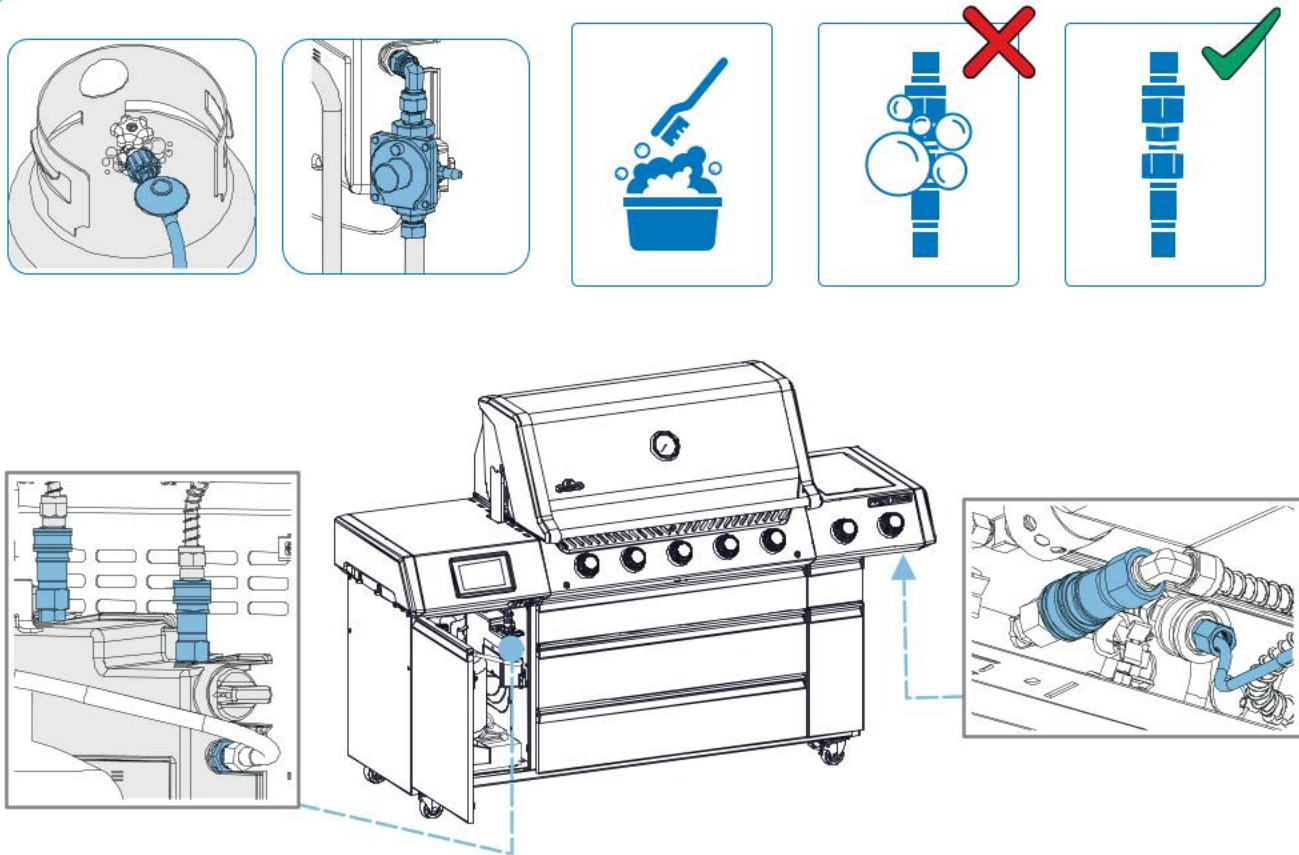

Parts List
Liste des pieces
Lista de piezas
Teileliste

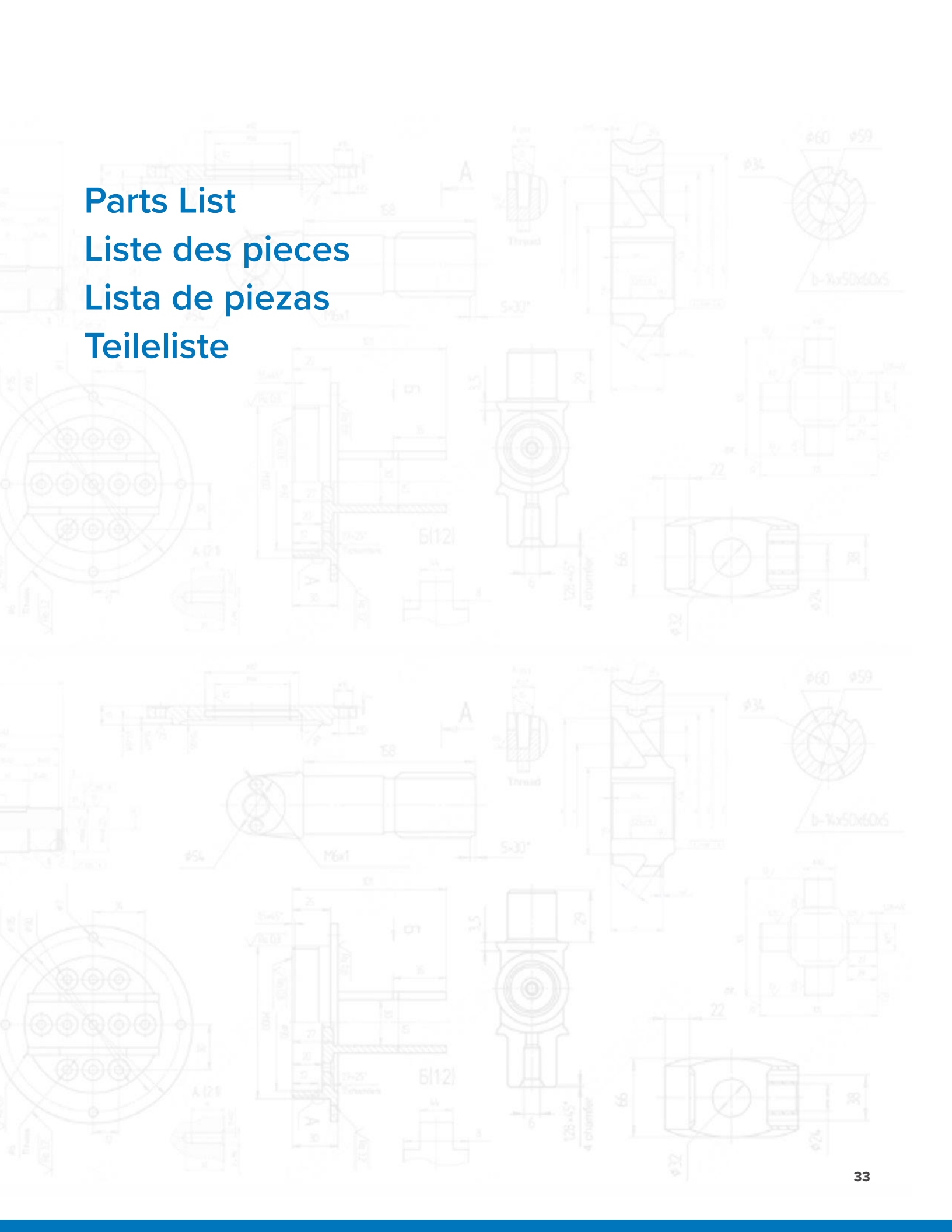

Grill Overview | Vue d'ensemble du gril
Visión general de la parrilla | Grill-Übersicht

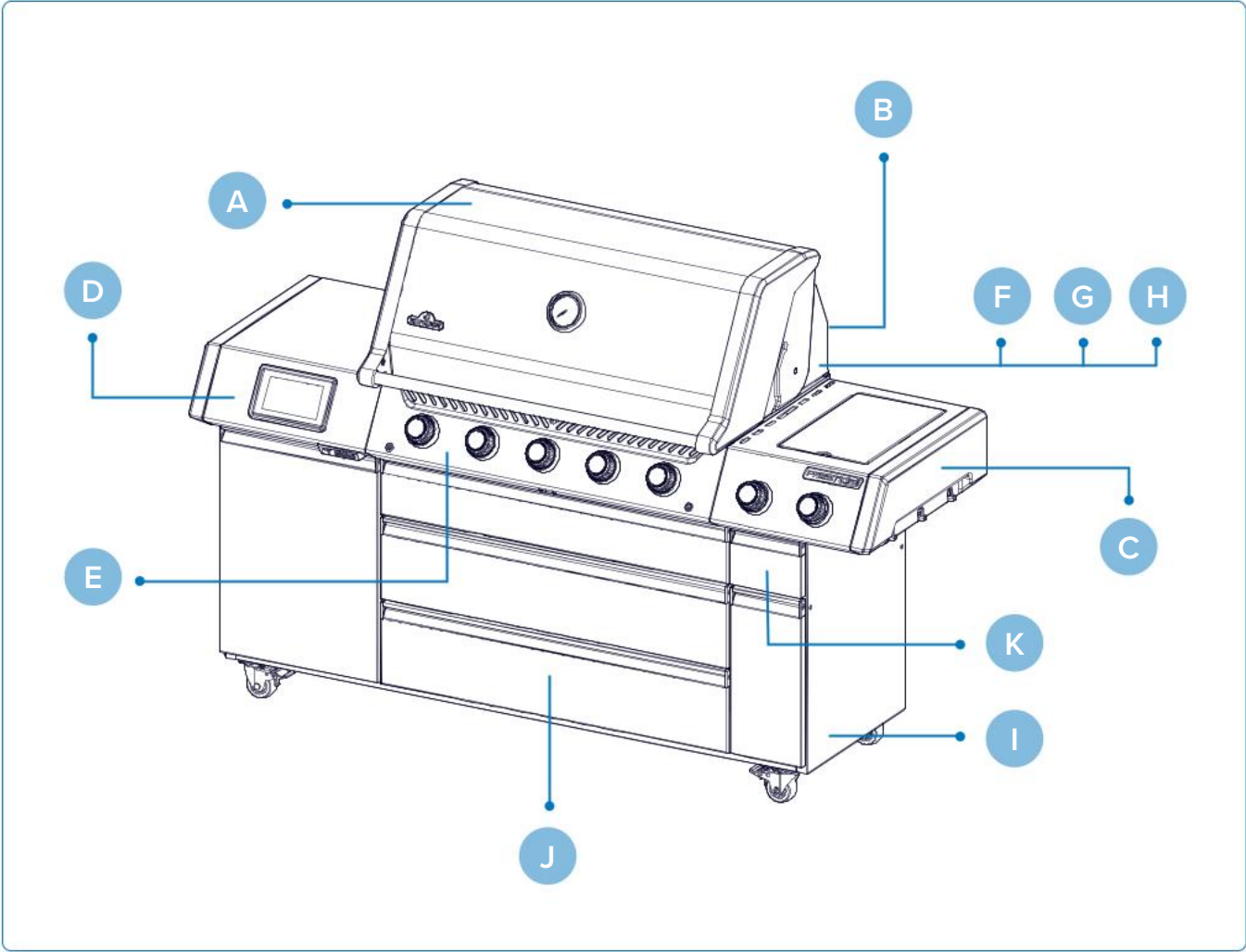

Lid | Couvercle | Tapa | Deckel

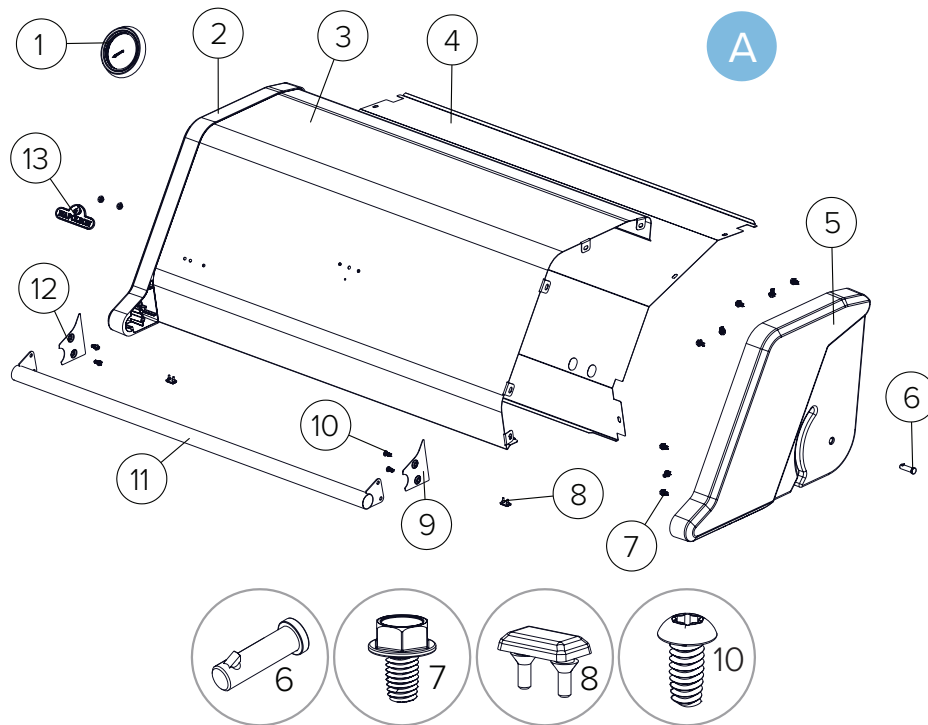

| | Part # Partie # Parte # Teil # | Description Description Descripción Beschreibung |
|----|--------------------------------|---|
| A | N010-1840-SS | Lid Assembly Ensemble couvercle Ensamblaje de la tapa Deckelbaugruppe |
| 1 | N010-1831 | Temp. Gauge Bezel Cadran de la jauge de température Bisel del indicador de temperatura Temperaturanzeige-Blende |
| 2 | N135-10002703-GY1HT | Lid Casting Left Pièce moulée du couvercle gauche Fundición de tapa, izquierda Temperaturanzeige-Blende |
| 3 | N360-10002693 | Lid Insert Insert du couvercle Inserto de tapa Deckel-Einsatz |
| 4 | N585-10003332 | Lid Heat Shield Bouclier thermique du couvercle Protector térmico de la tapa Deckel-Hitzeschild |
| 5 | N135-10002704-GY1HT | Right Lid Casting Couvercle moulé droit Fundición de la tapa derecha Rechter Deckelguss |
| 6 | N485-0033 | Clevis Locking Pin Goupille de verrouillage à chape Pasador de bloqueo de horquilla Gabelkopf-Sicherungsstift |
| 7 | N570-0122 | Lid Assembly Screw Vis d'assemblage du couvercle Tornillo del conjunto de la tapa Deckel-Montageschraube |
| 8 | N510-0013 | Silicone Bumper Pare-chocs en silicone Parachoques de silicona Silikon-Stoßfänger |
| 9 | N200-10002700-GY1HT | Right Lid Handle Cover Cache de poignée de couvercle droit Cubierta del asa de la tapa Abdeckung des rechten Deckelgriffs |
| 10 | N570-0145 | Handle Assembly Screw Vis d'assemblage de poignée Tornillo de montaje del mango Griff-Montageschraube |
| 11 | N010-10002706 | Handle Lid Assembly Ensemble poignée du couvercle Conjunto del asa de la tapa Griff-Deckel-Baugruppe |
| 12 | N200-10002702-GY1HT | Left Lid Handle Cover Cache de poignée de couvercle gauche Cubierta de la manija izquierda de la tapa Abdeckung des linken Deckelgriffs |
| 13 | N385-0532-SER | Napoleon® Logo Logo Napoleon® Logo Napoleon® Logo Napoleon® |

Hood | Couverture | Cubierta | Haube

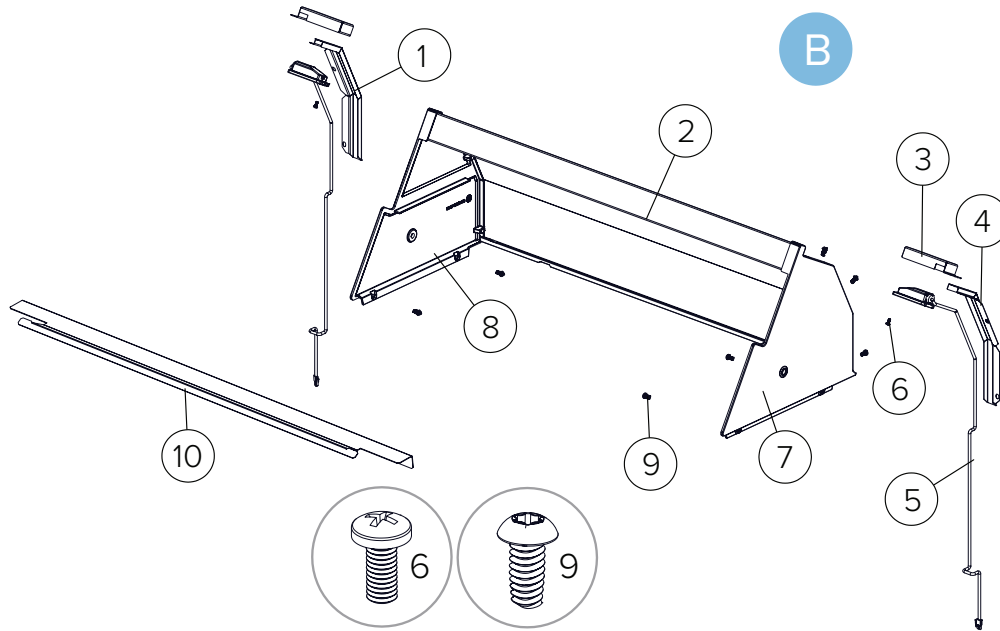

| | Part # | Partie # | Parte # | Teil # | Description Description Descripción Beschreibung |
|----|---------------------|----------|---------|--------|---|
| B | N010-1841 | | | | Hood Assembly with Lights Ensemble capot avec feux Conjunto de la campana con luces Motorhaubenbaugruppe mit Beleuchtung |
| 1 | N200-10002735 | | | | Left Wire Hood Light Cover Couvercle gauche du phare avant gauche Cubierta de la luz de la campana izquierda Linke Kabelhaube für Scheinwerferabdeckung |
| 2 | N335-10002453-BK2GL | | | | Hood Insert Insert de capot Inserto del capó Haubeinsatz |
| 3 | N350-10002734 | | | | Halogen Light Housing Boîtier de lampe halogène Carcasa de la luz halógena Halogenleuchtengehäuse |
| 4 | N200-10002736 | | | | Right Wire Hood Light Cover Couvercle droit de lampe du capot Cubierta de la luz de la campana derecha Rechte Kabelhaube für Scheinwerferabdeckung |
| 5 | N402-10003936 | | | | Halogen Light Lampe halogène Luz halógena Halogenlampe |
| 6 | N570-0022 | | | | Hood Light Screw Vis pour éclairage de capot Tornillo de la luz del capó Haube Licht Schraube |
| 7 | N135-10002432-GY1HT | | | | Hood Casting Right Pièce moulée droite du capot Fundición de la campana derecha Haube rechts gegossen |
| 8 | N135-10002413-GY1HT | | | | Hood Casting Left Pièce moulée gauche du capot Fundición de la campana izquierda Haube, links gegossen |
| 9 | N570-0145 | | | | Hood Assembly Screw Vis d'assemblage du capot Tornillo del conjunto de la cubierta Haubenmontageschraube |
| 10 | N215-10008468 | | | | Wind Deflector déflecteur de vent deflector de viento Windabweiser |

Side Shelf (Display) | Tablette latérale (Affichage) Estante lateral (Pantalla) | Seitenablage (Display)

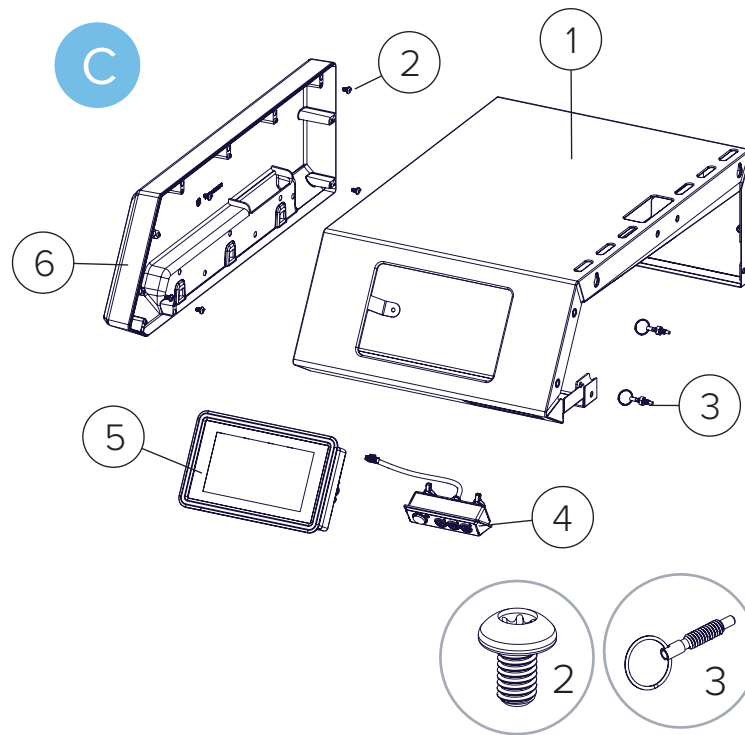

| | Part # Partie # Parte # Teil # | Description Description Descripción Beschreibung |
|---|--------------------------------|---|
| C | N010-10003269-CE | Left Shelf Assembly Ensemble d'étagère gauche Conjunto del estante izquierdo Linke Regalboden-Baugruppe |
| 1 | N010-10007101 | Welded Shelf Assembly Ensemble d'étagère soudée Conjunto del estante izquierdo soldado Geschweißte Regalbaugruppe |
| 2 | N570-0148 | Screw Vis Tornillo Schraube |
| 3 | N485-10006096 | Retractable Spring Pin Goupille à ressort rétractable Pasador de resorte retráctil |
| 4 | N010-10006760 | Probe Receptacle & Firmware Réceptacle de sonde et micrologiciel Receptáculo de sonda y firmware Sondenaufnahme & Firmware |
| 5 | N010-10006780 | Screen & Firmware Écran et micrologiciel Pantalla y firmware Display und Firmware |
| 6 | N135-10001251-GY1HT | Side Shelf Left End Cap Embout d'extrémité gauche de l'étagère latérale Tapa del extremo izquierdo del estante lateral Seitenablage linke Endkappe |

Side Shelf (Infrared Burner) | Tablette latérale (brûleur infrarouge) Estante lateral (quemador infrarrojo) | Seitenablage (Infrarotbrenner)

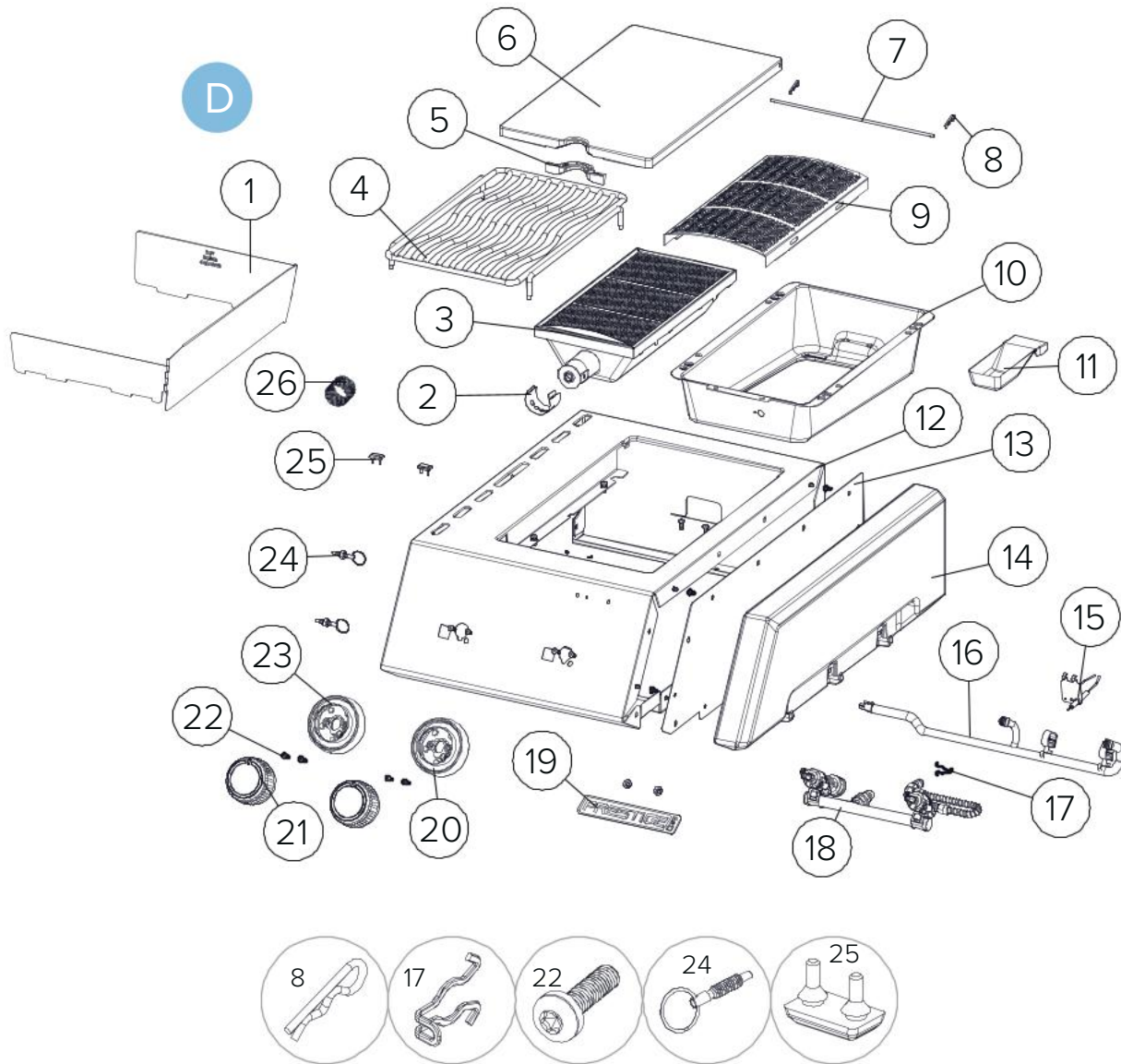

| | Part # Partie # Parte # Teil # | Description Description Descripción Beschreibung |
|---|---|---|
| D | N010-10002815 (LPG) N010-10002815-IL | Infrared Side Shelf Étagère latérale infrarouge Estante lateral infrarrojo Infrarot-Seitenablage |
| 1 | N010-10007424 | Wind Shield Side Burner Assembly Pare-vent Ensemble brûleur latéral Conjunto del quemador lateral con protector contra el viento Windschutz-Seitenbrenner-Baugruppe |
| 2 | N080-10005686 | IR Bracket Support IR Soporte IR IR-Halterung |
| 3 | N010-1725 | Infrared Burner Assembly Ensemble brûleur infrarouge Conjunto del quemador infrarrojo Infrarotbrenner-Baugruppe |

| | Part # Partie # Parte # Teil # | Description Description Descripción Beschreibung |
|----|--------------------------------|--|
| 4 | N305-10001280 | Side burner grid Grille du brûleur latéral rejilla del quemador lateral Seitlicher Brennerrost |
| 5 | N325-10006517 | Lid Handle Poignée du couvercle Asa de la tapa Deckelgriff |
| 6 | N335-0098-M02 | Lid Couvercle Tapa Deckel |
| 7 | N555-0091 | Pivot Rod Tige pivotante Varilla pivotante Drehstange |
| 8 | N485-0021 | Hairpin Cotter Pin Goupille fendue Pasador tipo horquilla Splintfeder |
| 9 | N565-0016 | Curved Screen Écran incurvé Pantalla curvada Gebogener Bildschirm |
| 10 | N500-0079 | Plate Plaque Placa Platte |
| 11 | N710-10008334 | Drip Pan Bac d'égouttement Bandeja recogegotas Auffangwanne |
| 12 | N010-10007102 | Right Side Shelf Étagère droite Estante derecho Rechtes Regal |
| 13 | N120-10001835 | Side Shelf Shield End Cap Capuchon d'extrémité de la tablette latérale Tapa del extremo del protector de la repisa lateral Seitliche Ablage Schutzkappe |
| 14 | N135-10001249-GY1HT | Side Shelf Right End Cap Capuchon d'extrémité droite de la tablette latérale Tapa del extremo derecho de la repisa lateral Seitenablage rechte Endkappe |
| 15 | N240-10002246 | Side Burner Electrode Électrode du brûleur latéral Electrodo del quemador lateral Seitenbrenner-Elektrode |
| 16 | N750-10006266 | Side Shelf Panel Wire Fil du panneau de la tablette latérale Cable del panel de la repisa lateral Seitliche Ablagewand aus Draht |
| 17 | N160-0023 | Orifice Clip Pince à orifice Clip para orificio Öffnungsclip |
| 18 | N010-1833-LPG | Manifold Collecteur Colector Verteiler |
| 19 | N385-10003437 | Prestige PRO Logo Logo Prestige PRO Prestige PRO Logo |
| 20 | N010-10006538 | Bezel Side Burner Assembly Ensemble de brûleur latéral de la lunette Conjunto del quemador lateral del bisel Bezel-Seitenbrenner-Baugruppe |
| 21 | N380-10001883 | Control Knob Bouton de commande Perilla de control Bedienknopf |
| 22 | N570-10003120 | Screw Vis Tornillo Schraube |
| 23 | N010-10006537 | Bezel Rear Burner Assembly Ensemble de brûleur arrière de la lunette Conjunto del quemador trasero del bisel Einbaurahmen für Heckbrenner |
| 24 | N485-10006096 | Retractable Spring Pin Goupille à ressort rétractable Pasador de resorte retráctil Einziehbarer Federstift |
| 25 | N510-0013 | Rectangular Silicone Bumper Pare-chocs rectangulaire en silicone Topes rectangulares de silicona Rechteckiger Silikon-Stoßfänger |
| 26 | N565-10009209 (Israel) | Bug Ir Burner Screen Israel Écran anti-insectes Bug Ir Burner Israël Pantalla quemadora Bug Ir Israel Bug Ir Brenner Bildschirm Israel |

Control Panel | Panneau de contrôle Panel de control | Systemsteuerung

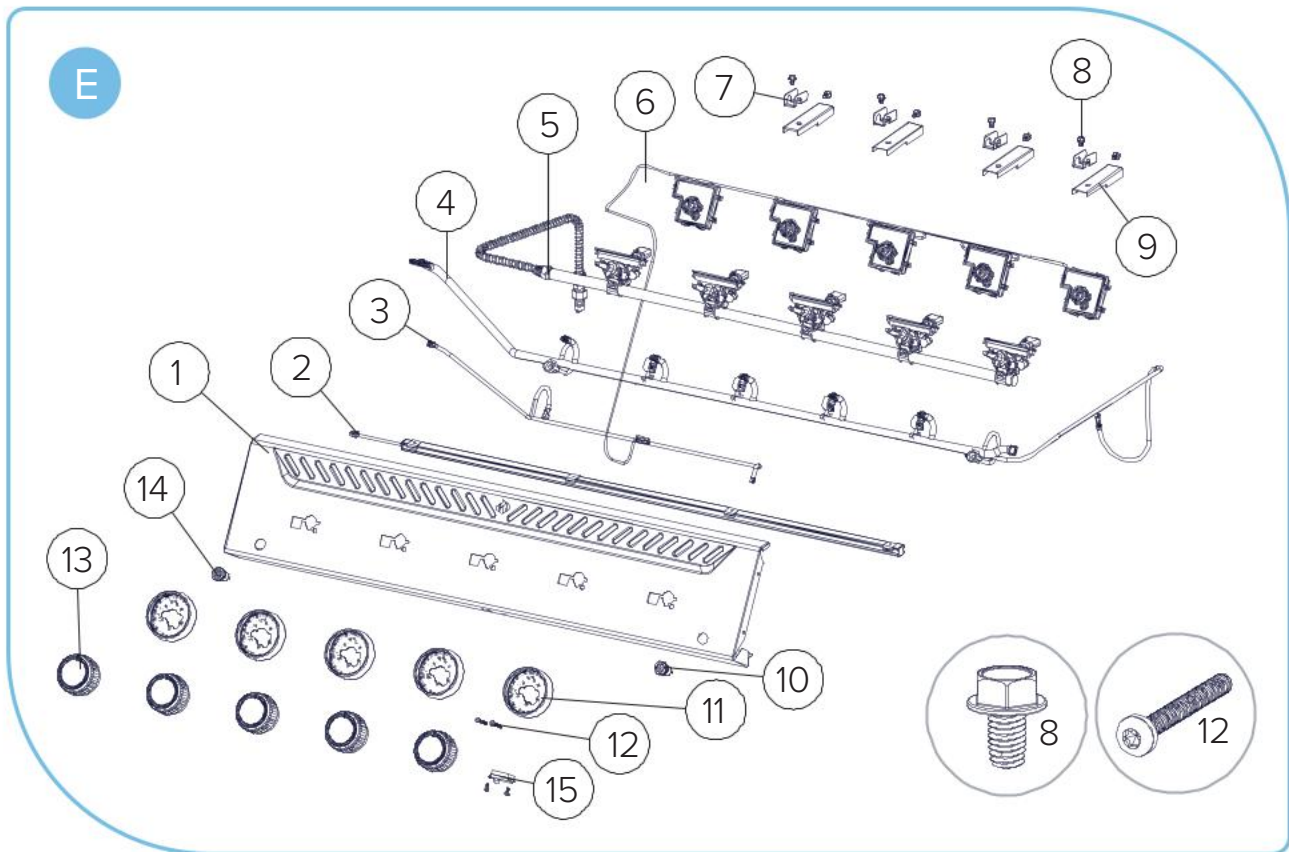
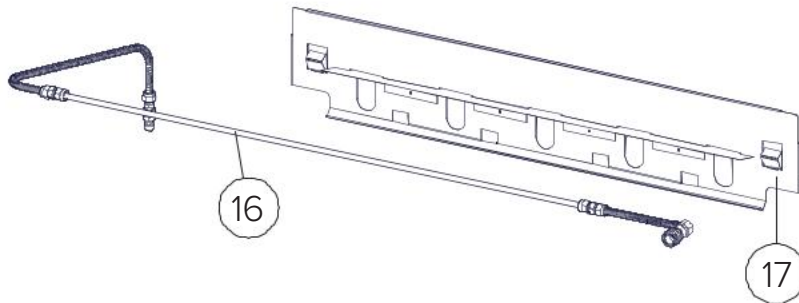

| | Part # Partie # Parte # Teil # | Description Description Descripción Beschreibung |
|---|--------------------------------|---|
| E | N010-1844-LPG | Control Panel Assembly Assemblage du panneau de commande Conjunto del panel de control Kontrolltafel-Baugruppe |
| 1 | N475-10001374 | Control Panel Panneau de commande Panel de control Systemsteuerung |
| 2 | N405-10003276 | LED Rail Light Rail d'éclairage LED Luz LED para riel LED-Schienenleuchte |
| 3 | N750-10005056 | Harness Wire Prox Faisceau de câbles Prox Cable del arnés Prox Kabelbaum Prox |
| 4 | N750-10006833 | Control Panel Wire Câble du panneau de commande Cable del panel de control Bedienfeldkabel |
| 5 | N010-1845-LPG | Manifold Collecteur Colector Verteiler |

| | Part # Partie # Parte # Teil # | Description Description Descripción Beschreibung |
|----|--------------------------------|---|
| 6 | N010-10008297 | Reed Switch Boxes and Harness boîtiers de commutateurs Reed et faisceau cajas de conmutadores de láminas y arnés |
| 7 | N155-10004912 | Manifold B Clamp Pince de collecteur B Abrazadera B del colector Verteiler B-Klemme |
| 8 | N570-0122 | Screw Vis Tornillo Schraube |
| 9 | N155-10003085 | Manifold Clamp Pince de collecteur Abrazadera del colector Verteilerklemme |
| 10 | N660-10006694 | Igniter Switch Interrupteur d'allumage Interruptor del encendedor Zündschalter |
| 11 | N010-10001888 | Bezel Main Burner Assembly Encadrement Ensemble brûleur principal Bisel Conjunto del quemador principal Lünette Hauptbrenner-Baugruppe |
| 12 | N570-10003121 | Screw Vis Tornillo Schraube |
| 13 | N380-10001883-NK3FL | Control Knob Bouton de commande Perilla de control Bedienknopf |
| 14 | N660-10006692 | Power Switch Interrupteur d'alimentation Interruptor de alimentación Netzschalter |
| 15 | N660-10008552 | Proxmtly Sensor Switch Interrupteur de proximité Interruptor del sensor de proximidad Näherungssensor-Schalter |
| 16 | N010-1846 | Gas Supply Assembly Ensemble d'alimentation en gaz Conjunto de suministro de gas Gasversorgungsbaugruppe |
| 17 | N010-10009236 | Control Panel Heat Shield Panneau de commande Bouclier thermique Panel de control Escudo térmico Bedienfeld-Hitzeschild |

Base Assembly | Assemblage de la base Montaje de la base | Basisbaugruppe

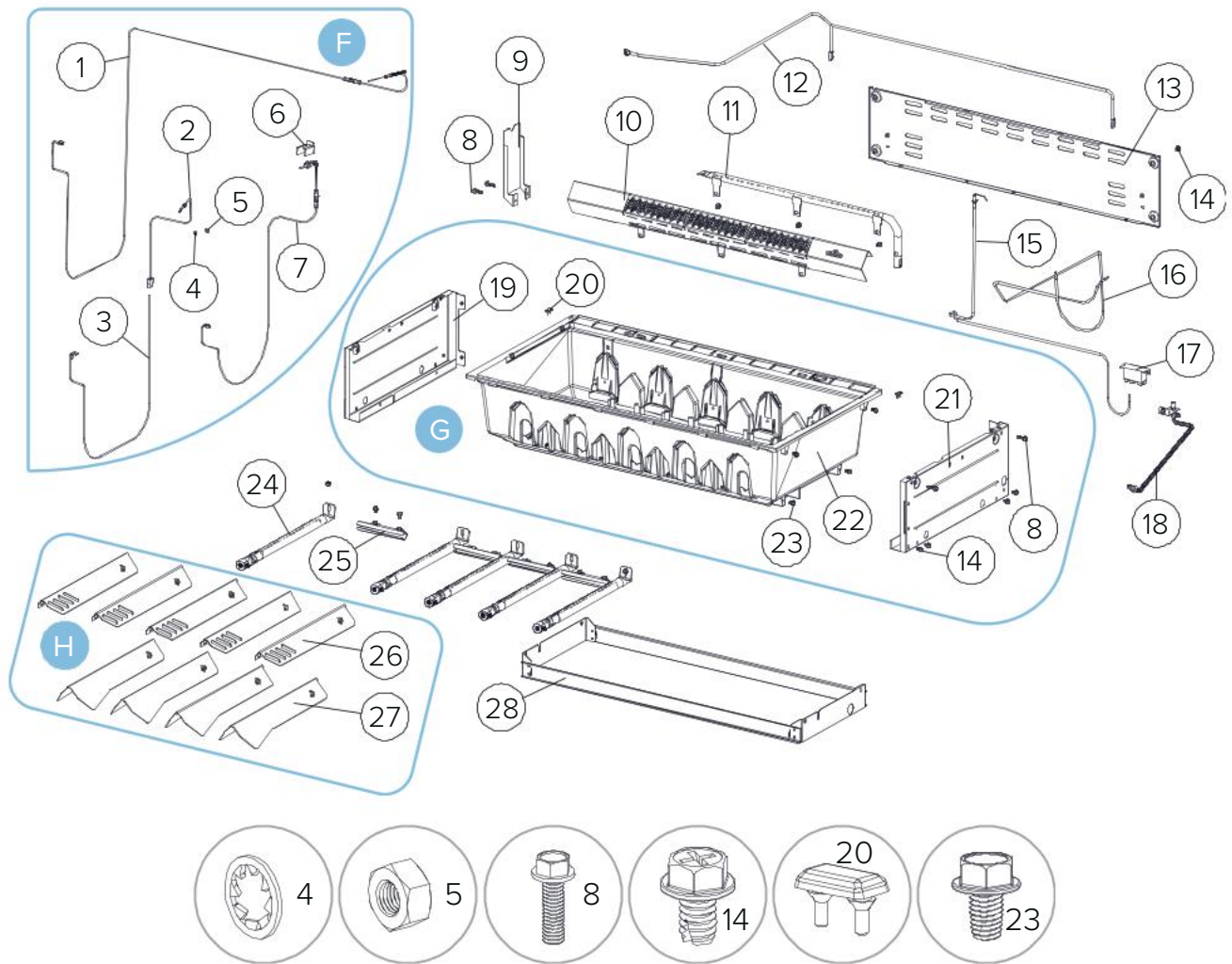

| | Part # Partie # Parte # Teil # | Description Description Descripción Beschreibung |
|---|--------------------------------|--|
| F | N370-1293 | Sensors Kits Kits de capteurs Kits de sensores Sensoren-Kits |
| 1 | N680-10005086 | Burner Thermocouple Thermocouple du brûleur Termopar del quemador Brenner-Thermoelement |
| 2 | N680-10004936 | Flame Sensor Thermocouple Thermocouple du capteur de flamme Termopar del sensor de llama |
| 3 | N680-10005031 | Flame Sensor Extension Wire Câble d'extension du capteur de flamme Cable de extensión del sensor de llama Flammensensor-Verlängerungsleitung |
| 4 | N735-10008254 | Lock Washer Rondelle de blocage Arandela de seguridad Sicherungsscheibe |
| 5 | N450-10008186 | Nut Écrou Tuerca Mutter |
| 6 | N585-10007263 | Base Thermocouple Shield Bouclier de thermocouple de base Protector de termopar de la base Basis-Thermoelement-Abschirmung |
| 7 | N680-10006804 | Ambient Probe Thermocouple Thermocouple de la sonde ambiante Termopar de la sonda ambiental Umgebungsthermometer-Thermoelement |

| | Part # Partie # Parte # Teil # | Description Description Descripción Beschreibung |
|----|--------------------------------|--|
| 8 | N570-0087 | Screw Vis Tornillo Schraube |
| 9 | N080-10003224 | Mount Rotis Motor Bracket Support de moteur Rotis Soporte del motor del monte Rotis Motorhalterung für Mount Rotis |
| 10 | N350-10007855 | Rear Burner Housing Boîtier du brûleur arrière Carcasa del quemador trasero Hinteres Brennergehäuse |
| 11 | N100-0072 | Rear Burner Brûleur arrière Quemador trasero Hinterer Brenner |
| 12 | N750-10006817 | Hood Light Harness Wire Câble du faisceau de la hotte Cable del arnés de la luz de la campana Kabelbaum für Motorhaubenbeleuchtung |
| 13 | N200-10004249-GY1HT | Base Back Cover Couvercle arrière de la base Cubierta trasera de la base Basis-Rückwand |
| 14 | N570-0118 | Screw Vis Tornillo Schraube |
| 15 | N240-0046 | Rear Electrode Wire Câble de l'électrode arrière Cable del electrodo trasero Hinterer Elektrodendraht |
| 16 | N750-10004245 | Side Burner Ignitor Wire Fil d'allumage du brûleur latéral Cable del encendedor del quemador lateral Seitenbrenner-Zündkabel |
| 17 | N357-0021 | Igniter Block Bloc d'allumage Bloque de encendido Zündmodul |
| 18 | N010-1847-LPG | Rear Burner Orifice Assembly Ensemble d'orifice du brûleur arrière Conjunto del orificio del quemador trasero Hintere Brennerdüse |
| G | N010-1829 | Base Assembly Ensemble de base Conjunto de la base Basisbaugruppe |
| 19 | N200-10002819-GY1HT | Base Casting Cover Left Couvercle de fonderie de base gauche Cubierta de fundición de base izquierda linke Grundgussabdeckung |
| 20 | N510-0013 | Rectangular Silicone Bumper Pare-chocs rectangulaire en silicone Parachoques rectangular de silicona Rechteckiger Silikon-Stoßfänger |
| 21 | N200-10002817-GY1HT | Base Casting Cover Right Couvercle de fonderie de base droit Cubierta de fundición de base derecha rechte Grundgussabdeckung |
| 22 | N135-10003805-GY1HT | Aluminum Base Grey Casting Base en aluminium moulé gris Fundición gris de la base de aluminio Aluminium-Gussbasis grau |
| 23 | N570-0022 | Screw Vis Tornillo Schraube |
| 24 | N100-0071 | Main Tube Burner Tube principal du brûleur Quemador de tubo principal Hauptrohrbrenner |
| 25 | S87011 | Cross Light Bracket Support de lampe transversale Soporte de luz cruzada |
| H | N370-1291 | 9 Sear Plates Kit Kit de 9 plaques de cuisson Kit de 9 placas de sellado 9-teiliges Grillplatten-Set |
| 26 | N500-10008718 | Top Sear Plate Plaque de cuisson supérieure Placa superior para sellar Obere Bratplatte |
| 27 | N500-10008717 | Bottom Sear Plate Plaque inférieure de cuisson Placa inferior de sellado Unterer Bratrost |
| 28 | N010-10003342 | Drip Pan Air Flow Reducer Réducteur de débit d'air pour bac d'égouttage Reductor de flujo de aire para bandeja de goteo Tropfschale Luftstromreduzierer |

Cabinet | Armoire | Gabinete | Schrank

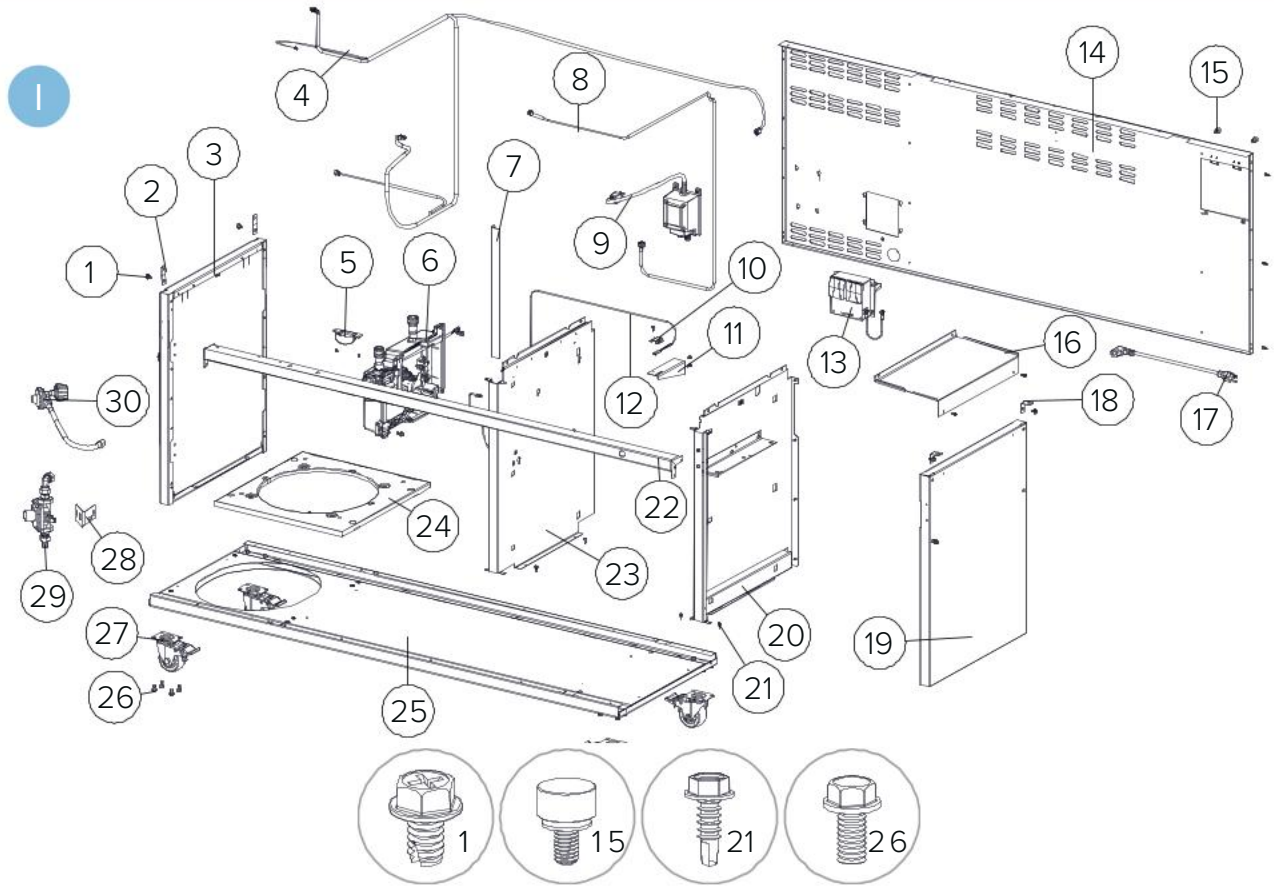

| | Part # | Partie # | Parte # | Teil # | Description Description Descripción Beschreibung |
|---|---------------------|----------|---------|--------|---|
| 1 | N570-0118 | | | | Screw Vis Tornillo Schraube |
| 2 | N080-10005845 | | | | Left Side Shelf Bracket Support d'étagère côté gauche Soporte para estante lateral izquierdo Linke Regalhalterung |
| 3 | N010-10005691 | | | | Left Side Cart Assembly Ensemble de chariot côté gauche Conjunto del carro del lado izquierdo Linke Seitenwagen-Baugruppe |
| 4 | N750-10006909 | | | | Harness Gas Pack Wire Câble de faisceau du bloc gaz Cable del arnés del paquete de gas Gas-Pack-Kabelbaum |
| 5 | N402-0018 | | | | Cabinet Light Éclairage de l'armoire Luz del armario Schrankbeleuchtung |
| 6 | N010-10007033-LPG | | | | Gas Pack Assembly Ensemble bloc gaz Conjunto del paquete de gas Gas-Pack-Baugruppe |
| 7 | N200-10006977-GY1SG | | | | Wire Routing Cover Couvercle pour acheminement des câbles Cubierta para el tendido de cables Kabelkanalabdeckung |
| 8 | N750-10006957 | | | | 12v Power Harness Wire Câble d'alimentation 12 V Cable de arnés de alimentación de 12 V 12-V-Stromkabelbaum |
| 9 | N707-10006260 | | | | Transformer Transformateur Transformador Transformator 240VAC CE (TYPE F) |
| | N707-10006261 | | | | Transformer Transformateur Transformador Transformator 240VAC GB (TYPE G) |
| | N707-10006262 | | | | Transformer Transformateur Transformador Transformator 240VAC IL (TYPE H) |
| | N707-10007328 | | | | Transformer Transformateur Transformador Transformator 240VAC CH (TYPE J) |

| | Part # Partie # Parte # Teil # | Description Description Descripción Beschreibung |
|----|--------------------------------|--|
| 10 | N080-10002711 | Thermostat Holding Clip Clip de fixation pour thermostat Clip de sujeción del termostato Thermostat-Halteklammer |
| 11 | N080-10002721-GY1SG | Thermostat Mount Bracket Support de montage du thermostat Soporte de montaje del termostato Thermostat-Befestigungswinkel |
| 12 | N750-10006822 | Thermostat Snap Disk Disque de déclenchement pour thermostat Disco de fijación del termostato Thermostat-Schnappscheibe |
| 13 | N460-10003518 | Receptacle Réceptacle Recipiente Behälter 1 in - 3 Out Ce (Type F) |
| | N460-10004527 | Receptacle Réceptacle Recipiente Behälter 1 in - 3 OUT GB (Type G) |
| | N460-10004528 | Receptacle Réceptacle Recipiente Behälter 1 in - 3 OUT IL (Type H) |
| | N460-10007314 | Receptacle Réceptacle Recipiente Behälter 1 in - 3 OUT CH (Type J) |
| 14 | N010-1843 | Back Panel with Smoker Door Panneau arrière avec porte pour fumeur Panel trasero con puerta para ahumador Rückwand mit Räuchertür |
| | N010-1843-CH | Back Panel with Smoker Door Switzerland Panneau arrière avec porte pour fumeur Suisse Panel trasero con puerta para ahumador Suiza Rückwand mit Räuchertür Schweiz |
| 15 | N570-10007730 | Thumb Screw Vis à oreilles Tornillo de mariposa Rändelschraube |
| 16 | N215-10006301 | Smoker Box Deflector Déflecteur pour boîte à fumer Deflector para caja de ahumado Räucherbox-Deflektor |
| 17 | N750-10006256 | Power Cord Wire Cordon d'alimentation Cable de alimentación Netzkabel CE (Type F) to C13 |
| | N750-10006257 | Power Cord Wire Cordon d'alimentation Cable de alimentación NetzkabelWire, Power Cord Gb (Type G) to C13 |
| | N750-10006258 | Power Cord Wire Cordon d'alimentation Cable de alimentación Netzkabel IL (TYPE H) to C13 |
| | N750-10007327 | Power Cord Wire Cordon d'alimentation Cable de alimentación Netzkabel CH (TYPE J) to C13 |
| 18 | N080-10005846 | Right Side Shelf Anchor Bracket Support d'ancrage pour étagère droite Soporte de anclaje para estante derecho Ankerhalterung für Regal rechts |
| 19 | N010-10005690 | Right Side Cart Assembly Ensemble chariot côté droit Conjunto del carro del lado derecho Rechte Seite Wagenmontage |
| 20 | N010-10005692 | Right Divider Cart Assembly Assemblage du chariot à séparateur droit Conjunto del carro divisor derecho Rechte Trennwand-Wagen-Baugruppe |
| 21 | N570-0008 | Screw Vis Tornillo Schraube |
| 22 | N715-10001022-GY1SG | Front Top Trim Garniture supérieure avant Moldura superior delantera Vordere obere Verkleidung |
| 23 | N475-10000713-GY1SG | Left Base Mounting Panel Panneau de montage de base gauche Panel de montaje de la base izquierda Linke Basis-Montageplatte |
| 24 | N710-10001421-GY1SG | Scale Mount Tank Tray Plateau pour réservoir à montage sur échelle Bandeja para tanque con montaje en escala Waage für Tankablaufwanne |
| 25 | N010-10005693 | Bottom Cart Shelf Tablette inférieure du chariot Estante inferior del carro Unteres Wagenregal |
| 26 | N570-0024 | Hex Black Caster Screw Vis à tête hexagonale noire Tornillo de rueda giratoria negro hexagonal Sechskantschraube schwarz |
| 27 | N130-10001618-GY1SG | Caster Wheel Roulette Rueda giratoria Lenkrolle |

| | Part # Partie # Parte # Teil # | Description Description Descripción Beschreibung |
|-----------|---|--|
| 28 | N080-10006469-GY1SG | IN-LINE LPG Regulator Bracket Support pour régulateur de GPL en ligne Soporte para regulador de GLP en línea IN-LINE-LPG-Reglerhalterung |
| 29 | N530-0023-SER | Regulator Régulateur Regulador Regulierungsbehörde |
| | N530-0023-FR | Regulator France Régulateur France Regulador Francia Regulierungsbehörde Frankreich |
| 30 | N530-0032 | Regulator Hose for Germany Tuyau régulateur pour l'Allemagne Manguera reguladora para Alemania Regulatorschlauch für Deutschland |
| | N530-0033 | Regulator Hose for Holland Tuyau régulateur pour Hollande Manguera reguladora para Holanda Regulatorschlauch für Holland |
| | N530-0034 | Regulator Hose for Denmark/Spain/Finnish/Norway Tuyau régulateur pour Danemark/ Espagne/Finlande/Norvège Manguera reguladora para Holanda Regulatorschlauch für Dänemark/Spanien/Finnland/Norwegen |
| | N530-0035 | Regulator Hose for Sweden Tuyau régulateur pour Suède Manguera reguladora para Suecia Regulatorschlauch für Schweden |
| | N530-0036 | Regulator Hose for Italy/Greece Tuyau régulateur pour Italie/Grèce Manguera reguladora para Italia/Grecia Regulatorschlauch für Italien/Griechenland |
| | N530-0037 | Regulator Hose for UK Tuyau régulateur pour Royaume-Uni Manguera reguladora para Reino Unido Regulatorschlauch für Vereinigtes Königreich |
| | N530-0038 | Regulator Hose for France Tuyau régulateur pour France Manguera reguladora para Francia Regulatorschlauch für Frankreich |
| | N530-0039 | Regulator Hose for Hungary Tuyau régulateur pour Hongrie Manguera reguladora para Hungría Regulatorschlauch für Ungarn |
| | N530-0042 | Regulator Hose for Switzerland Tuyau régulateur pour Suisse Manguera reguladora para Suiza Regulatorschlauch für Schweiz |
| | N530-0043 | Regulator Hose for Russia Tuyau régulateur pour Russie Manguera reguladora para Rusia Regulatorschlauch für Russland |
| N530-0046 | Regulator Hose for Czech/Croat/Slove Tuyau régulateur pour Tchéque/Croate/Slovène Manguera reguladora para Checo/Croata/Esloveno Regulatorschlauch für Tschechisch/Kroatisch/Slowenisch | |
| * | N160-10005216 | Nylon Wire Routing Clip Clip de routage de câble en nylon Clip de nylon para el cableado Nylon-Kabelbinder |
| * | W160-0057 | Wire Clip Clip de câble Clip para cables Drahtklammer |

Door | Porte | Puerta | Tür

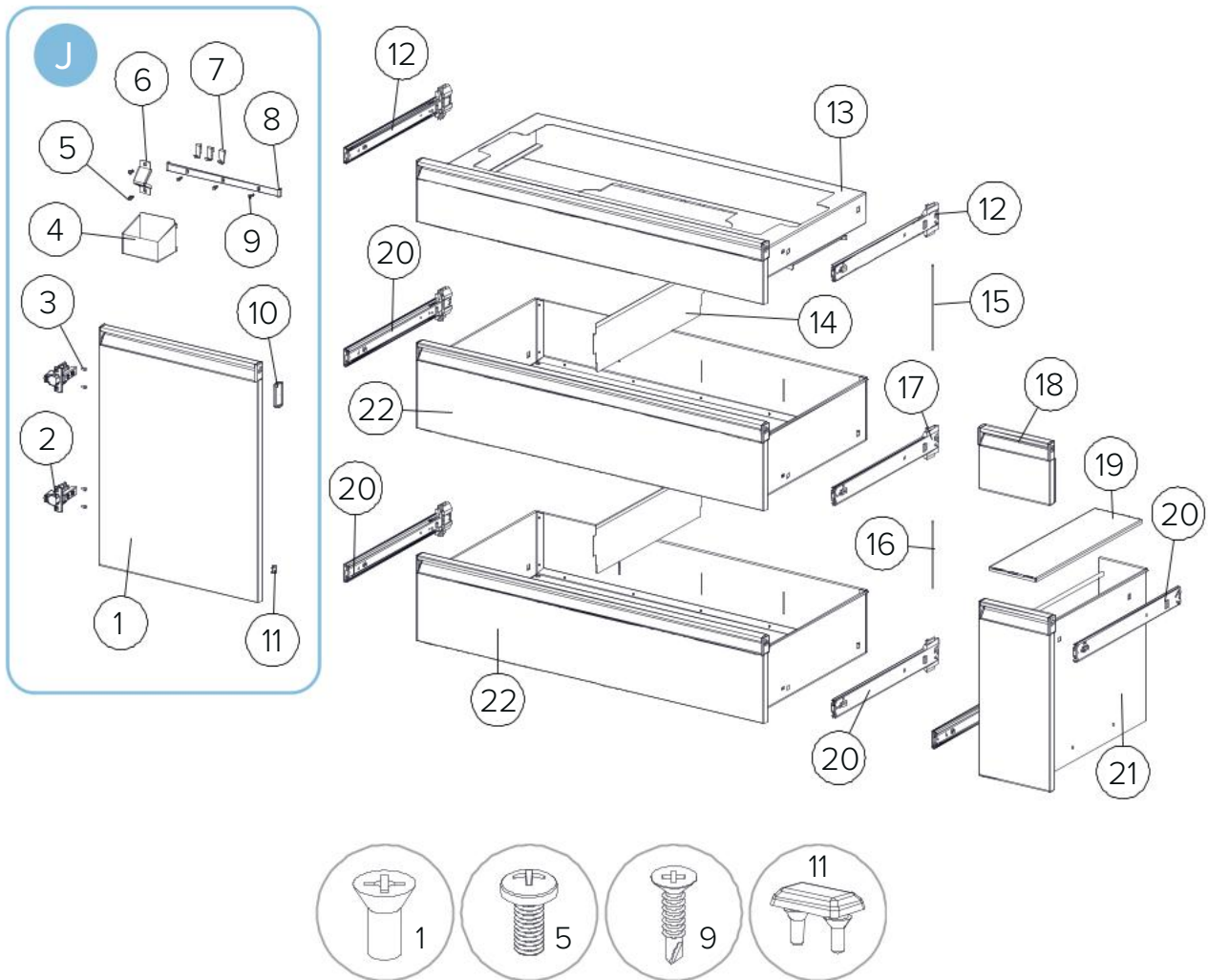

| | Part # Partie # Parte # Teil # | Description Description Descripción Beschreibung |
|---|--------------------------------|---|
| J | N010-1848-SS | Left Door Kit Kit porte gauche Kit puerta izquierda Linkes Tür-Set |
| 1 | N010-10000707 | Door Assembly left Assemblage de porte gauche Conjunto de puerta izquierda Türmontage links |
| 2 | N330-10001785 | Hinge Charnière Bisagra Scharnier |
| 3 | N570-0070 | Hinge Screws Vis de charnière Tornillos para bisagra Scharnierschrauben |
| 4 | N185-0005 | Bottle Caps Container Récipient pour capsules de bouteilles Contenedor para tapones de botellas Flaschenverschlussbehälter |
| 5 | N570-0022 | Screw Vis Tornillo Schraube |
| 6 | Z080-0012 | Bottle Opener Ouvre-bouteille Abrebotellas Flaschenöffner |
| 7 | N340-10000064 | Door Hook Crochet de porte Gancho para puerta Türhaken |
| 8 | N010-10000062 | Door Hooks Accessory Crochets de porte Accessoire Accesorios para ganchos de puerta Türhaken Zubehör |
| 9 | N570-0146 | Screw Vis Tornillo Schraube |

| | Part # Partie # Parte # Teil # | Description Description Descripción Beschreibung |
|----|--------------------------------|--|
| 10 | N430-10005373 | Door Catch Magnet Aimant de loquet de porte Imán de cierre de puerta Türfangmagnet |
| 11 | N510-0013 | Bumper Pare-chocs Parachoques Stoßstange |
| 12 | N610-10006983 | Drawer Slide 100 lb Glissière de tiroir 100 lb Guía para cajones 100 lb Schubladenführung 100 lb |
| 13 | N010-10001007 | Drawer Pan Tiroir Bandeja para cajones Schubladenwanne |
| 14 | N475-10004957 | Drawer Divider Séparateur de tiroir Separador de cajones Schubladeneinteilung |
| 15 | N555-10006985 | Interlock Rod 5x215 mm Tige de verrouillage 5 x 215 mm Barra de enclavamiento 5x215 mm Verriegelungsstange 5 x 215 mm |
| 16 | N555-10006984 | Interlock Rod 5x170 mm Tige de verrouillage 5 x 170 mm Barra de enclavamiento 5x170 mm Verriegelungsstange 5 x 170 mm |
| 17 | N610-10005534 | Drawer Slide 200 lb Glissière de tiroir 200 lb Guía para cajones de 200 lb Schubladenführung 200 lb |
| 18 | N010-10003273 | Sidesmoker Door Porte latérale Puerta lateral para ahumadores Seitliche Rauchklappe |
| 19 | N590-10001461 | Condiment Shelf Étagère à condiments Estante para condimentos Gewürzregal |
| 20 | N610-10006998 | Drawer Slide 100 lb Glissière de tiroir 100 lb Guía para cajones de 100 lb Schubladenführung 100 lb |
| 21 | N010-10000715 | Condiment Drawer Tiroir à condiments Cajón para condimentos Gewürzschublade |
| 22 | N010-10001015 | Drawer Tiroir Cajón Schublade |

Components | Composants | Componentes | Komponenten

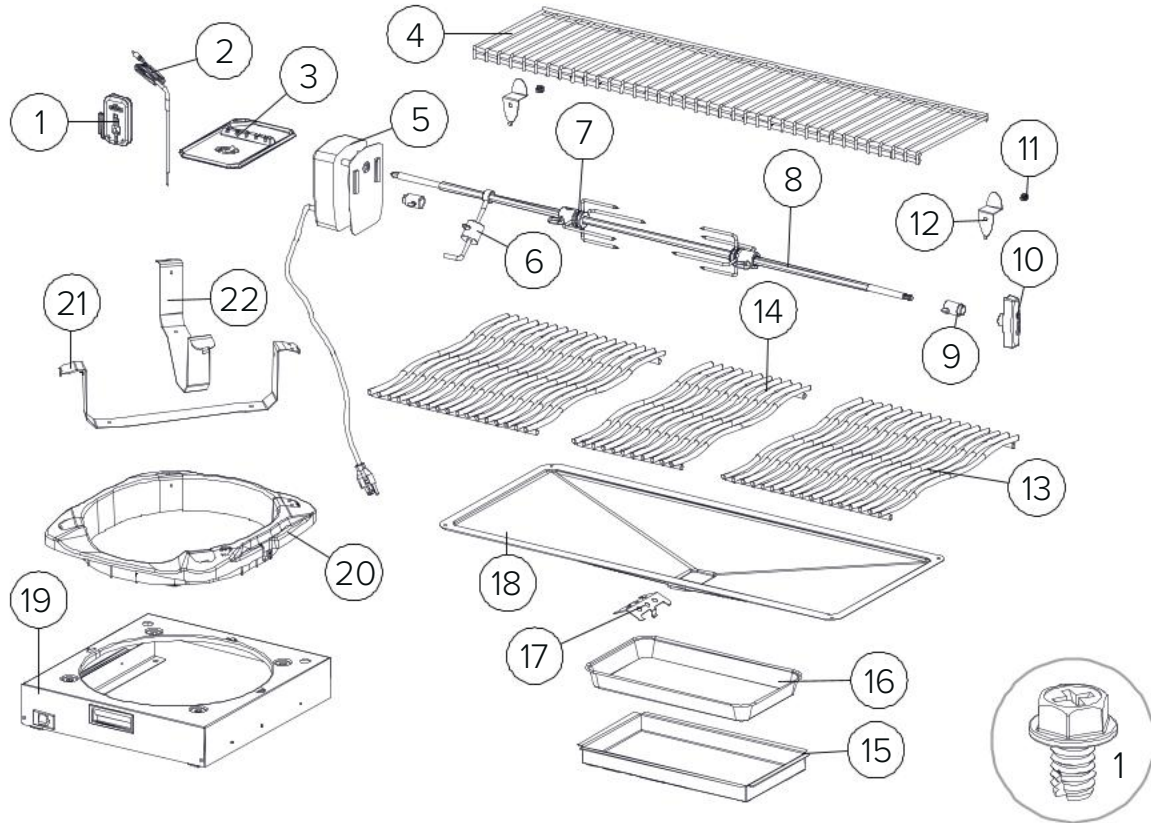

| | Part # | Partie # | Parte # | Teil # | Description Description Descripción Beschreibung |
|----|---------------|----------|---------|--------|--|
| 1 | N350-10002764 | | | | Wired Temp Probe Housing Boîtier de sonde de température filaire Carcasa de sonda de temperatura con cable |
| 2 | N680-0003 | | | | Wired Curved Thermoprobe Sonde thermique courbée filaire Sonda térmica curvada con cable Kabelgebundene gebogene Thermosonde |
| 3 | N465-10007515 | | | | Temp Probe Holder Pad Support de sonde de température Almohadilla para soporte de sonda de temperatura Temperaturfühlerhalterung |
| 4 | N520-0037 | | | | Warming Rack Grille de réchauffage Rejilla calentadora Wärmeschrank |
| 5 | 65032 | | | | Rotisserie Motor Moteur de rôtissoire Motor para asador Rotisserie-Motor CE (TYPE F) |
| | 65033 | | | | Rotisserie Motor Moteur de rôtissoire Motor para asador Rotisserie-Motor GB (TYPE G) |
| | 65035 | | | | Rotisserie Motor Moteur de rôtissoire Motor para asador Rotisserie-Motor IL (TYPE H) |
| | 65036 | | | | Rotisserie Motor Moteur de rôtissoire Motor para asador Rotisserie-Motor CH (TYPE J) |
| 6 | N370-0329 | | | | Kit Counter Balance Rotis Kit de contrepoids pour rôtissoire Kit de contrapeso para asador giratorio Kit Gegengewicht Rotis |
| 7 | N275-0004 | | | | Folding Forks Fourchettes pliantes Tenedores plegables Klappgabeln |
| 8 | N555-0077 | | | | Spit Rotis Broche à rôtir Asador giratorio Spuck-Rotis |
| 9 | N105-10007358 | | | | Bushing Stop Butée de douille Tope de buje Buchsenanschlag |
| 10 | N325-0079 | | | | T Handle Rotisserie Rod Tige de rôtissoire à poignée en T Varilla para asador con mango en T T-Griff-Drehspieß |

| | Part # Partie # Parte # Teil # | Description Description Descripción Beschreibung |
|----|--------------------------------|---|
| 11 | N570-0118 | Screw Vis Tornillo Schraube |
| 12 | N340-10008615-GY0TX | Rotisserie Rod Storage Hook Crochet de rangement pour tige de rôtissoire Gancho para guardar la varilla del asador Aufbewahrungshaken für Grillspieß |
| 13 | N305-0154 | Cooking Grid Main Grille de cuisson principale Parrilla de cocina principal Kochrost Hauptseite |
| 14 | N305-0155 | Cooking Grid Grille de cuisson Rejilla de cocción Kochrost |
| 15 | N200-10008585 | Grease Tray Bac à graisse Bandeja para grasa Fettpfanne |
| 16 | 62008 | Grease Trays Kit Kit de bacs à graisse Kit de bandejas para grasa Fettfangschalen-Set |
| 17 | N215-10002068 | Drip Pan Air Deflector Déflecteur d'air pour bac d'égouttage Deflector de aire para bandeja de goteo Tropfschale Luftleitblech |
| 18 | N710-10001626 | Porcelainized Drip Pan Bac d'égouttage en porcelaine Bandeja de goteo porcelanizada Porzellanbeschichtete Auffangwanne |
| 19 | N010-10003673 | Propane Tank Slide Glissière pour réservoir de propane Deslizamiento del tanque de propano Propantank-Schieber |
| 20 | N370-1294-CE | Propane Tank Scale Assembly Ensemble de balance pour bouteille de propane Conjunto de báscula para tanque de propano Propantank-Waagenbaugruppe |
| 21 | N080-10001741-GY1SG | Tank Scale Right Bracket Support droit pour balance de réservoir Soporte derecho para báscula de tanque Tankwaage rechte Halterung CE |
| 22 | N080-10001753-GY1SG | Tank Scale Left Bracket Support gauche pour balance de réservoir Soporte izquierdo para báscula de tanque Tankwaage linke Halterung CE |

Smoker | Fumeur | Fumador | Raucher

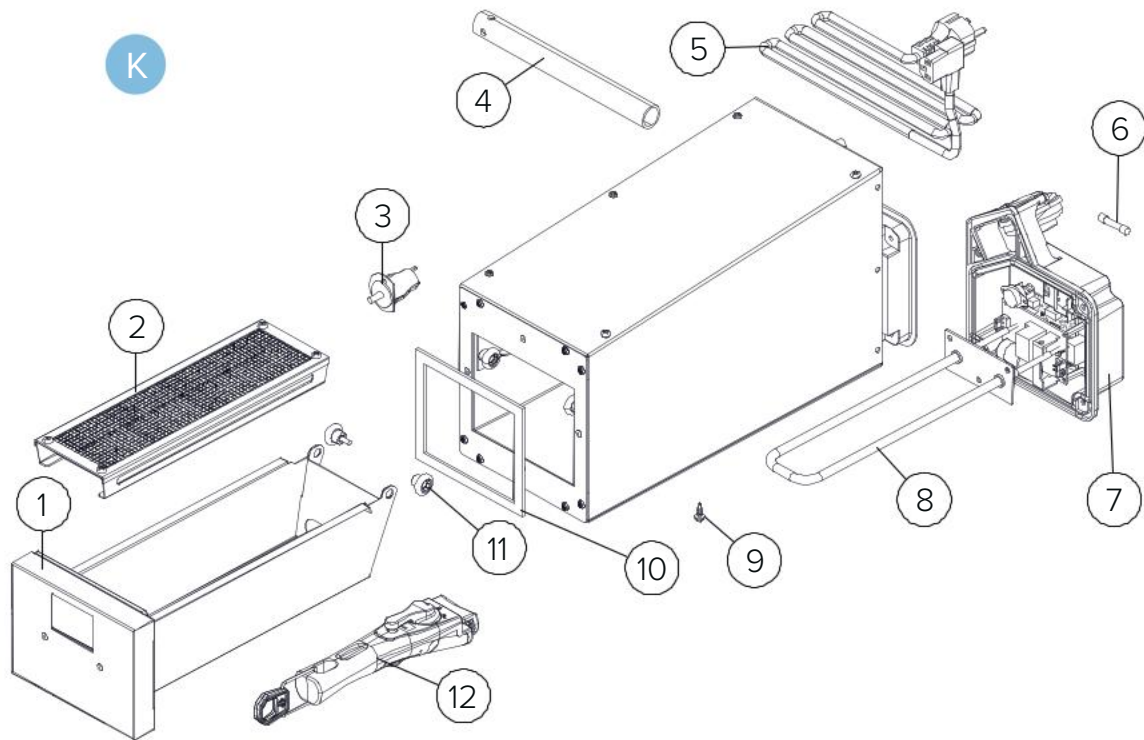

| | Part # Partie # Parte # Teil # | Description Description Descripción Beschreibung |
|----|--------------------------------|---|
| K | N010-10005536 | Side Smoker Fumoir latéral Ahumador lateral Seitlicher Räucherofen |
| 1 | N710-10008867 | Smoke Chip Tray Plateau à copeaux de bois Bandeja para virutas de madera Räucherchipschale Räucherchip-Auffangschale |
| 2 | N360-10008868 | Wood Chip Mesh Grille à copeaux de bois Malla para virutas de madera Holzchip-Sieb |
| 3 | N660-10008859 | Door Switch Interrupteur de porte Interruptor de puerta Türschalter |
| 4 | N490-10008860 | Outlet Pipe Tuyau d'évacuation Tubo de salida Auslassrohr |
| 5 | N195-10008898 | RC/European Common Cord Cordon d'alimentation Cable tipo C Type C Europäischer Standardstecker Typ C |
| | N195-10008897 | United Kingdom Cord Cordon d'alimentation Cable tipo Type G Stecker Typ G |
| | N195-10008896 | Israel Cord Cordon d'alimentation Cable tipo Type H Israel Stecker Typ H |
| | N195-10008895 | Switzerland Cord Cordon d'alimentation Cable tipo Type J Schweiz Stecker Typ J |
| 6 | N285-10008949 | Electronics Box Fuse Fusible du boîtier électronique Fusible de la caja electrónica Elektronikbox-Sicherung |
| 7 | N010-10008863 | Electronics Électronique Electrónica Elektronik 220-240v |
| 8 | N357-10008866 | Heating Element Igniter Allumeur d'élément chauffant Encendedor Elemento calefactor Heizelement-Zünde 120v |
| 9 | N570-0008 | Screw Vis Tornillo Schraube |
| 10 | N290-10008861 | Door Tray Gasket Joint du plateau de porte Junta de la bandeja de la puerta Türdichtung |
| 11 | N045-0001 | Bearing Roulement Rodamiento Lager |
| 12 | N700-10008870 | Tray Removal Tool Outil de retrait du plateau Herramienta para retirar la bandeja Werkzeug zum Entfernen der Auffangschale |



50 Years of Home
Comfort Solutions.
50 ans de solutions de
confort à domicile.
50 años de soluciones de
confort para el hogar.
50 Jahre Lösungen für
Wohnkomfort.



NAPOLEON® products are protected by one or more U.S. and Canadian and/or foreign patents or patents pending.

Les produits de NAPOLEON® sont protégés par un ou plusieurs brevets américains, canadiens et/ou étrangers au par des brevets en instance.

Los productos NAPOLEON® están protegidos por una o más patentes o patentes pendientes en E.U., Canadá y/u otros países.

NAPOLEON® -Produkte sind durch ein oder mehrere US-amerikanische und kanadische und/oder ausländische Patente oder angemeldete Patente geschützt.



Address | Adresse
Dirección | Adresse

Wolf Steel Ltd.®

De Riemsdijk 22, 4004 LC,
Tiel, The Netherlands
10-12 Home Farm, Meriden Road,
Berkswell, CV7 7SL,
United Kingdom
24 Napoleon Road, Barrie,
Ontario, L4M 0G8, Canada



Phone | Téléphone
Teléfono | Telefon

Europe | Europa

+31 (0) 88 588 66 55

Online | En ligne
En línea | Online

✉ eu.info@napoleon.com

🌐 www.napoleon.com