

80458

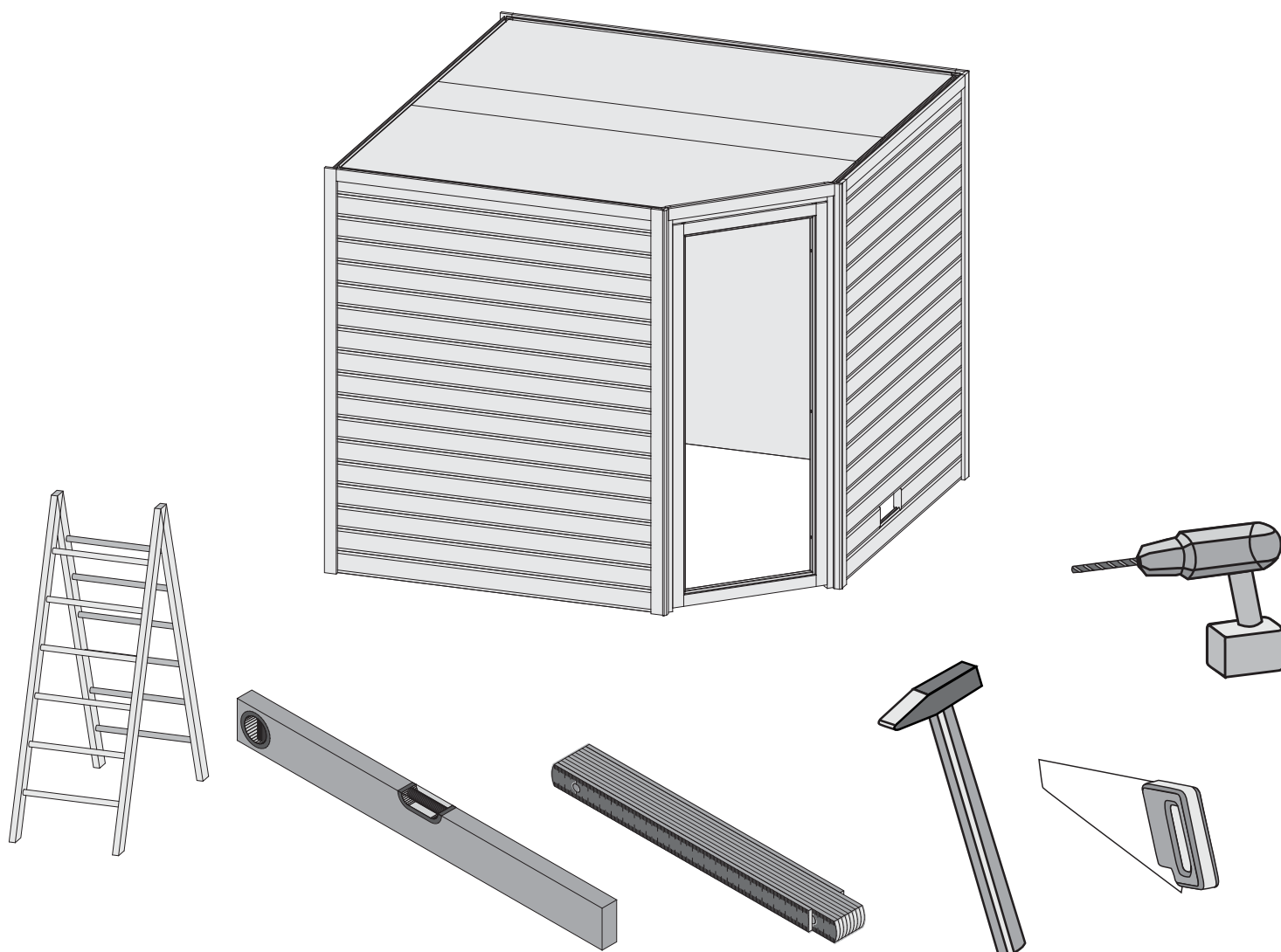

 **Aufbauanleitung**

 **notice de montage**

 **Building Instructions**

 **montagehandleiding**

 **Instrucciones de construcción**

 **Istruzioni per il montaggio**

 **Montážní návod**

 **Service-Hotline: +49 421 38693 33**



Vergleichen Sie zuerst die Materialliste mit Ihrem Paketinhalt! Bitte haben Sie Verständnis, dass Beanstandungen nur im nicht aufgebauten Zustand bearbeitet werden können!



En primer lugar, compare la lista de material con el contenido del paquete. Rogamos entienda que las reclamaciones sólo pueden ser tramitadas antes de montar el objeto!



Nejprve přezkontrolujte obsah balení podle materiálového listu! Mějte pochopení pro to, že případnou reklamaci se můžeme zabývat pouze tehdy, když díly nebudou smontované! Za pomoci tohoto seznamu můžete jednotlivé díly přiřadit k montážnímu návodu.



Vergelijk eerst de lijst van materialen met de inhoud van uw pakket! Reclamaties kunnen alleen in behandeling worden genomen zolang de onderdelen nog niet zijn gemonteerd!



First compare the list of materials with your package contents! Please understand that complaints can be processed in the non-built status only!



Commencez par comparer la liste du matériel avec le contenu de votre paquet! Sachez que nous traitons uniquement les réclamations concernant le matériel à l'état non monté!



Confrontate questa distinta materiali prima con il contenuto del pacchetto! Vi preghiamo di comprendere che eventuali reclami possono essere accolti solo prima del montaggio!

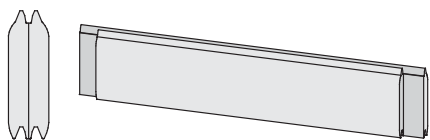
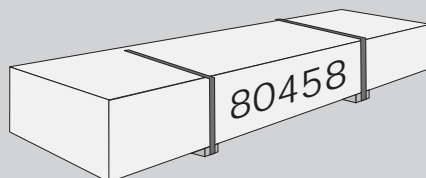

35 x A1	1628 x 121 x 38mm	ID 26150
35 x A2	2231 x 121 x 38mm	ID 21463

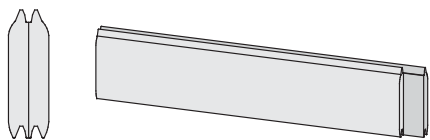

1 x A3	545 x 121 x 38mm	ID 21876
1 x A4	808 x 121 x 38mm	ID 80499

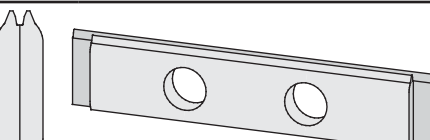

1 x A5	2231 x 121 x 38mm	ID 21866
--------	-------------------	----------

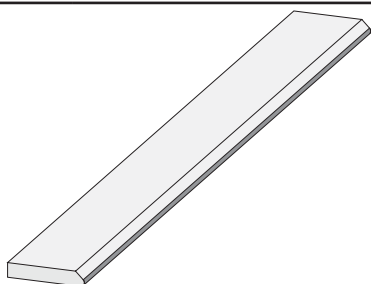

2 x F1	2000 x 58 x 17mm	ID 48545
--------	------------------	----------

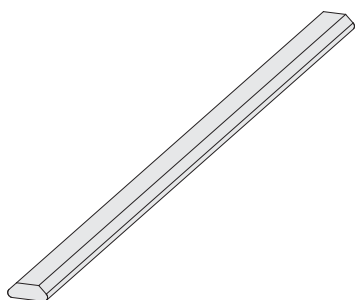

2 x F2	2100 x 45 x 18mm	ID 80276
--------	------------------	----------

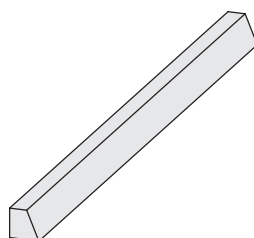

2 x C1	1916 x 36 x 36mm	ID 21814
2 x C2	1973 x 36 x 36mm	ID 21825

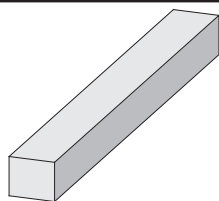

2 x B1	1920 x 20 x 3mm	ID 20799
1 x B2	1608 x 90 x 16mm	ID 72097
2 x B3	2156 x 90 x 16mm	ID 71514
1 x B4	850 x 58 x 17mm	ID 48544
6 x B5	2000 x 58 x 17mm	ID 48541
1 x B6	2250 x 58 x 17mm	ID 48543
2 x B7	800 x 45 x 18mm	ID 24796
1 x B8	880 x 45 x 18mm	ID 21440
2 x B9	1556 x 45 x 18mm	ID 47603
2 x B10	2159 x 45 x 18mm	ID 21483
1 x B11	300 x 95 x 18mm	ID 19130
4 x B12	480 x 95 x 18mm	ID 20930
4 x B13	565 x 95 x 18mm	ID 15498
2 x B14	800 x 58 x 28mm	ID 15493
3 x B15	1916 x 36 x 36mm	ID 21431
1 x B16	781 x 78 x 38mm	ID 56718

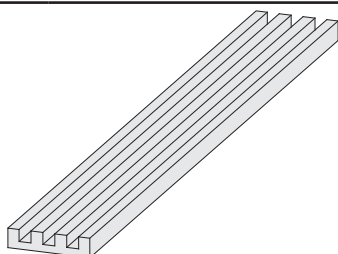

1 x E1	1820 x 110 x 26mm	ID 26480
--------	-------------------	----------

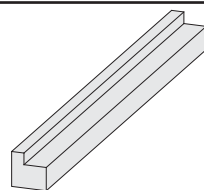

3 x E2	555 x 45 x 45mm	ID 40301
2 x E3	1100 x 45 x 45mm	ID 40302

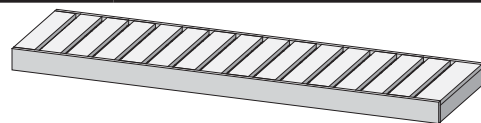

1 x L1	1610 x 500 x 90mm	ID 52067
2 x L2	2156 x 550 x 90mm	ID 52068

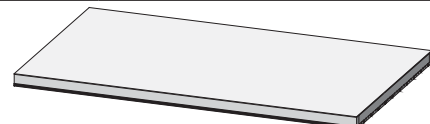

1 x M1	2189 x 350 x 57mm	ID 21482
1 x M2	2189 x 918 x 57mm	ID 21465

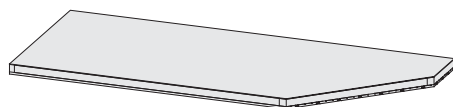

1 x M3	2189 x 918 x 57mm	ID 26152
--------	-------------------	----------



- Siehe Türpaket
- Opmerking Door Package
- Note Door Package
- Remarque Package porte
- Nota Paquete Puerta
- Nota Door Package
- Poznámka Door balíček

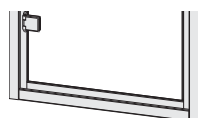

1 x D1		
--------	--	--

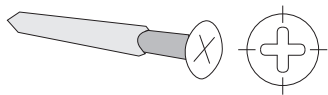

20 x	4 x 30mm	ID 3686
60 x	4 x 35mm	ID 3687
350 x	4 x 40mm	ID 21925
40 x	4 x 50mm	ID 3688
30 x	4 x 70mm	ID 3689
25 x	4,5 x 80mm	ID 9204
20 x	6 x 60mm	ID 14014
20 x	6 x 80mm	ID 47558
80 x	6 x 90mm	ID 26715

10m

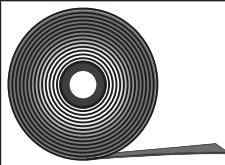

ID 14025

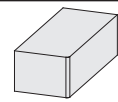

4 x K1

60 x 36 x 36mm

ID 5512

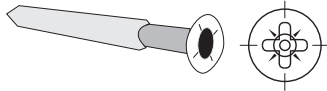

60 x

4,5 x 40mm

ID 26285

2 x

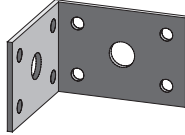

ID 20803



60 x S1	4 x 30mm	ID 26116
6 x S2	12 x 18mm	ID 46403

3 x S3



ID 14018



>10cm

>10cm



01

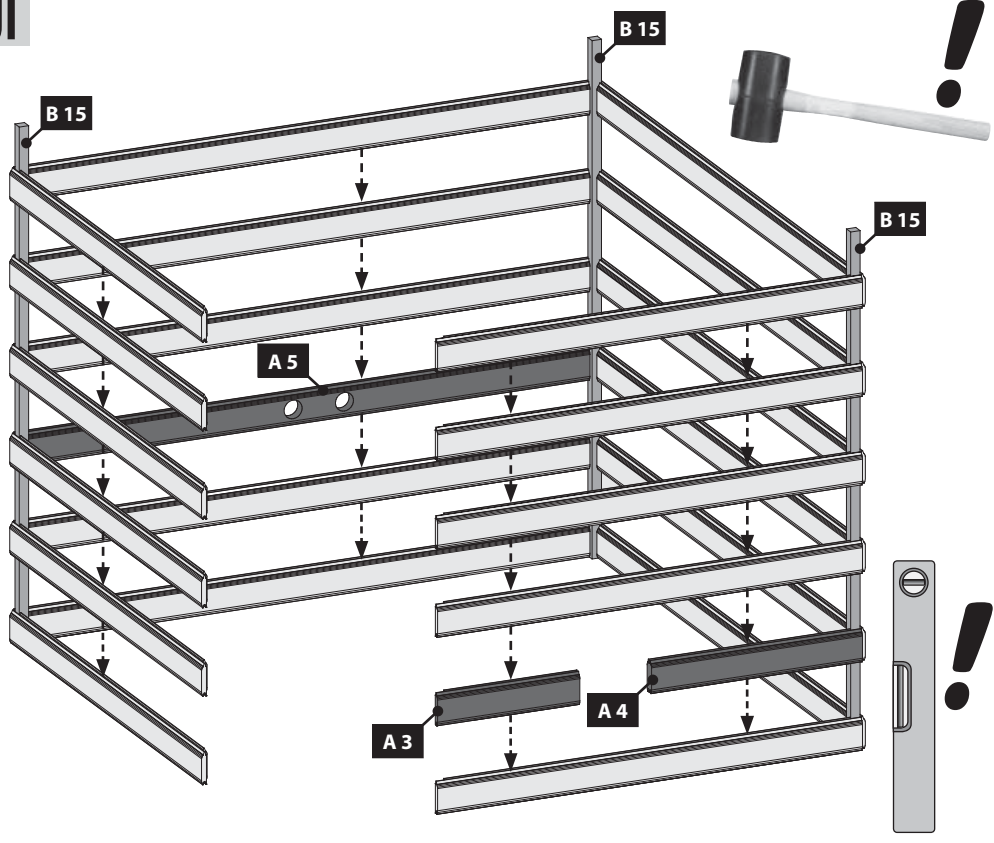

02.1

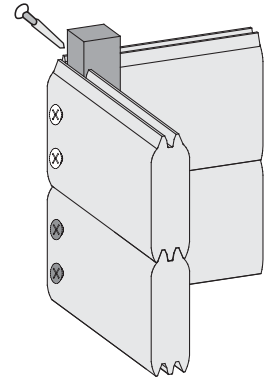

02.2

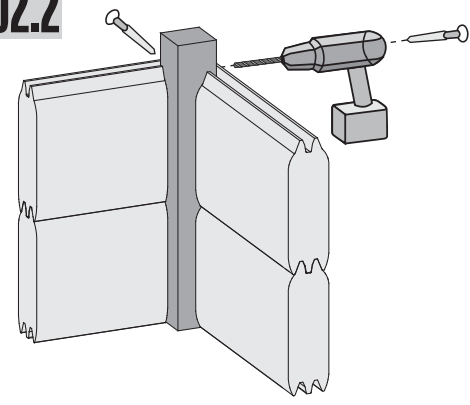

02.3

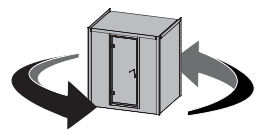

Achten Sie auf die gleiche Höhe
 Look for the same height
 Faites attention à la même hauteur
 Besteed aandacht aan de dezelfde hoogte

Prestar atención a la misma altura
 Prestare attenzione alla stessa altezza
 Dávejte pozor na stejnou výšku

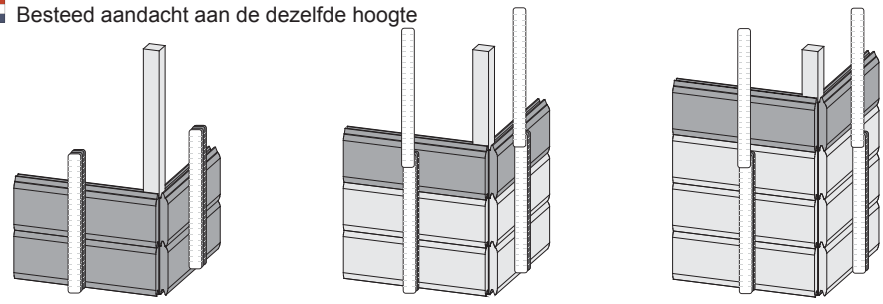

02

(02.1 + 02.2 → 02.3)

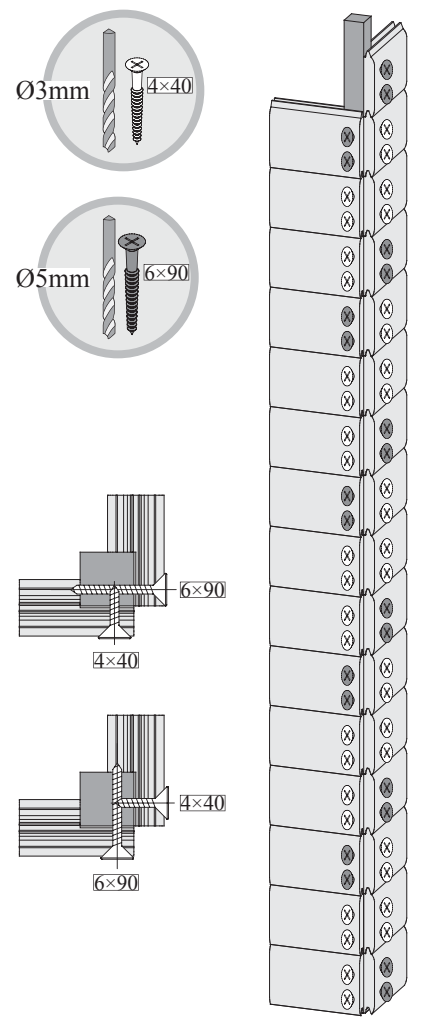
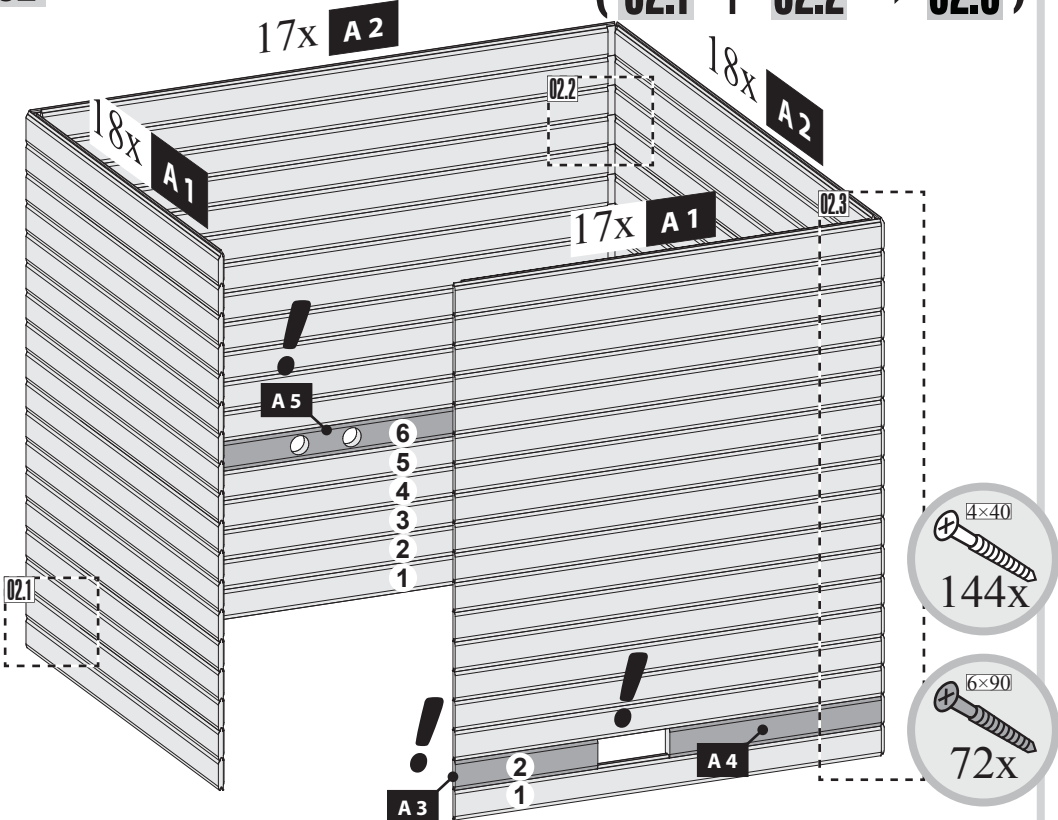

03

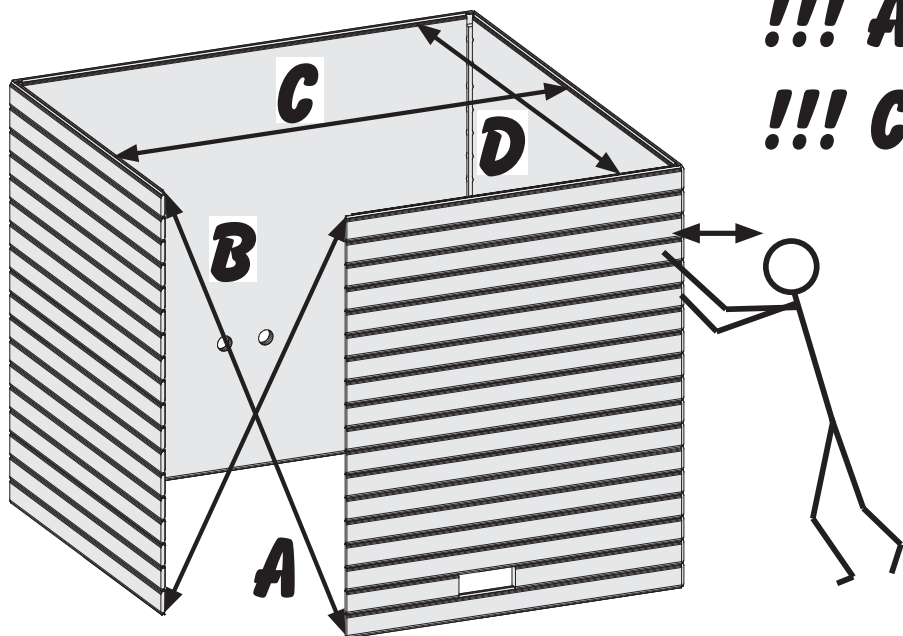

!!! A=B !!!
!!! C=D !!!

04.1

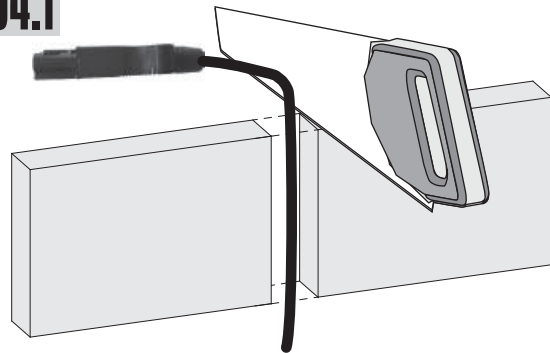

04

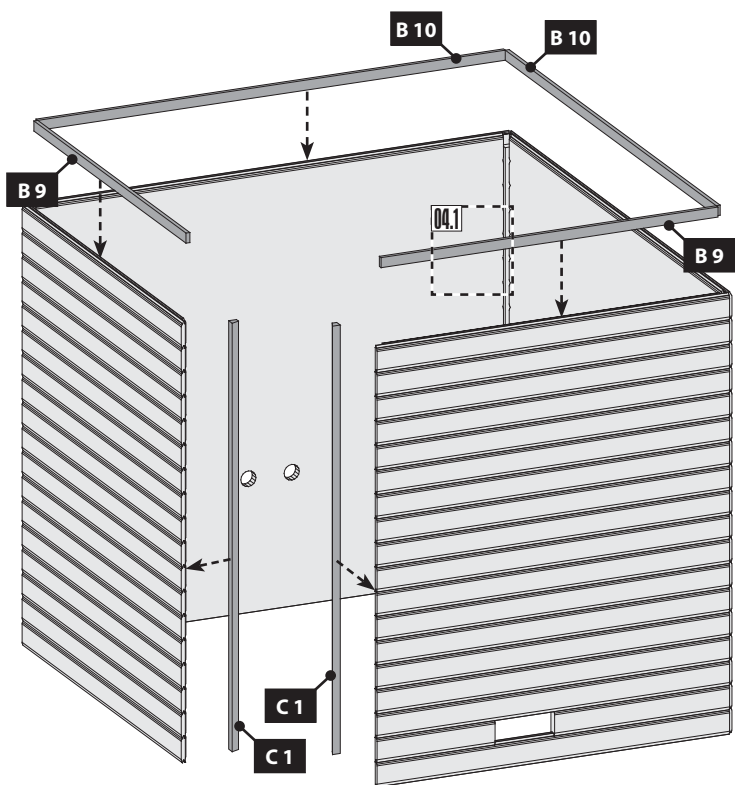

05

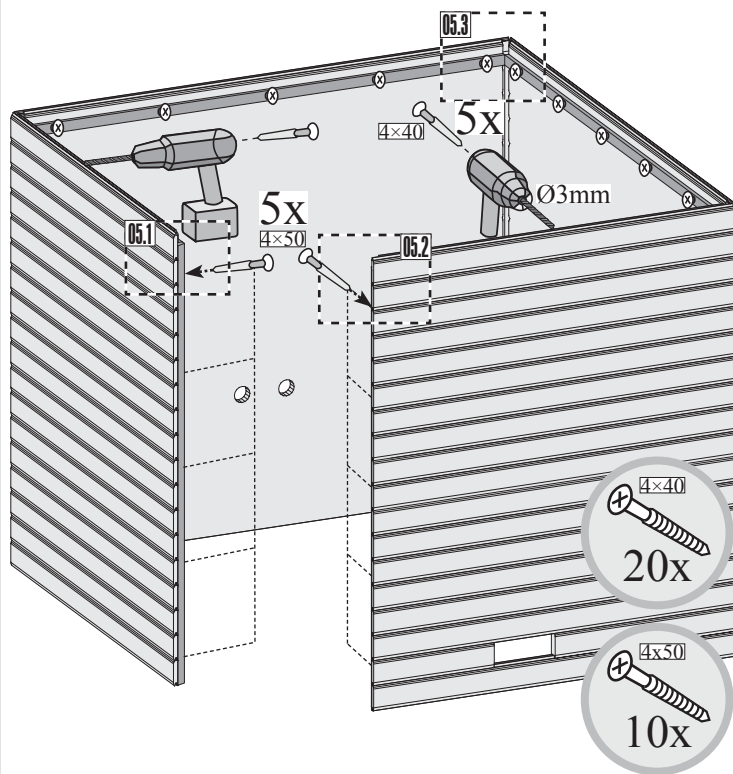
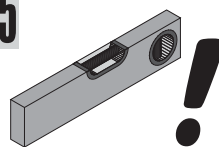

Bündig!
 Affleurement!
 Gelijk!
 Aras!
 Flush!
 Combacia!
 Stejný!

05.1

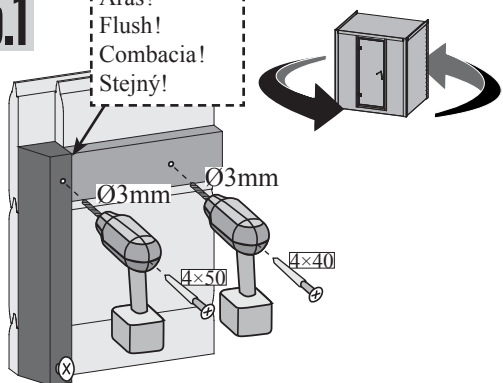

05.2

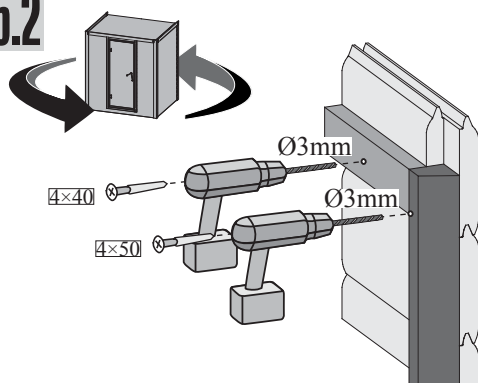

05.3

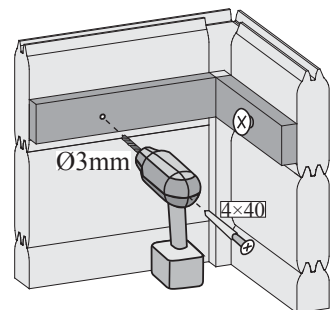

06

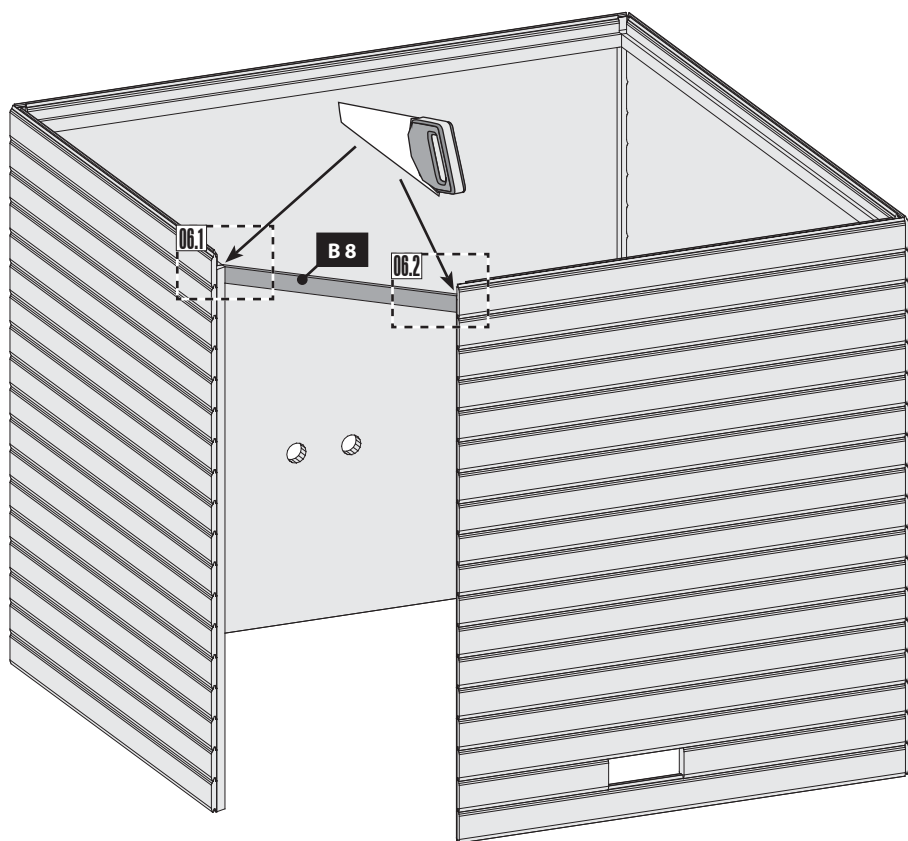

06.1

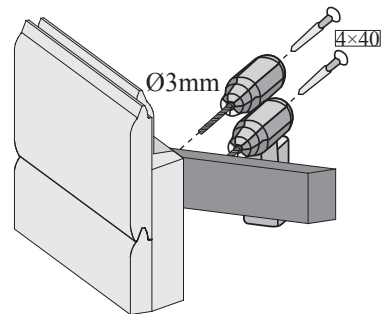

06.2

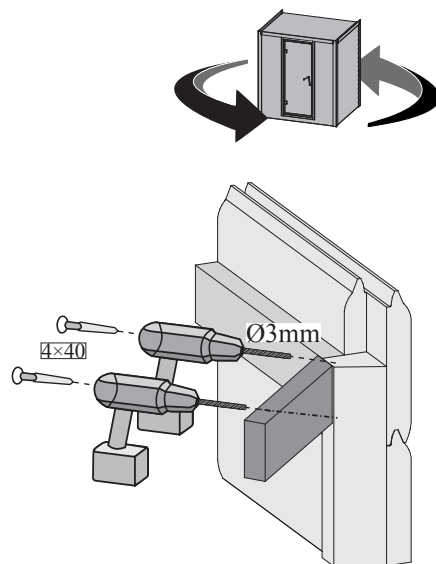

Bündig!
Affleurement!
Gelijk!
Aras!
Flush!
Combacia!
Stejný!

07

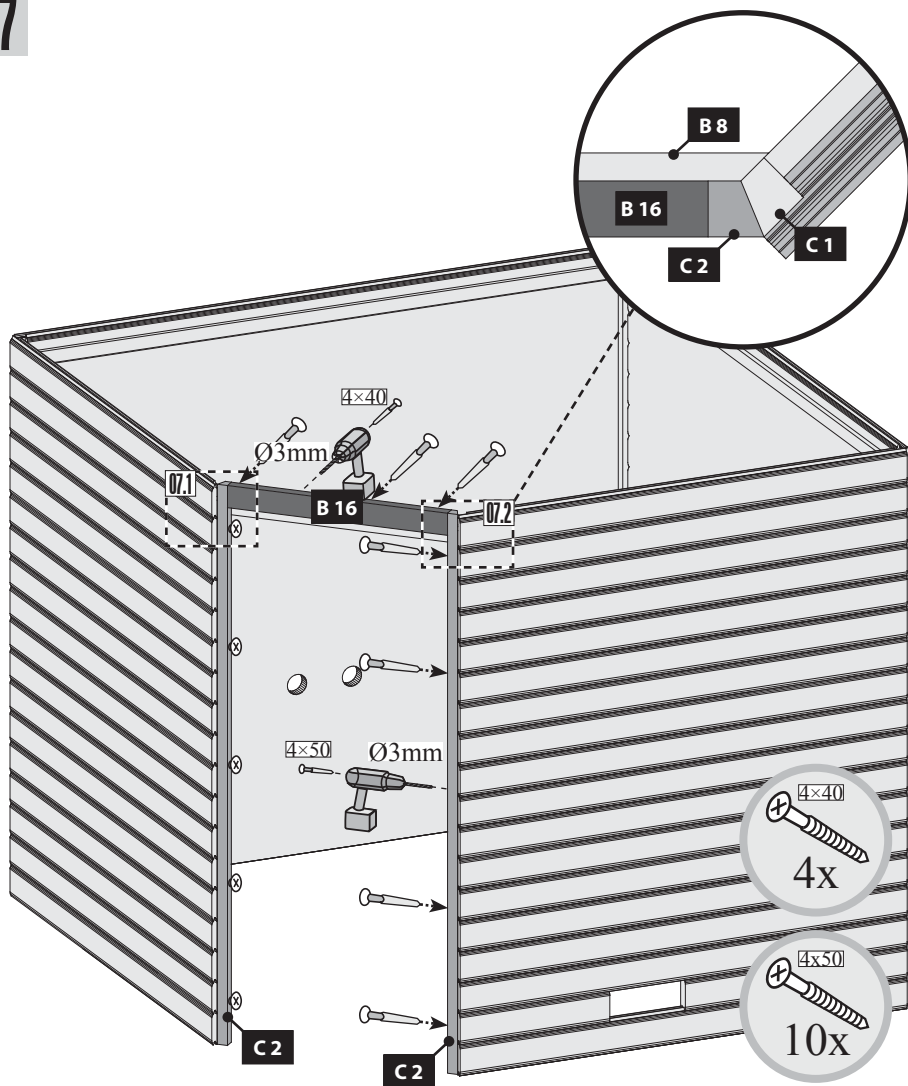

07.1

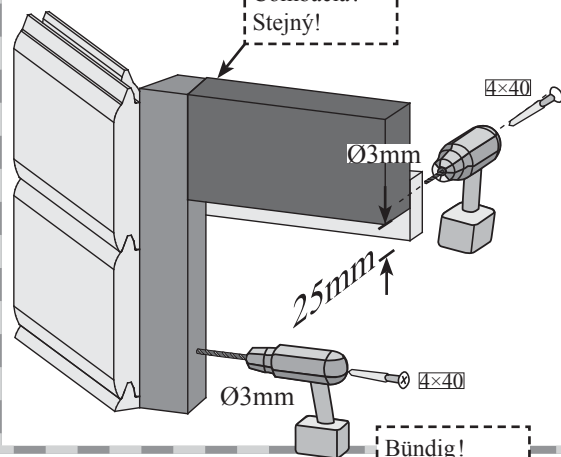

07.2

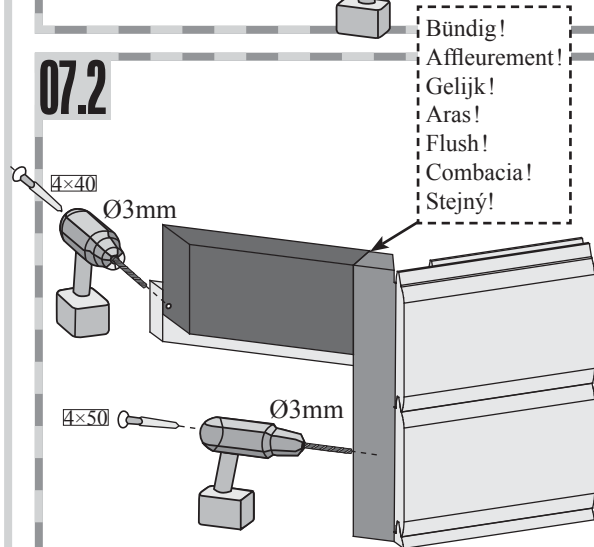



Einbau Saunatür

Sauna deur installatie

Sauna Instalace dveře

Installation de porte Sauna

Instalación de la puerta Sauna

Sauna door installation

Installazione porta Sauna

!!! 01 → 03 !!!

08

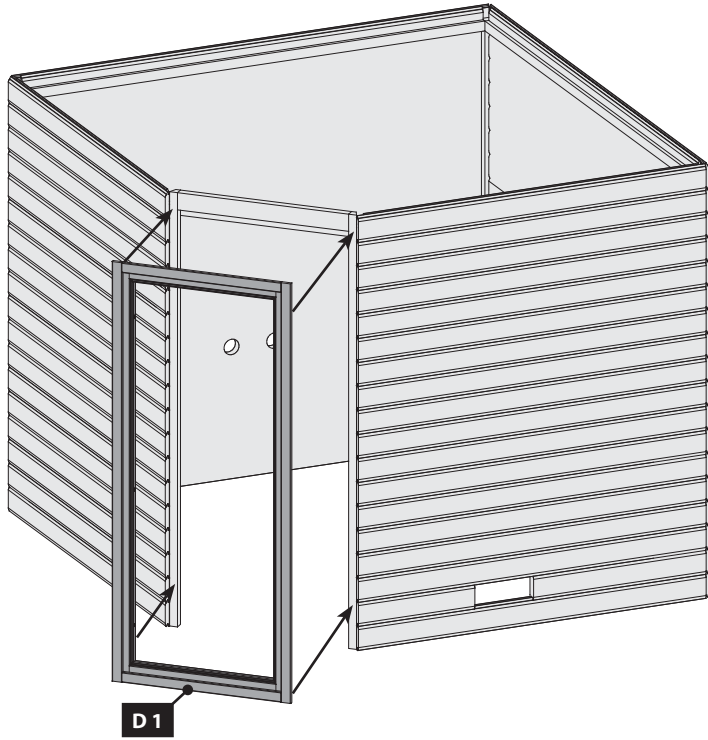

09

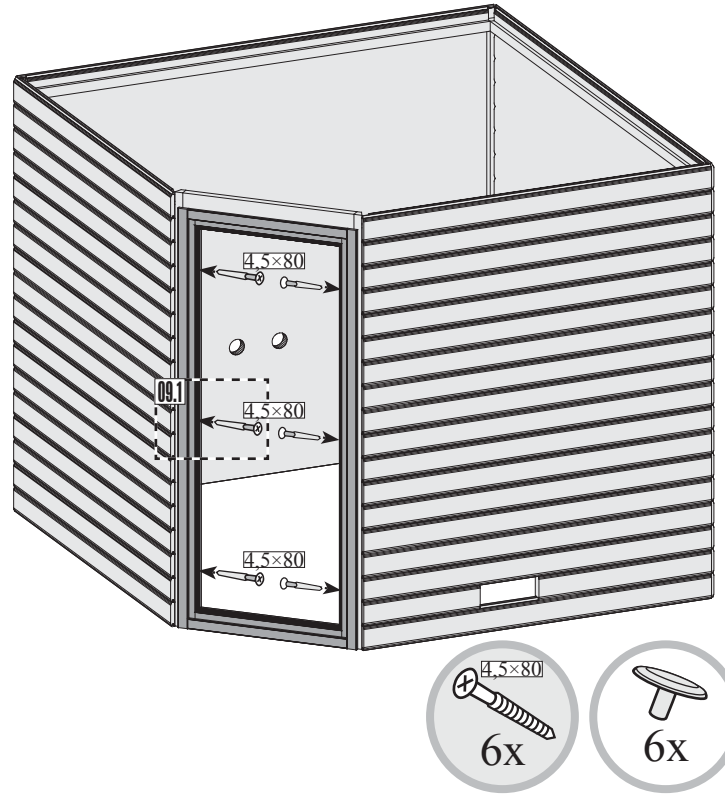

10

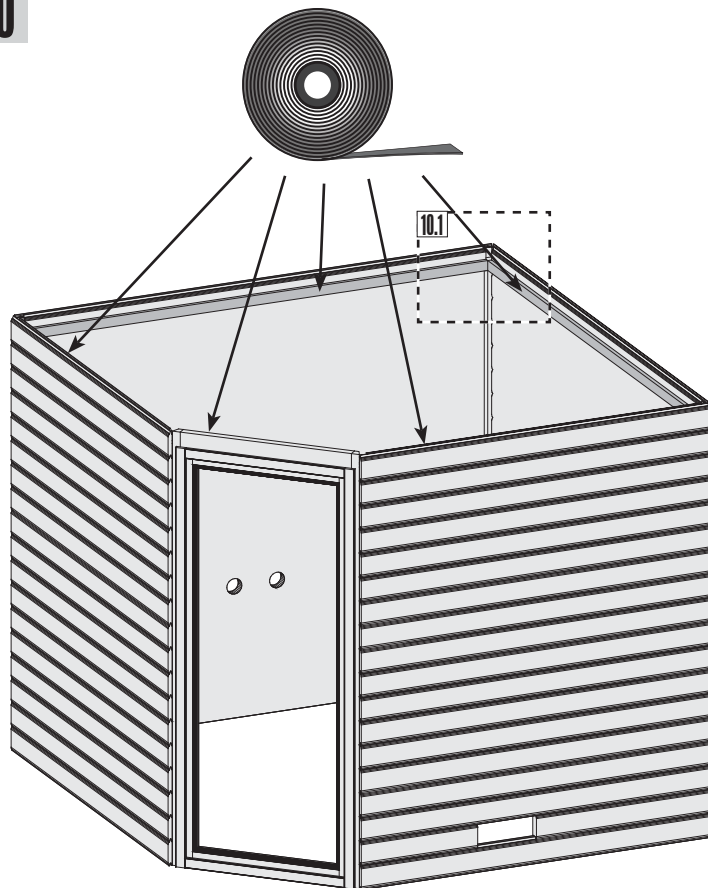

09.1-1

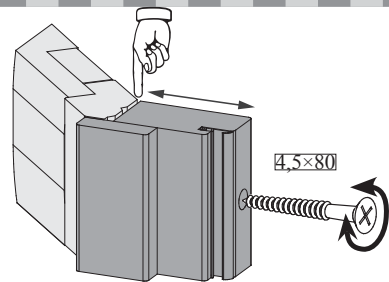

09.1-2

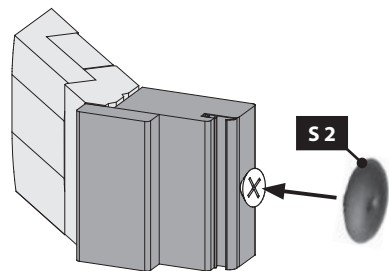

10.1

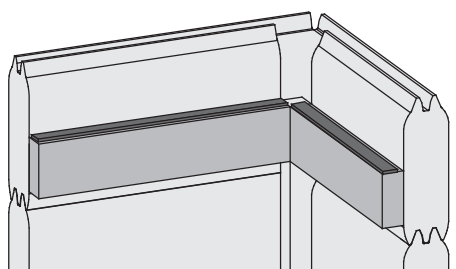

11

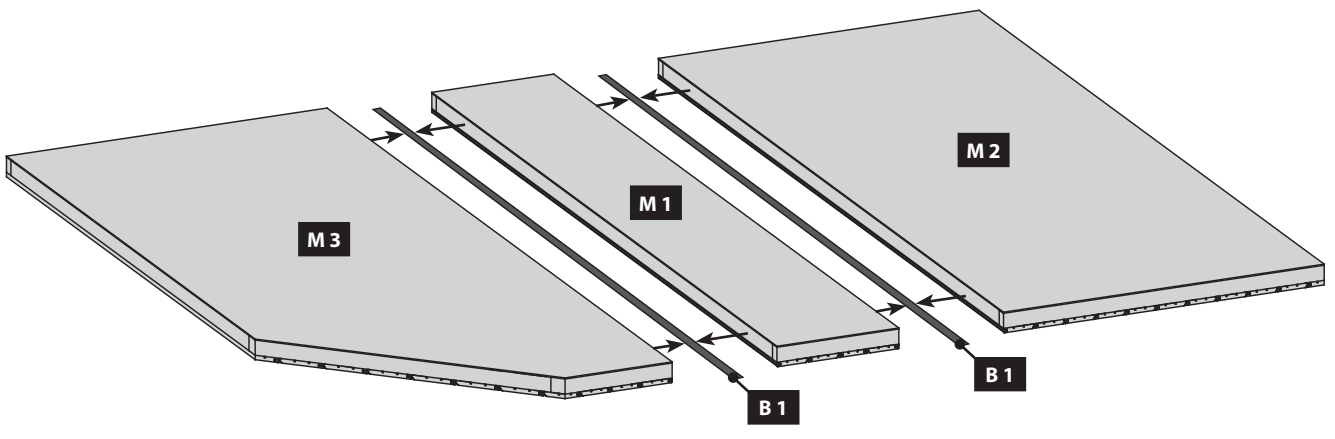

12

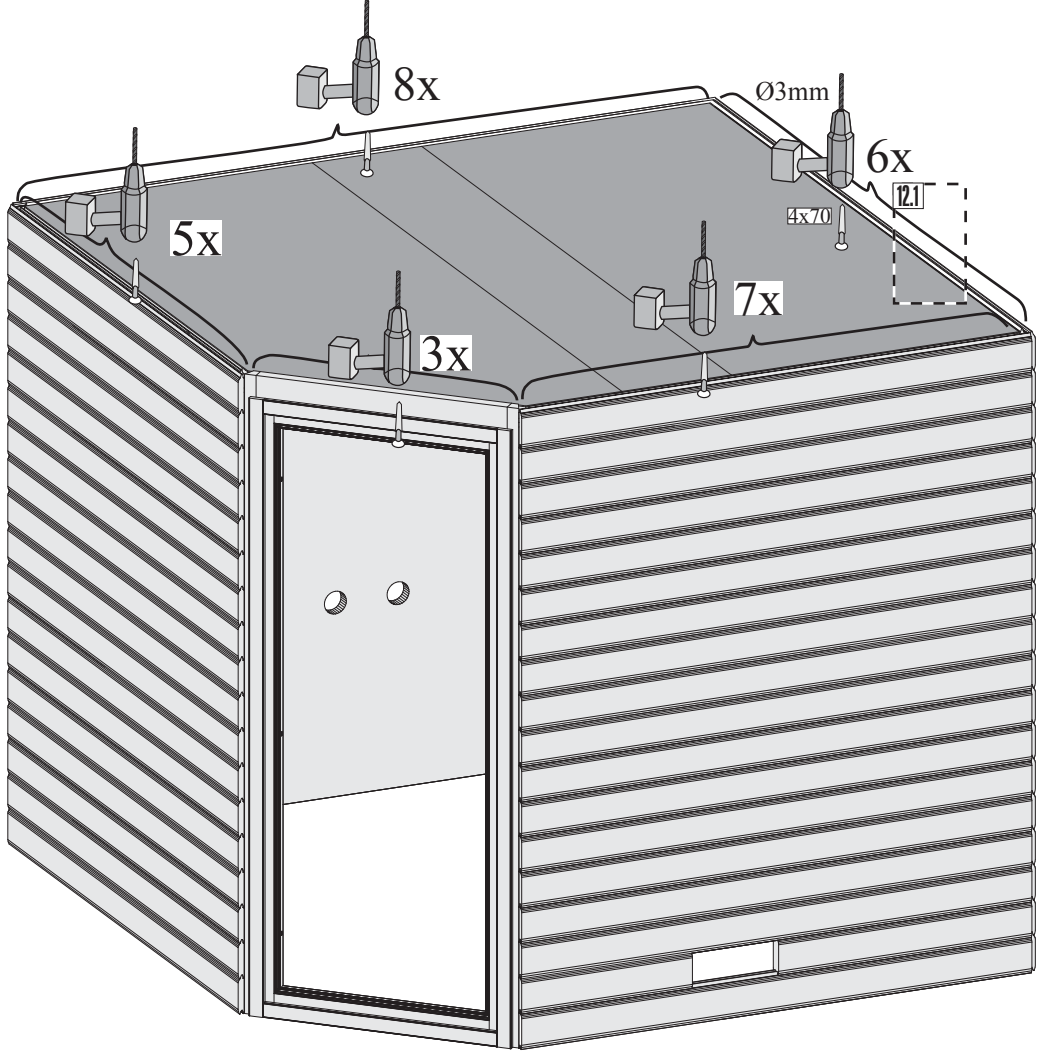

12.1

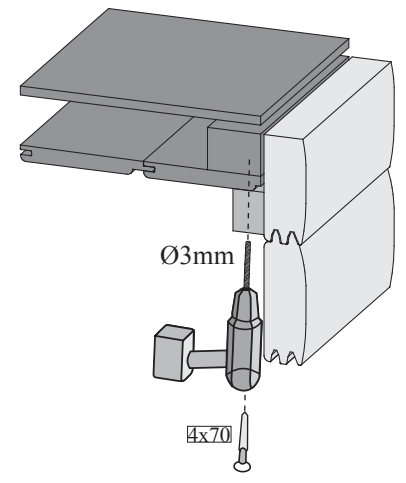

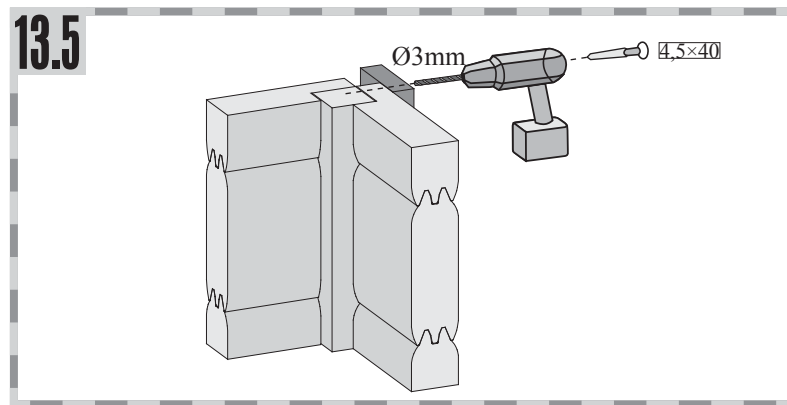
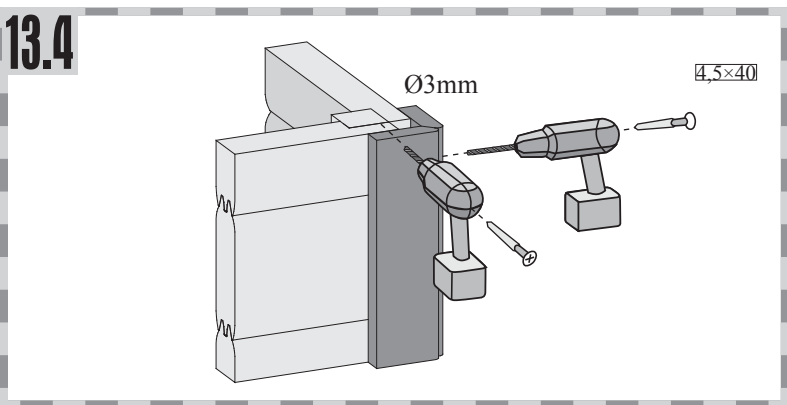
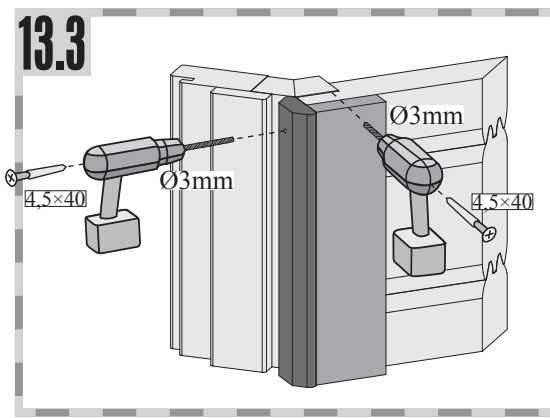
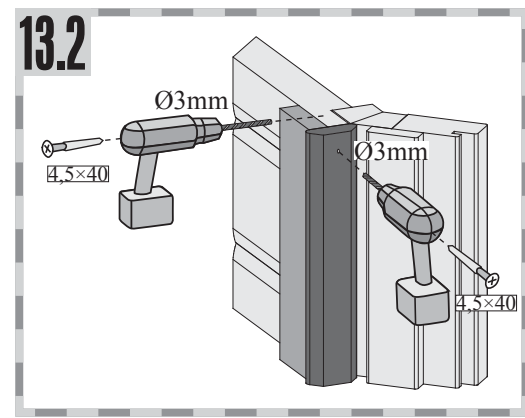
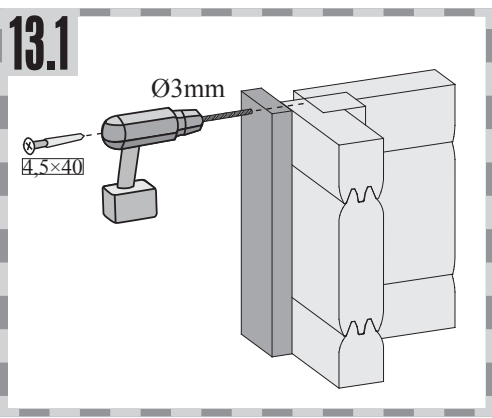
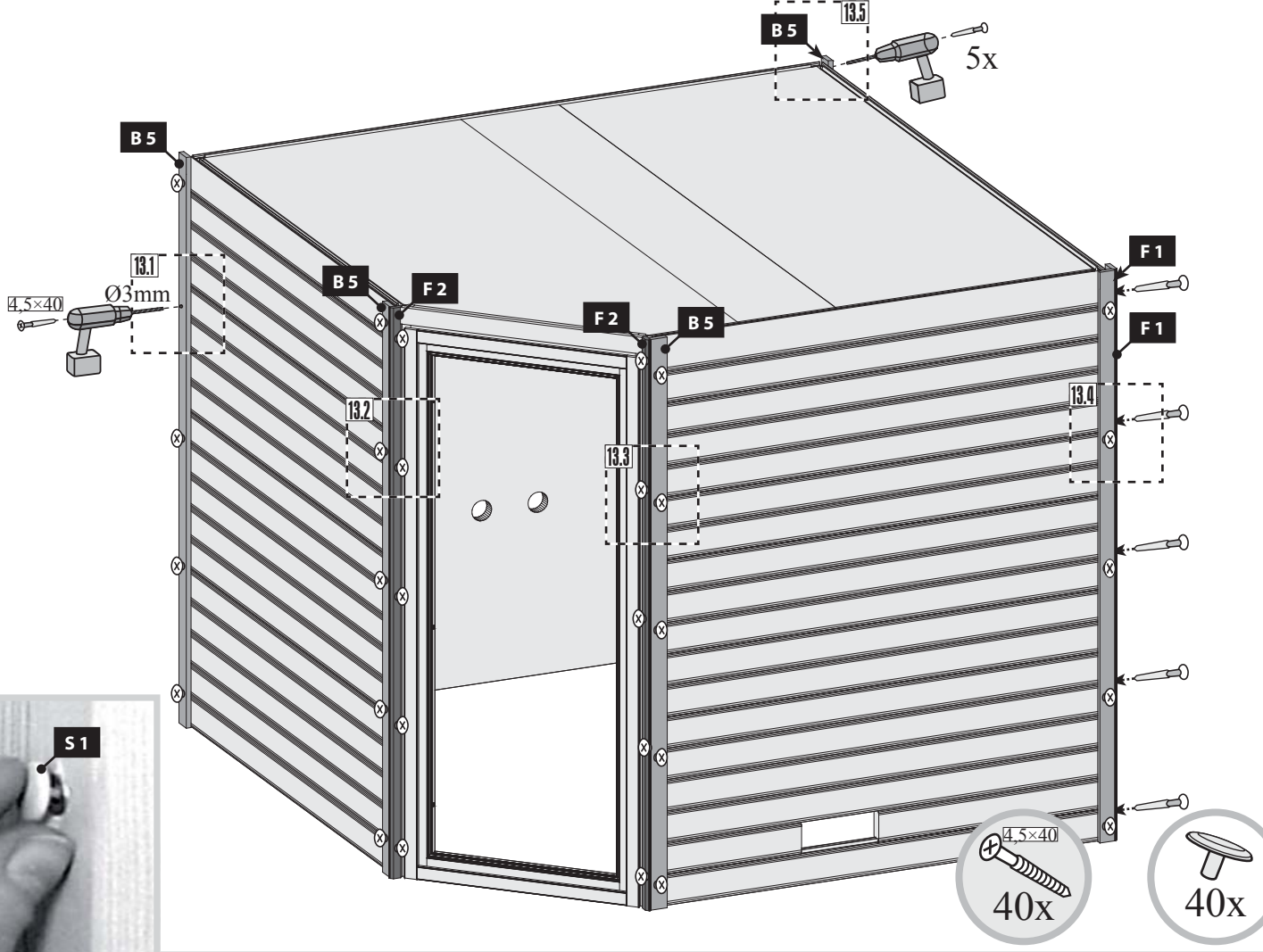

14

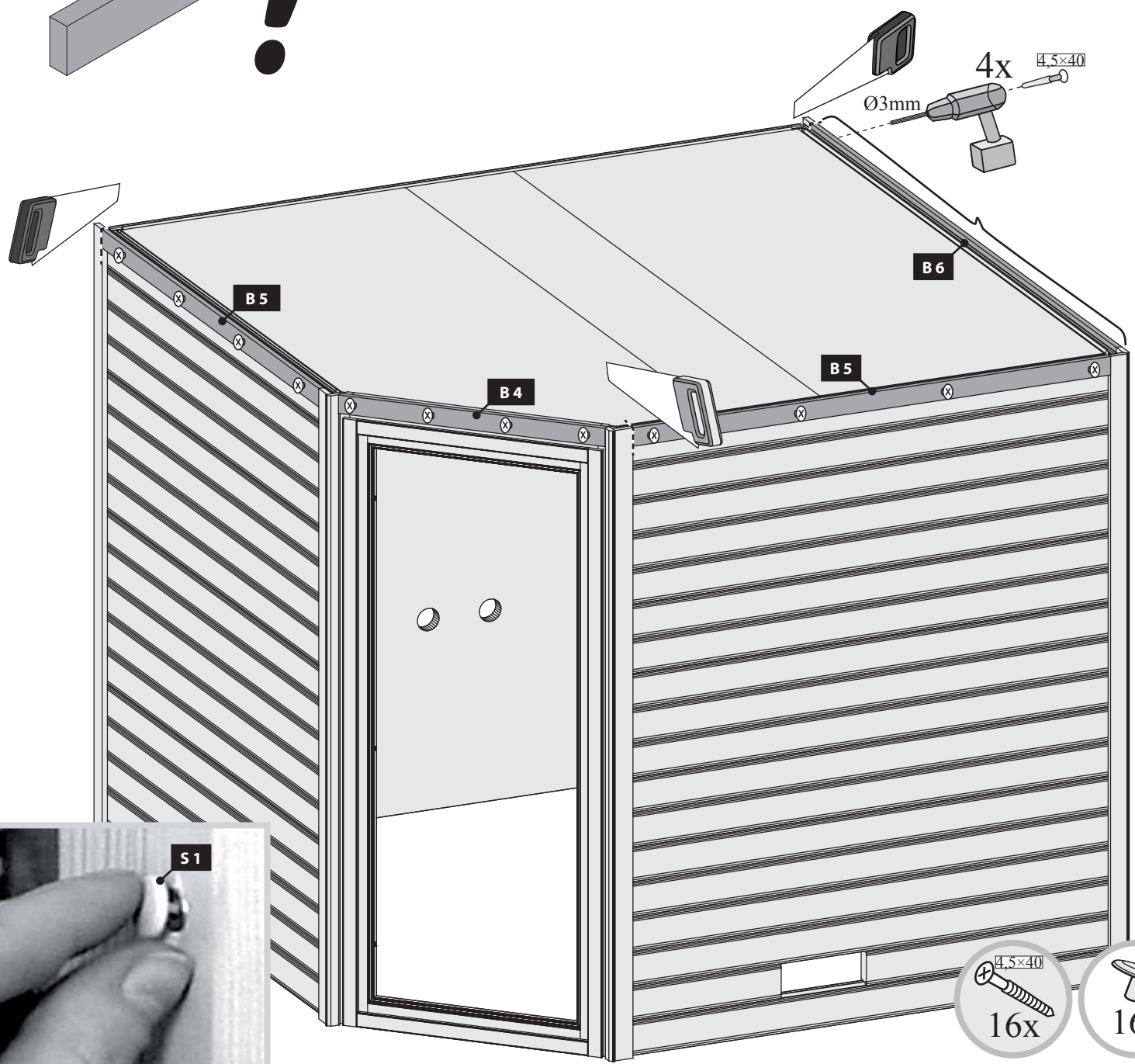
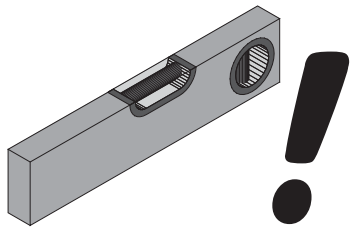

15 2x

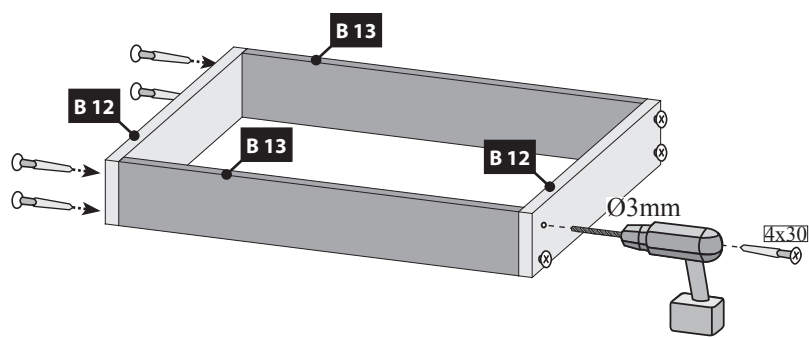

16 a

-  Nur bei 9 kW-Ofen
-  Seulement 9 kW chauffe
-  Only 9 kW heater
-  Slechts 9 kW heater
-  Sólo calentador de 9 kW
-  Solo riscaldamento 9 kW
-  Pouze topné těleso 9 kW

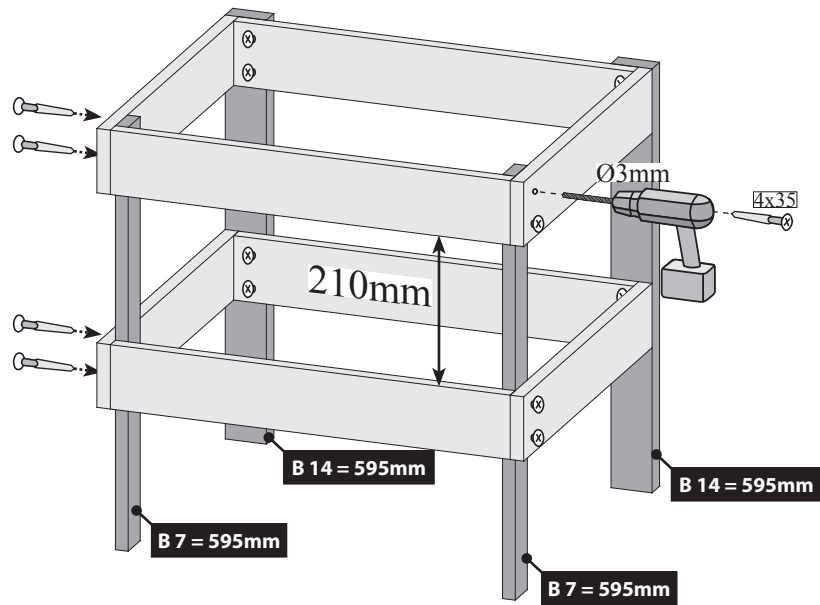
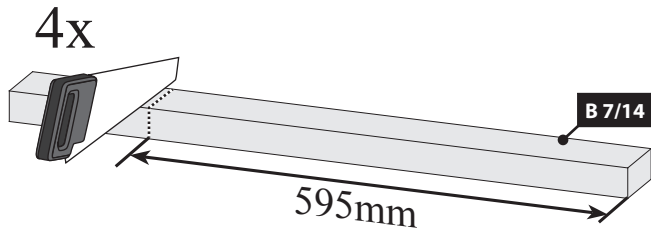

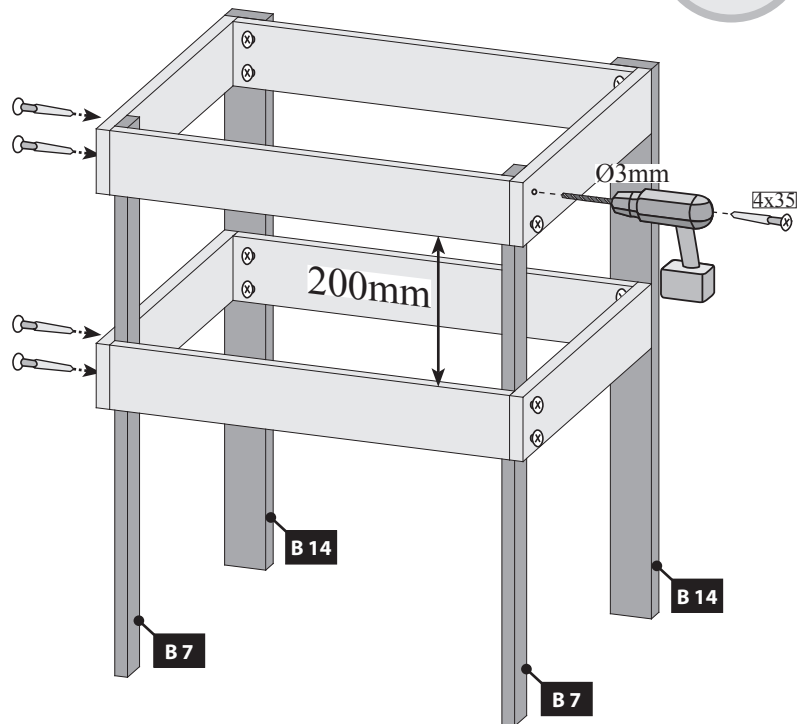

16 b

-  Bei allen anderen Öfen
-  Pour tous les autres fours
-  For all other furnaces
-  Voor alle andere ovens
-  Para todos los otros hornos
-  Per tutti gli altri tipi di forni
-  U všech ostatních pecích

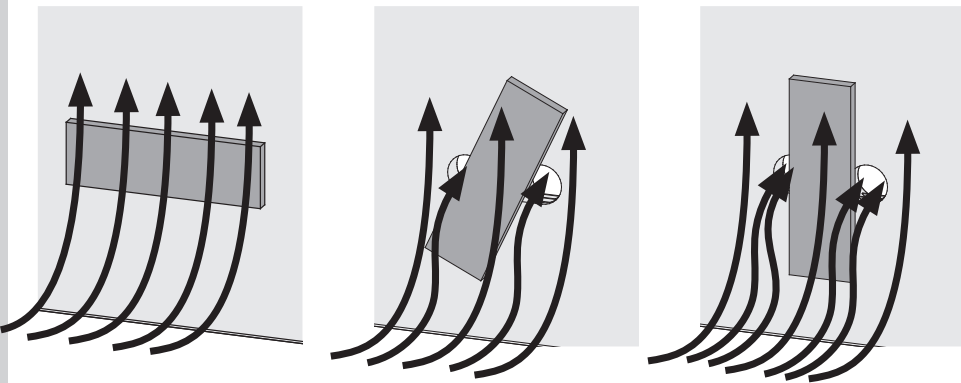
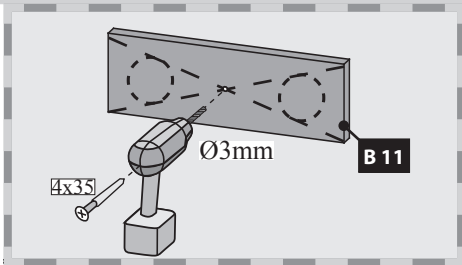
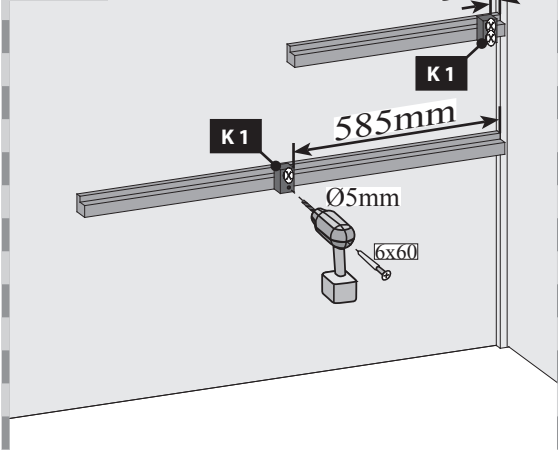
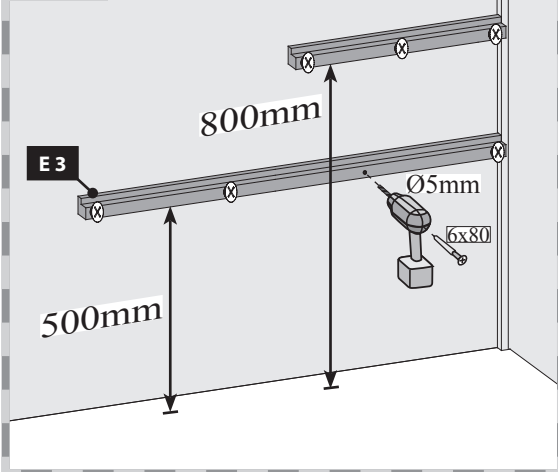
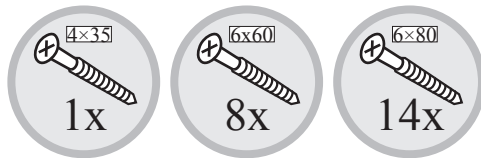
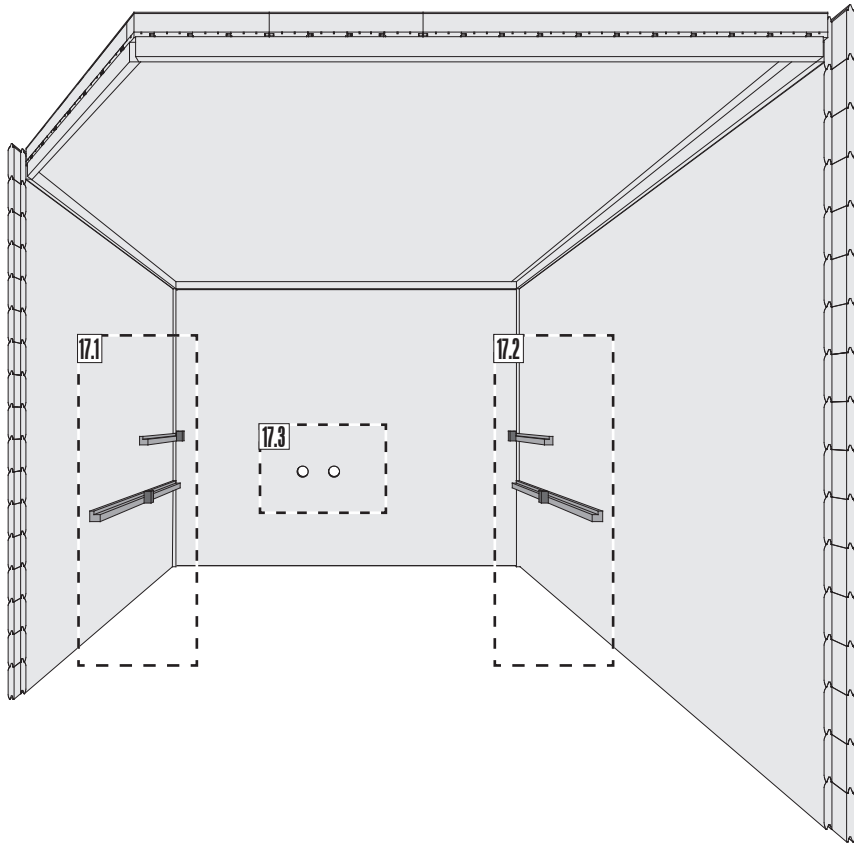





 Hier ist die Funktionsweise des Brettes abgebildet. Regeln Sie damit die Abluft nach Ihren eigenen Wünschen.

 Ceci représente le mode de fonctionnement de la planche. Avec elle, réglez l'écoulement de l'air selon vos désirs.

 This figure shows the functional principle of the board. Regulate the exhaust air according to your own wishes.

 Hier is de werking van het plankje afgebeeld. Regel daarmee de luchtafvoer naar eigen wens.

 Aquí está representada la forma de funcionamiento de la tabla. Regule con ello el aire de salida según sus propios deseos.

 Viene illustrato il principio di funzionamento della tavoletta di regolazione della ventilazione. Con essa si può regolare a piacere la ventilazione.

 Zde je zobrazená funkce desky. Regulujte s ní odsávací vzduch dle Vašeho přání.

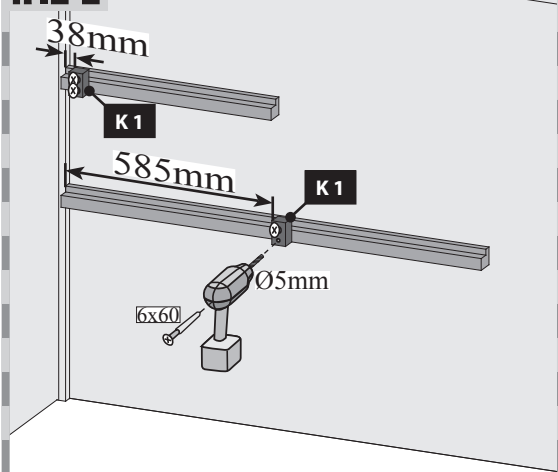
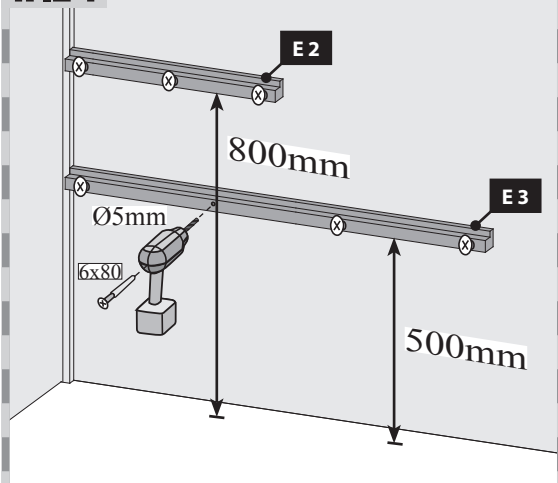

18

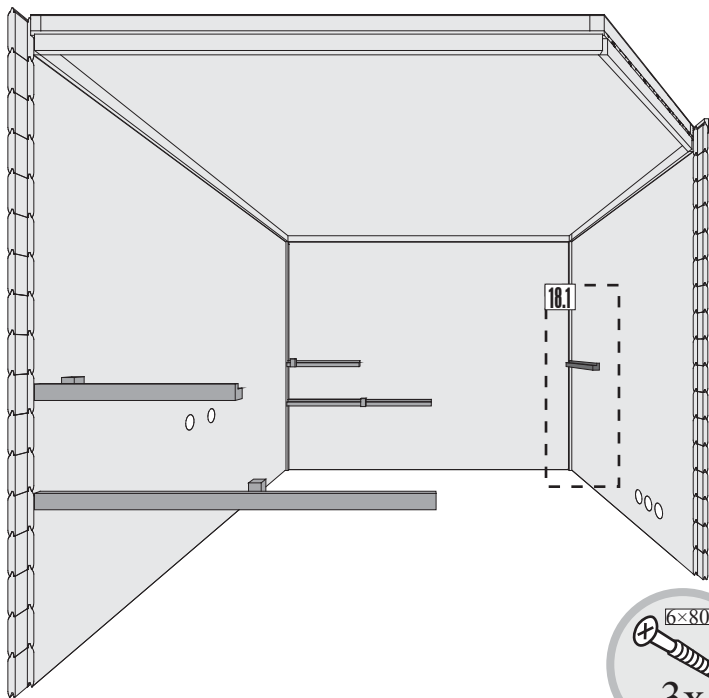
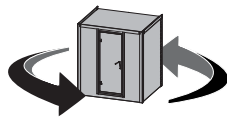

18.1-2

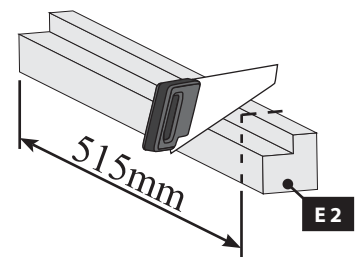

18.1-2

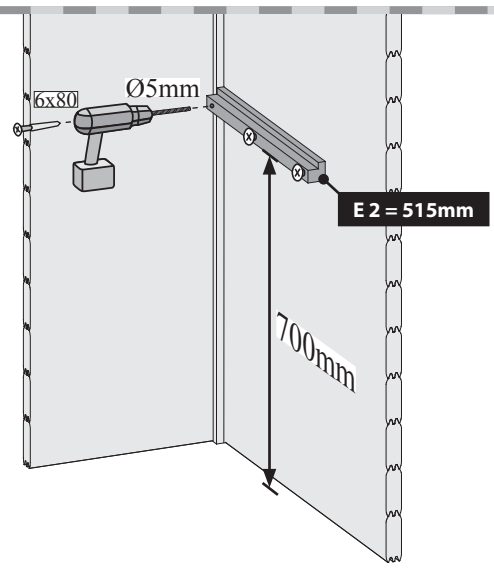

19

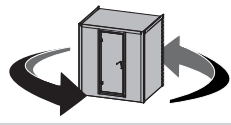
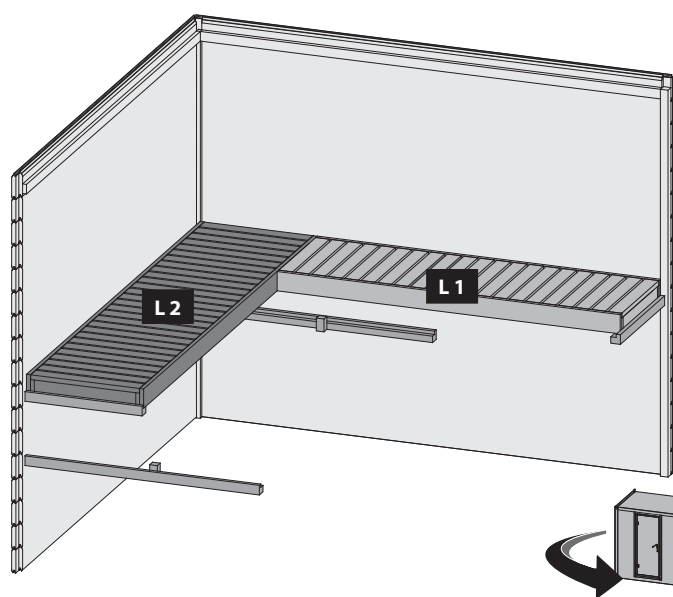

21

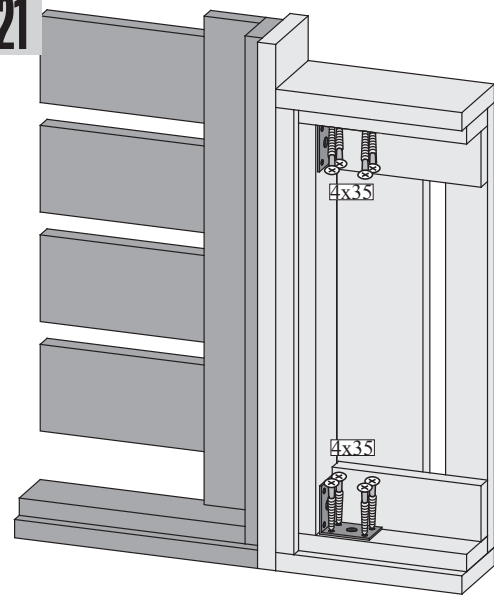

20

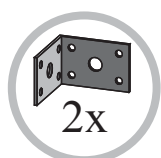
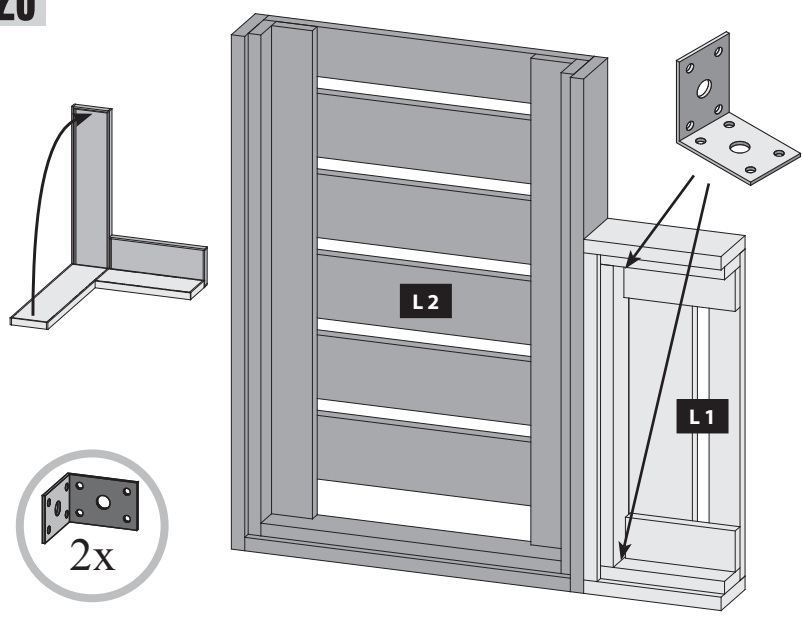

22

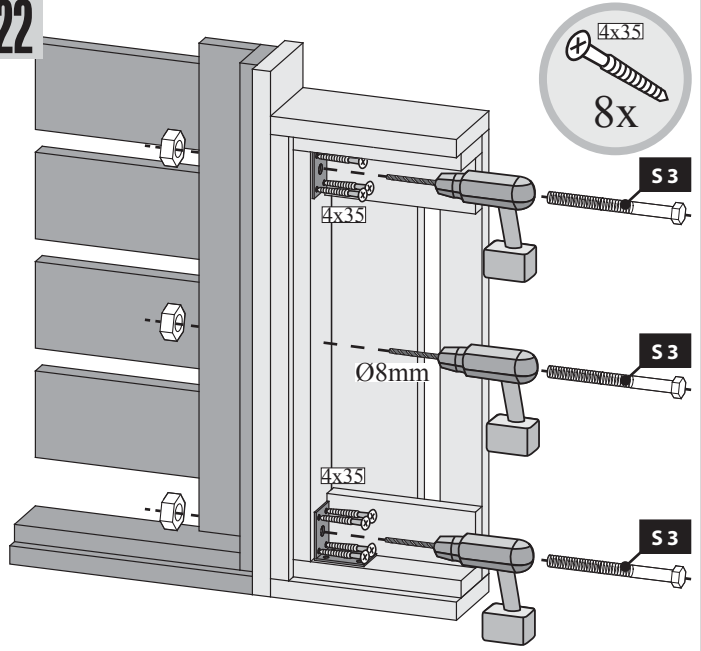

S3

S3

S3

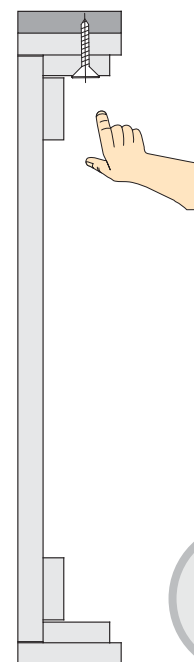
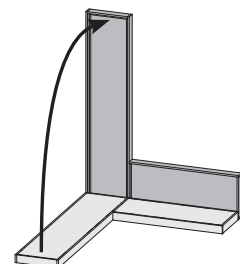
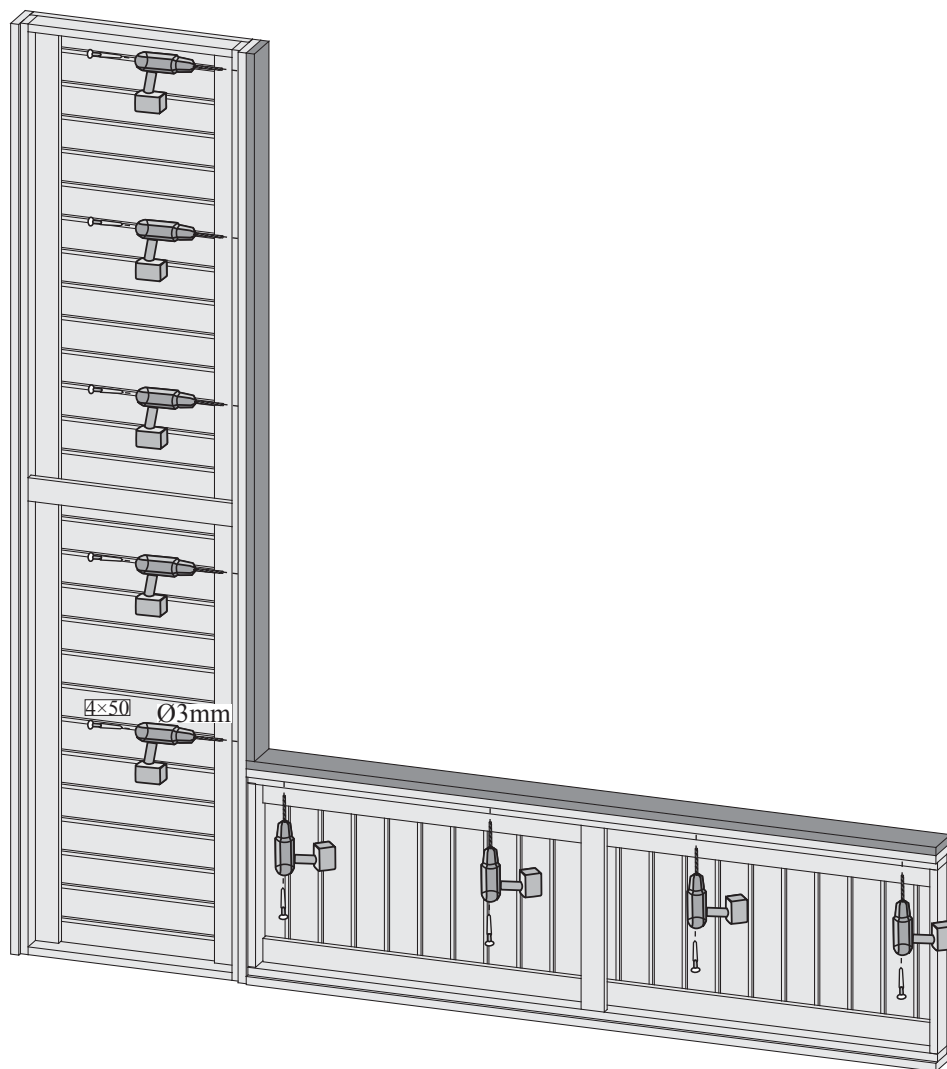
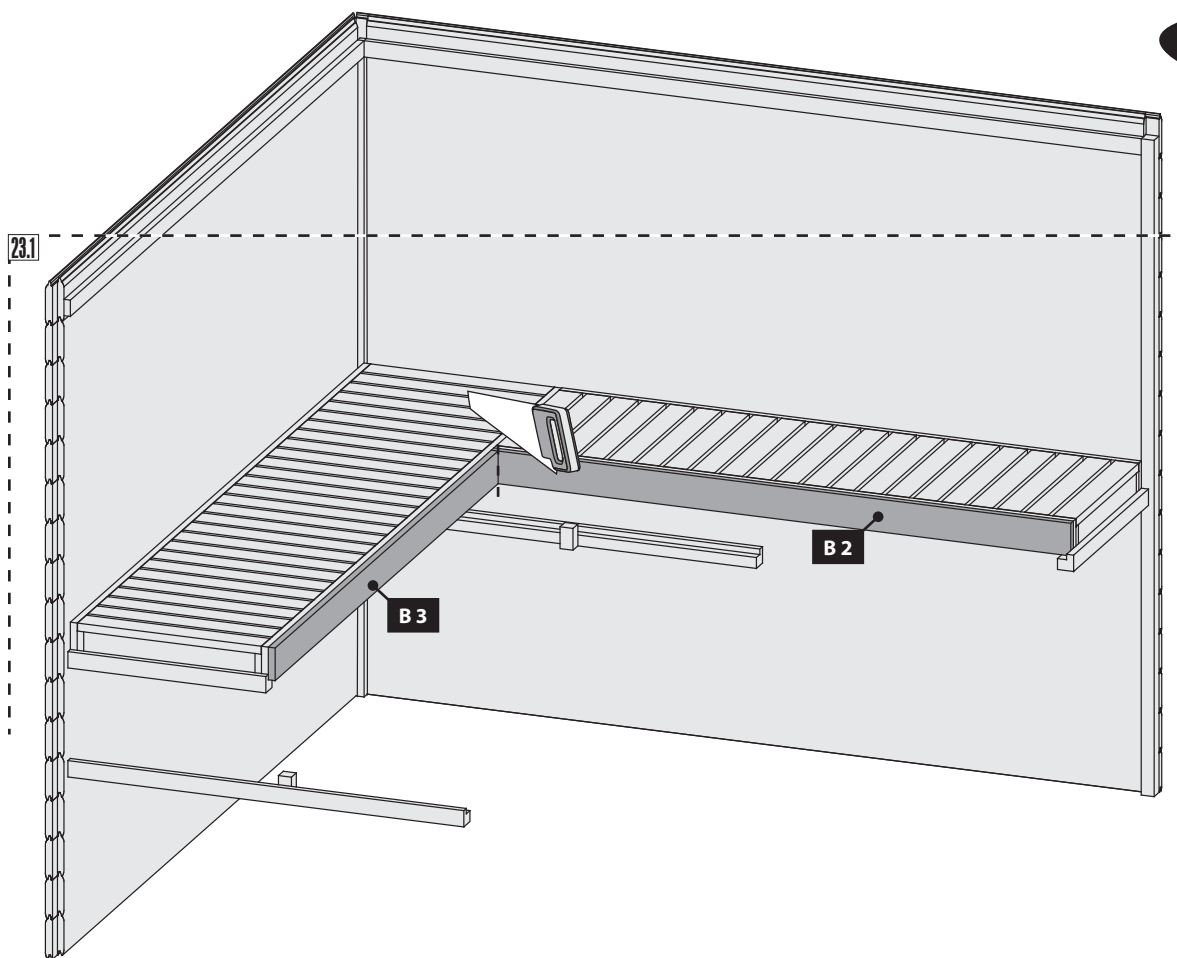
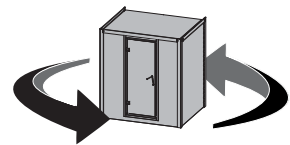

24

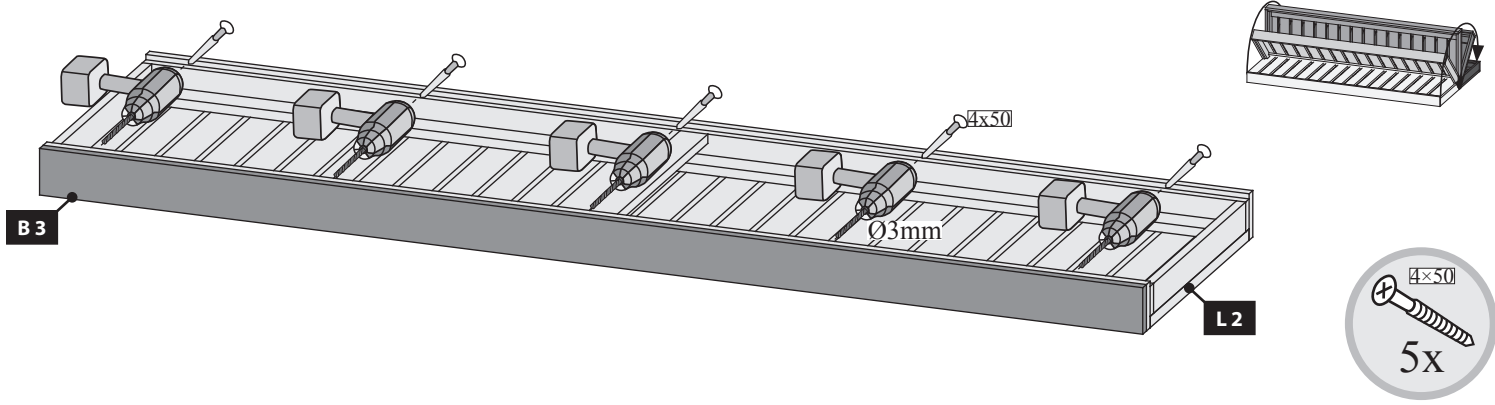

25

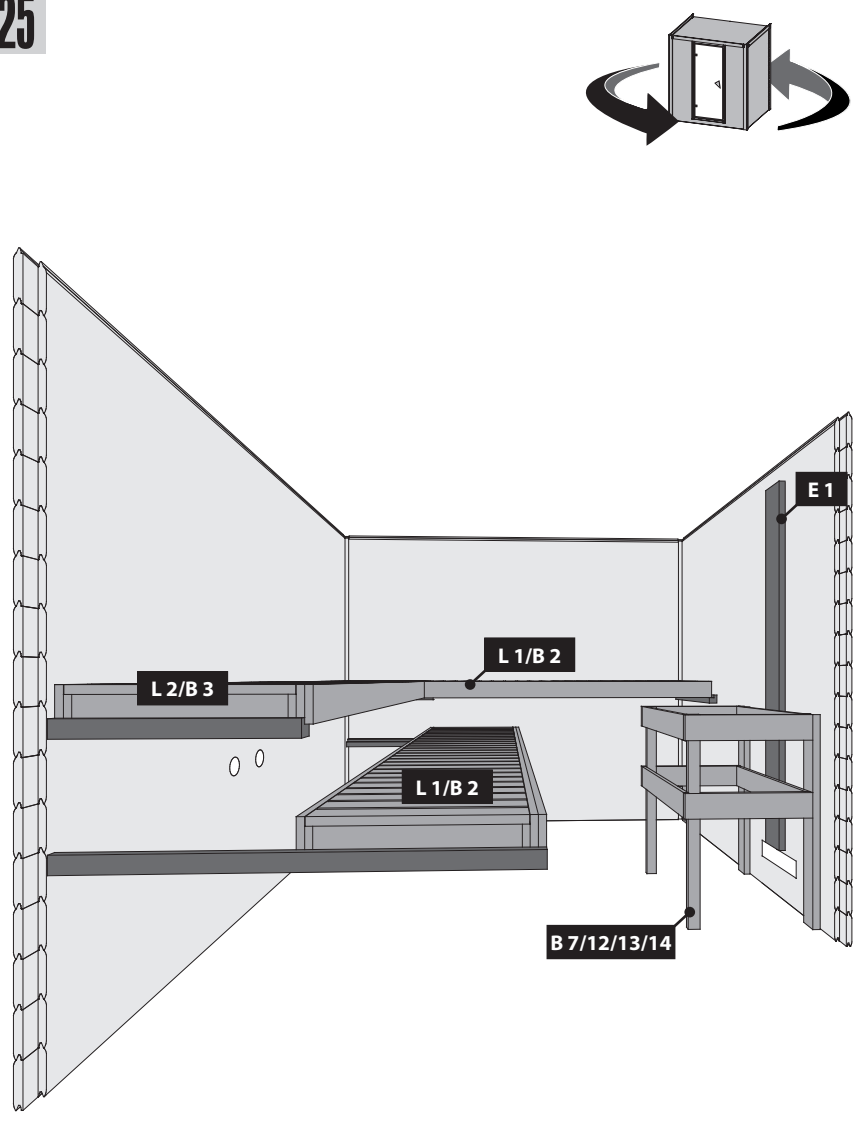

26

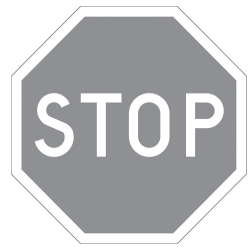
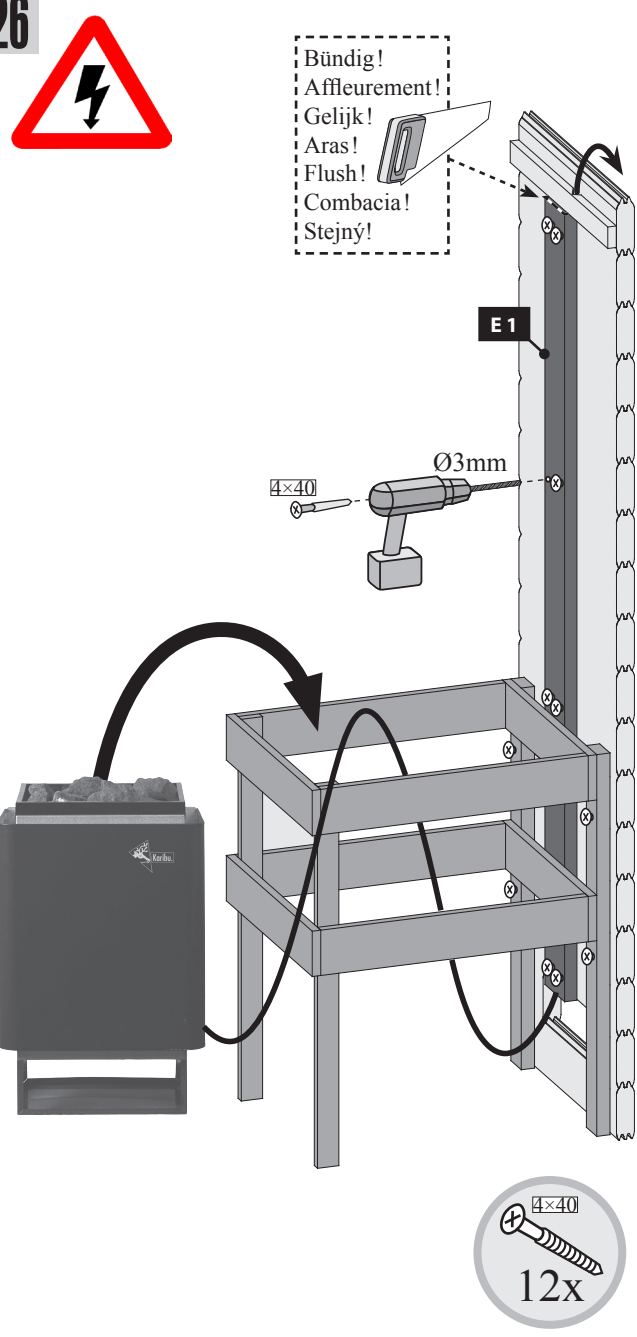

- Einbau Saunatür**
- Sauna deur installatie**
- Sauna Instalace dveře**
- Sauna door installation**
- Instalación de la puerta Sauna**
- Installation de porte Sauna**
- Installazione porta Sauna**

!!!
04
→
...
!!!