

80507

**Aufbauanleitung****notice de montage****Building Instructions****montagehandleiding****Instrucciones de construcción****Istruzioni per il montaggio****Montážní návod****Service-Hotline: +49 421 38693 33**

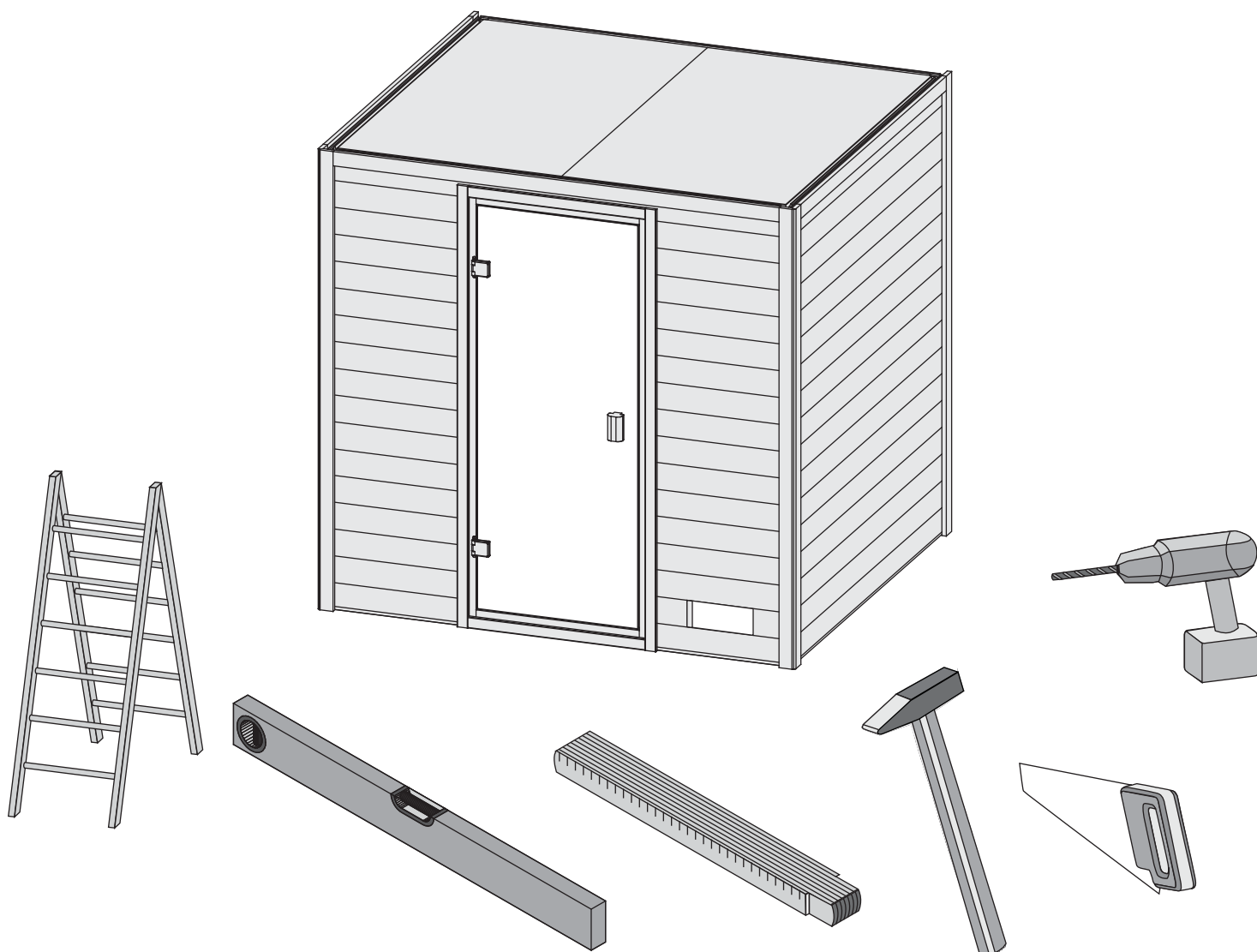

Vergleichen Sie zuerst die Material-liste mit Ihrem Paketinhalt! Bitte haben Sie Verständnis, dass Beanstandungen nur im nicht aufgebauten Zustand bearbeitet werden können!



En primer lugar, compare la lista de material con el contenido del paquete. Rogamos entienda que las reclamaciones sólo pueden ser tramitadas antes de montar el objeto!



Nejprve překontrolujte obsah balení podle materiálového listu! Mějte pochopení pro to, že případnou reklamaci se můžeme zabývat pouze tehdy, když díly nebudou smontované! Za pomoci tohoto seznamu můžete jednotlivé díly přiřadit k montážnímu návodu.



Vergelijk eerst de lijst van materialen met de inhoud van uw pakket! Reclamaties kunnen alleen in behandeling worden genomen zolang de onderdelen nog niet zijn gemonteerd!



First compare the list of materials with your package contents! Please understand that complaints can be processed in the non-built status only!



Commencez par comparer la liste du matériel avec le contenu de votre paquet! Sachez que nous traitons uniquement les réclamations concernant le matériel à l'état non monté!



Confrontate questa distinta materiali prima con il contenuto del pacchetto! Vi preghiamo di comprendere che eventuali reclami possono essere accolti solo prima del montaggio!

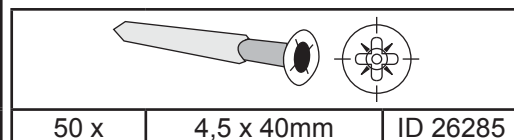
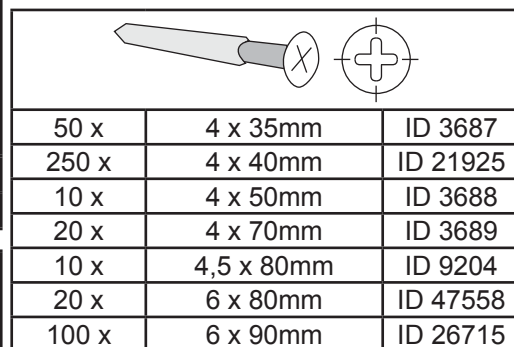
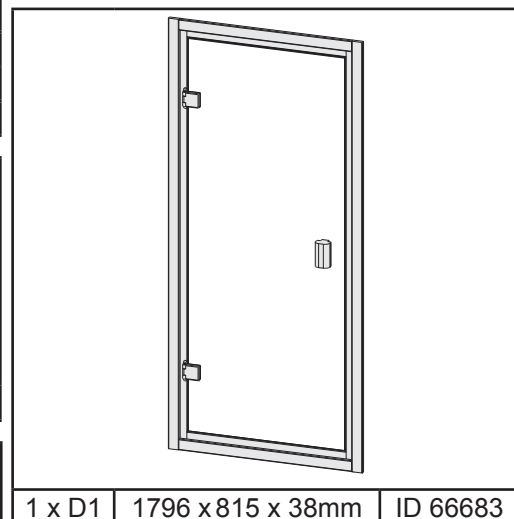
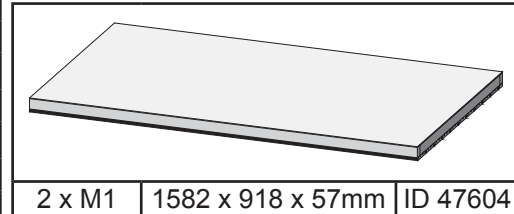
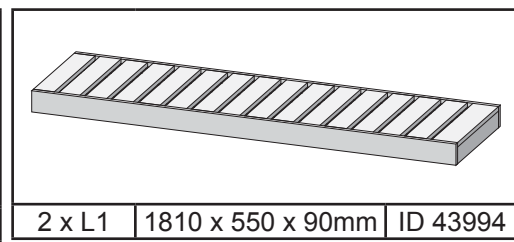
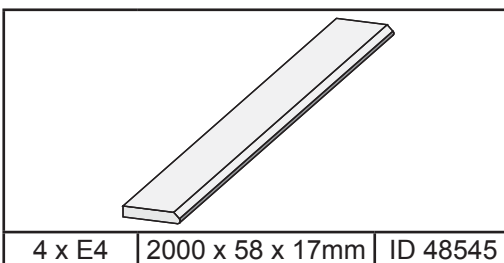
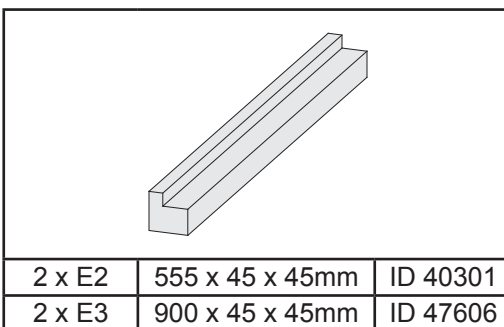
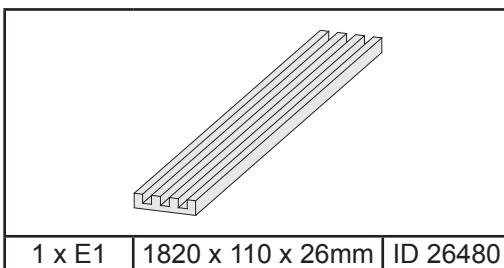
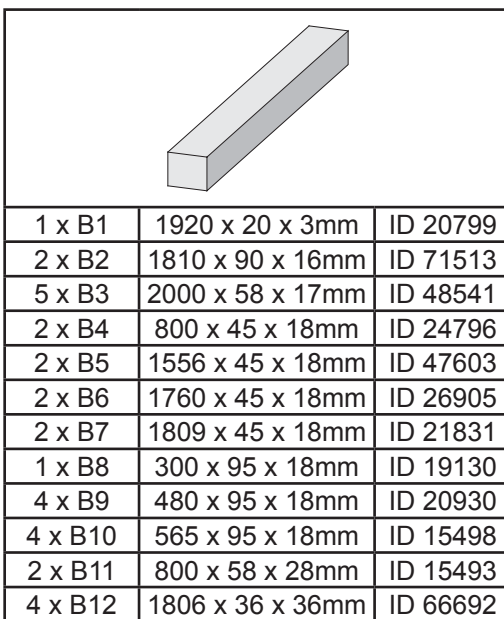
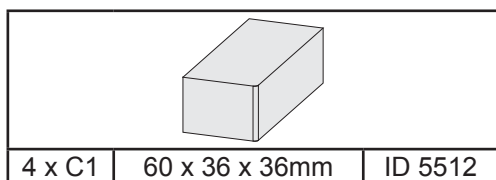
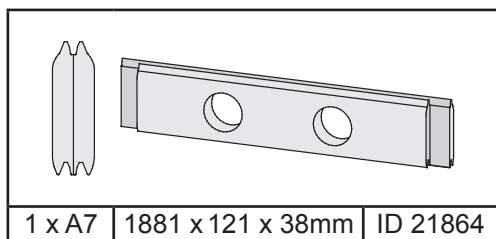
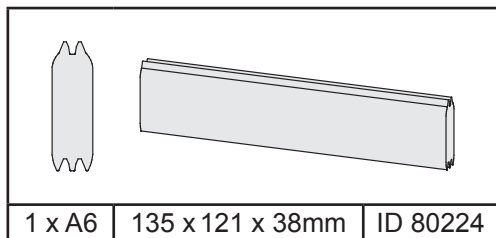
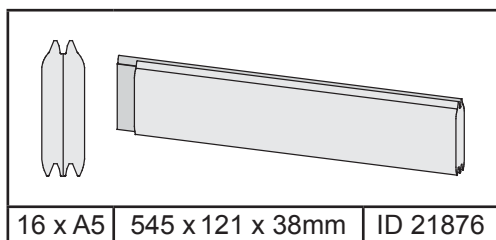
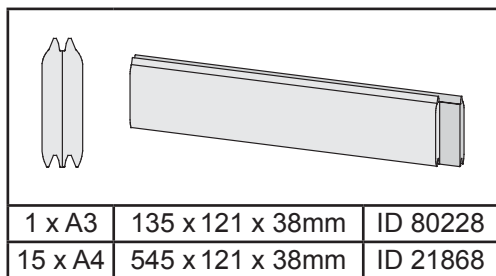
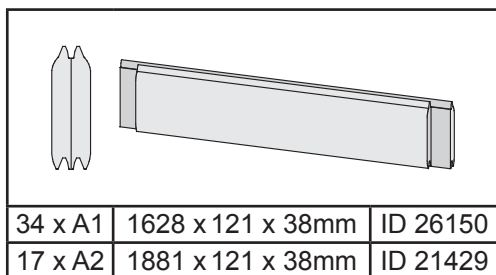
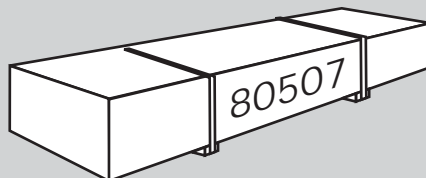

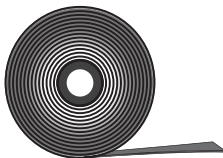
10m		ID 14025
-----	--	----------

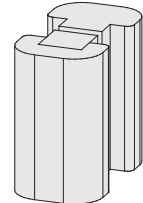
1 x		ID 26183
-----	--	----------

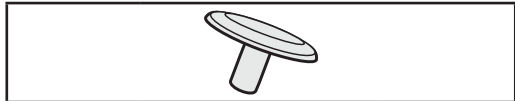

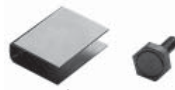
2 x		ID 26496
-----	---	----------

50 x S1	4 x 30mm	ID 26116
6 x S2	12 x 18mm	ID 46403

 Draufsicht

 vue de dessus

 pŕodorys

 bovenaanzicht

 vista desde arriba



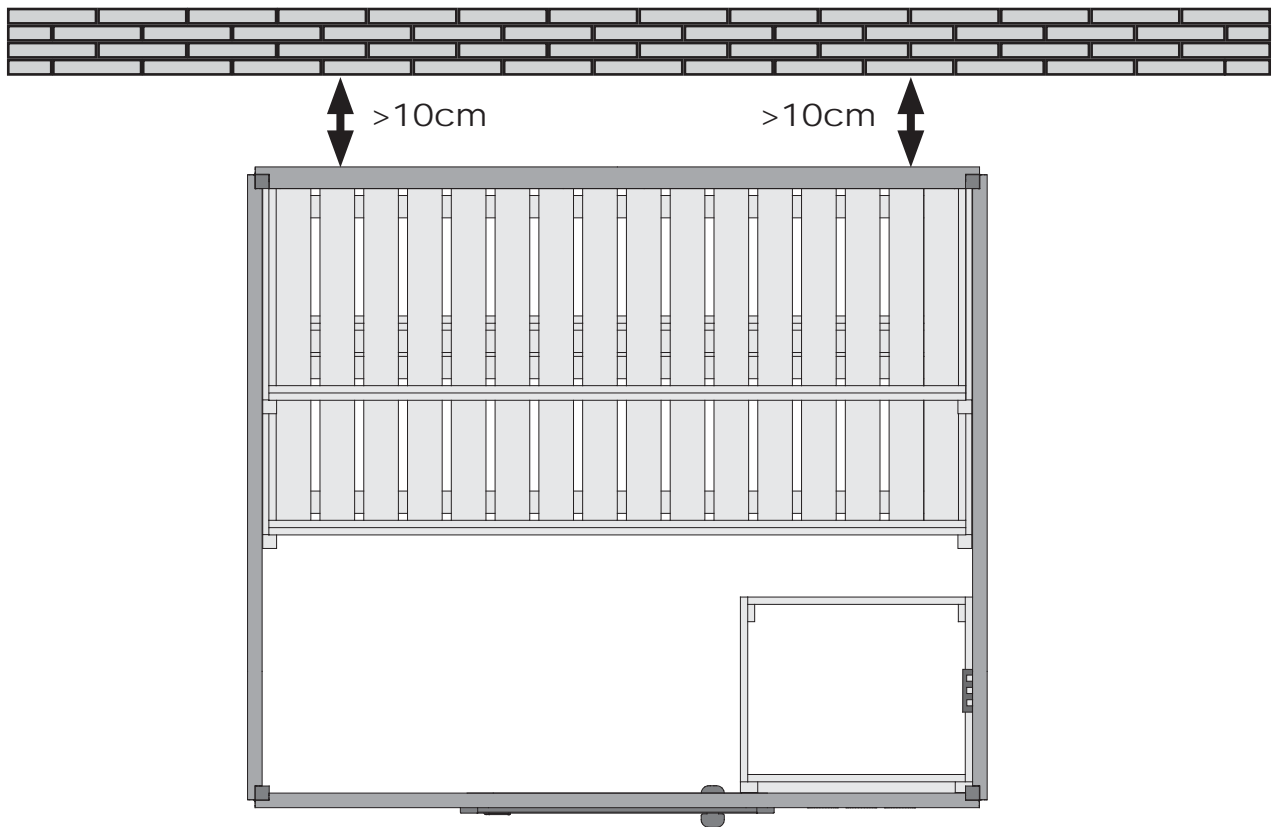

 Top view

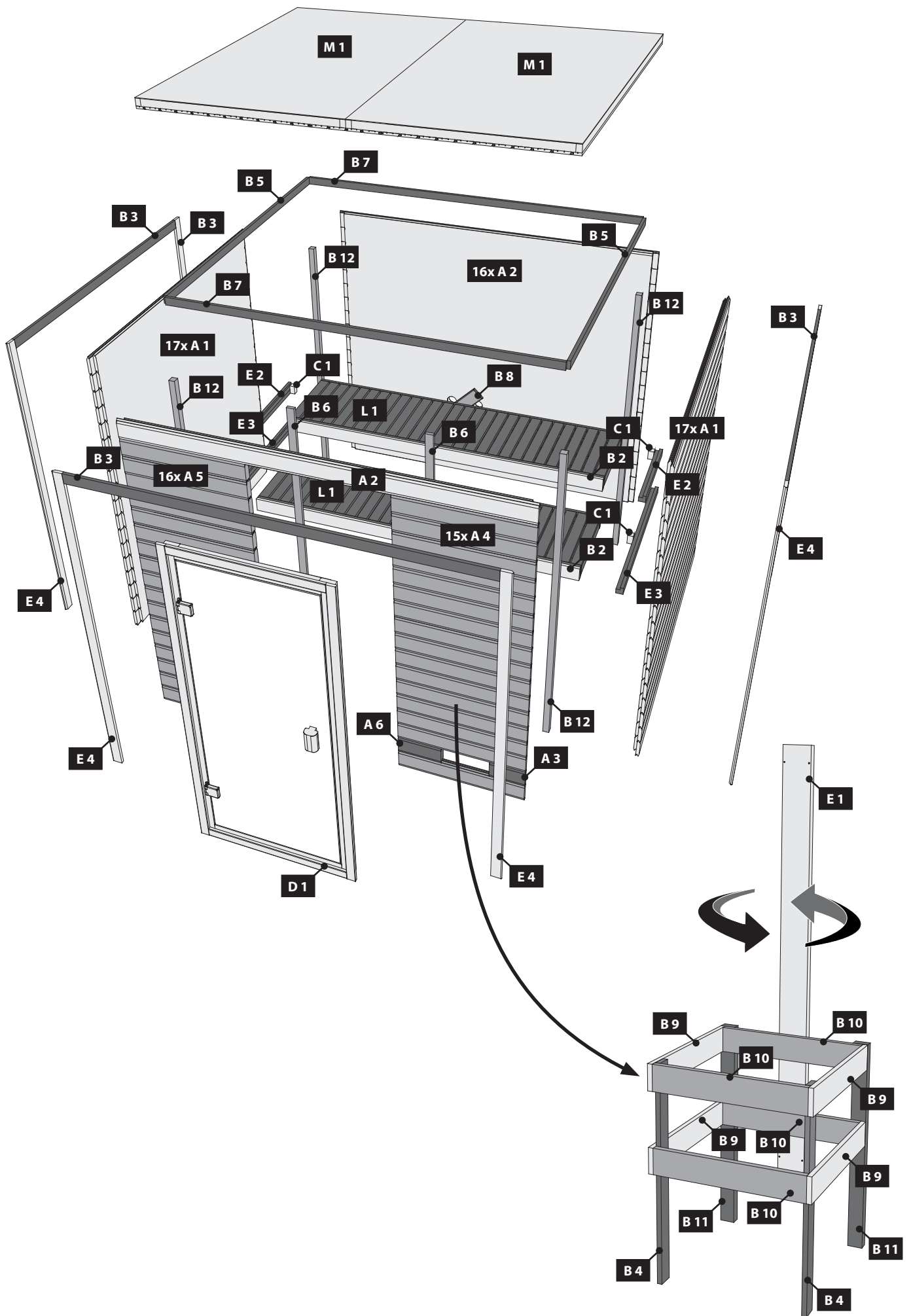

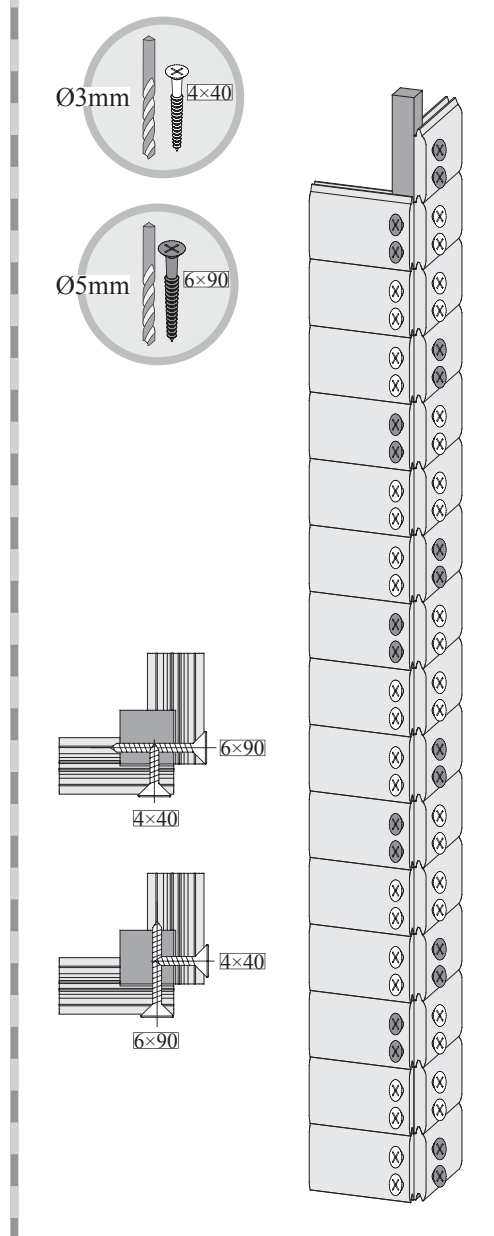
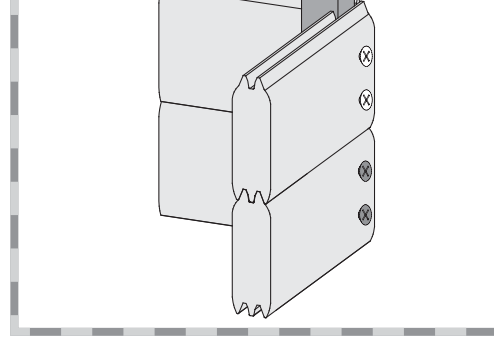
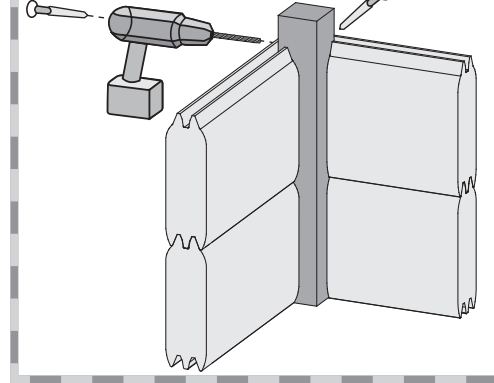
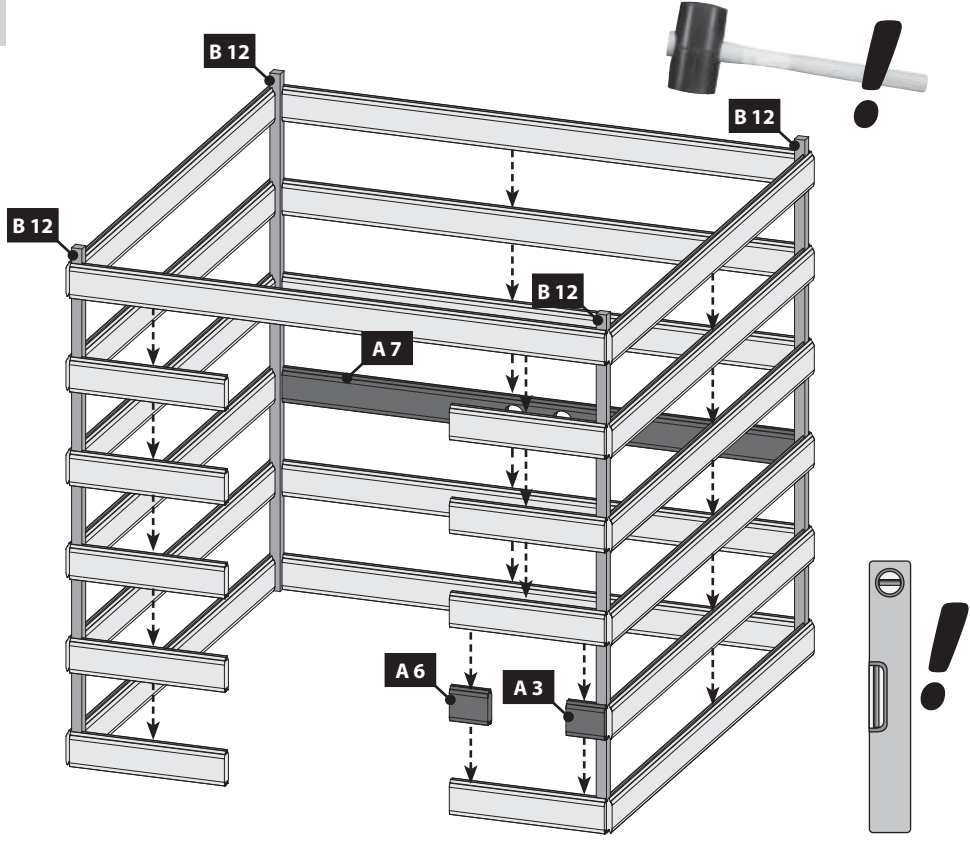
 vista dall'alto







 Achten Sie auf die gleiche Höhe
 Look for the same height
 Faites attention à la même hauteur
 Besteed aandacht aan de dezelfde hoogte

 Prestar atención a la misma altura
 Prestare attenzione alla stessa altezza
 Dávejte pozor na stejnou výšku

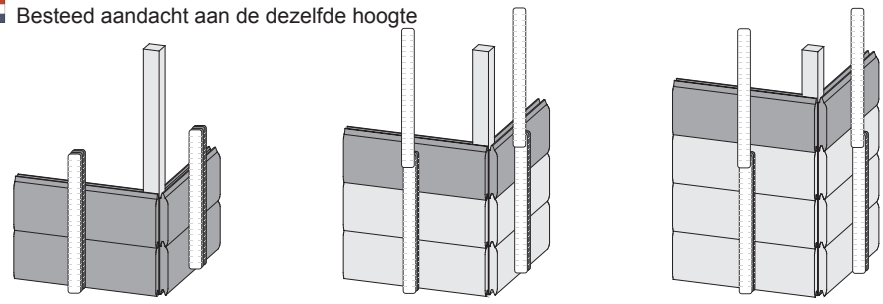

(02.1 + 02.2 → 02.3)

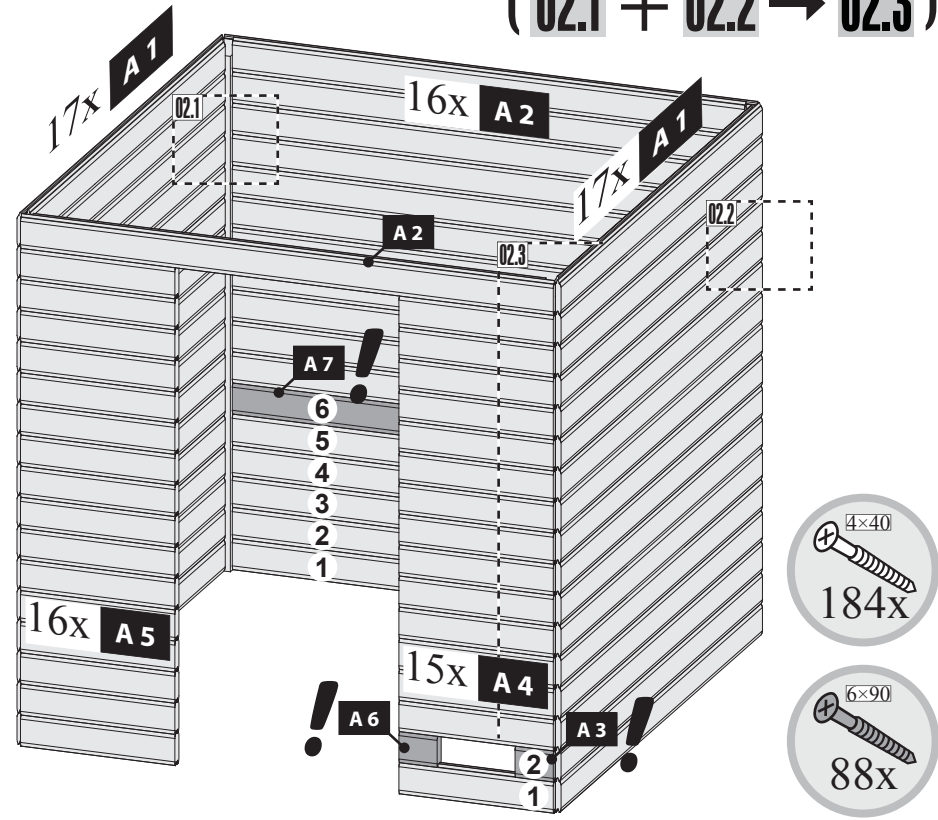

03

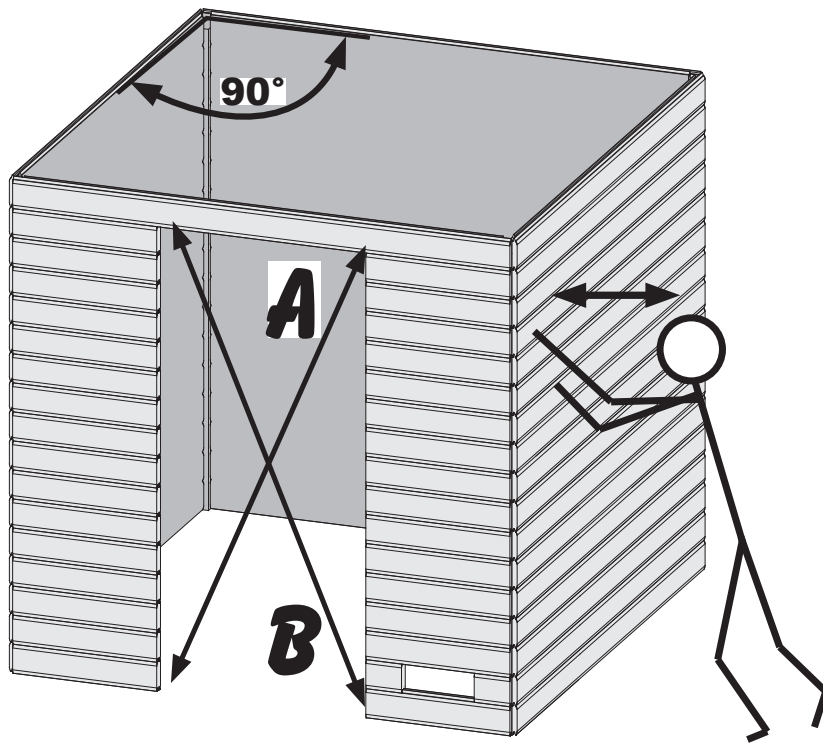

!!! A=B !!!

04

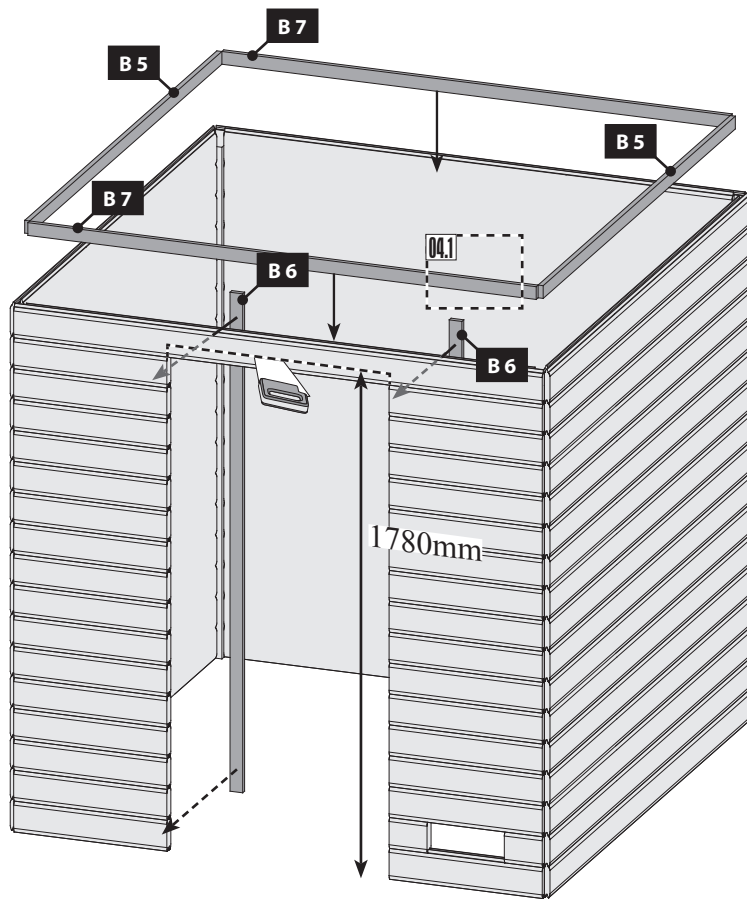

04.1

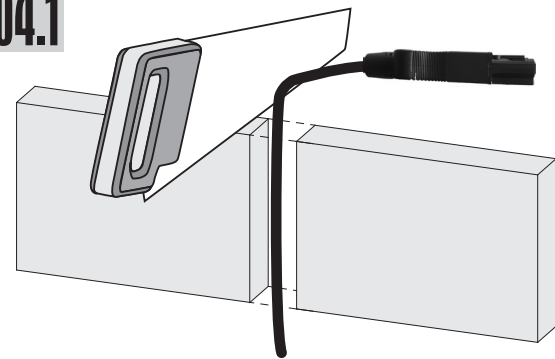

05

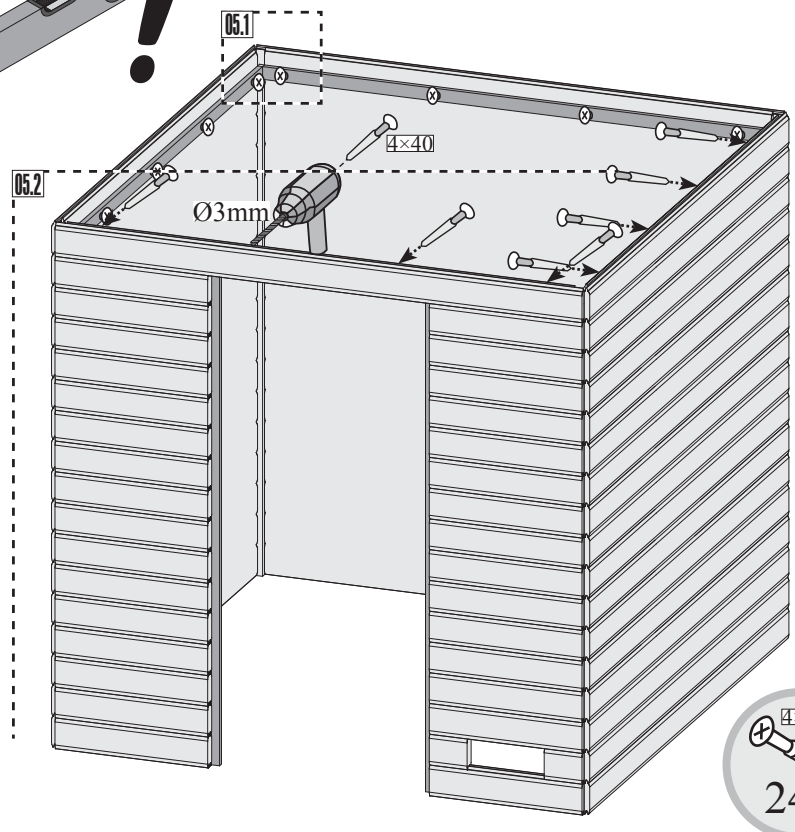
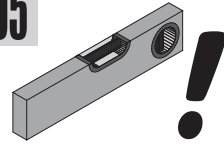

05.1

Bündig!
Affleurement!
Gelijk!
Aras!
Flush!
Combacia!
Stejný!

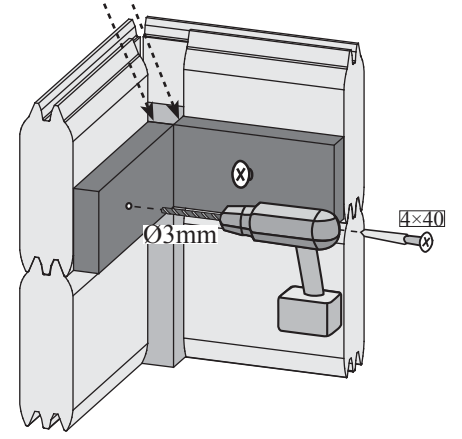

05.2

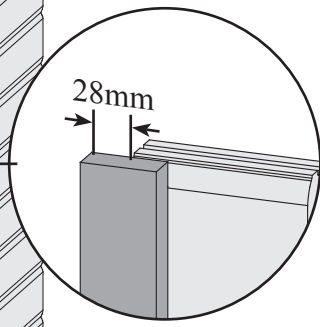
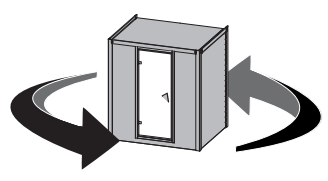
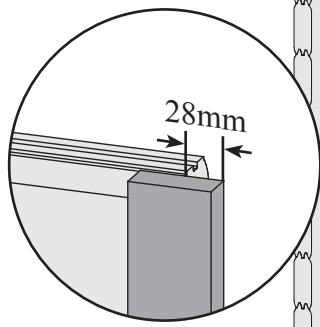
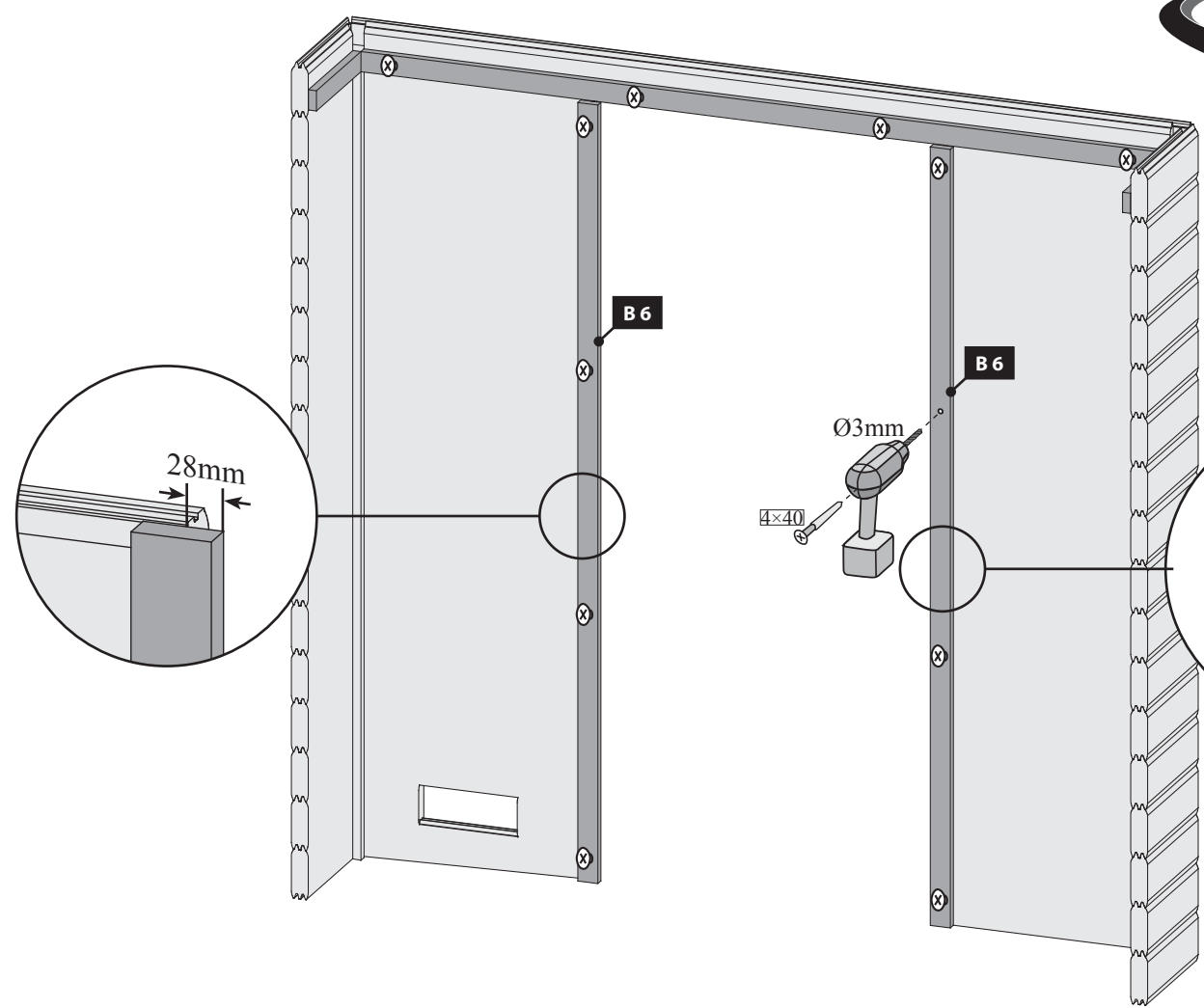



 Einbau Saunatür

 Sauna deur installatie

 Sauna Instalace dveře

 Installation de porte Sauna

 Instalación de la puerta Sauna

 Sauna door installation

 Installazione porta Sauna

!!! 01 → 03 **!!!**

06

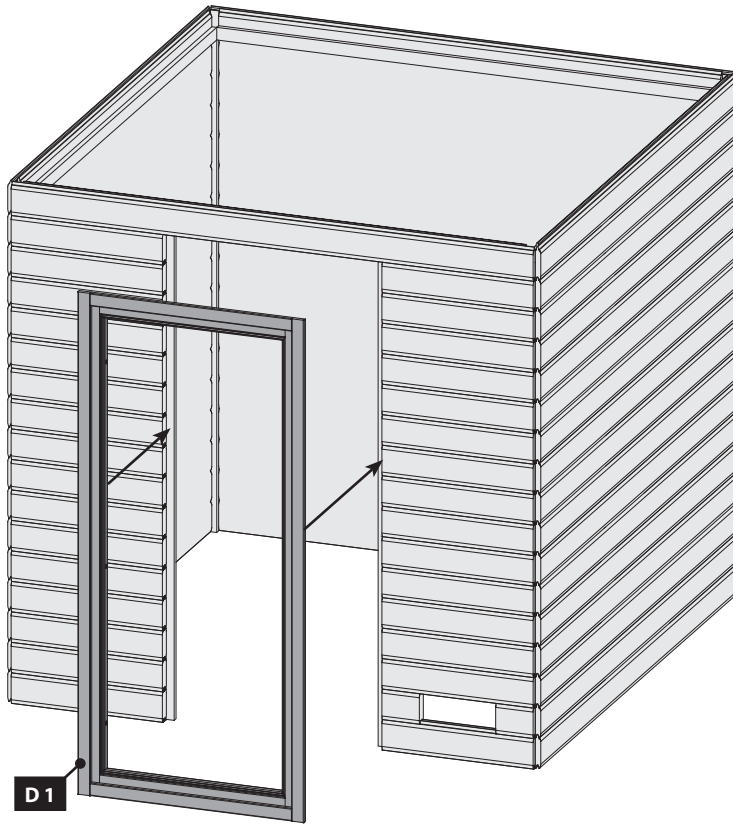

07

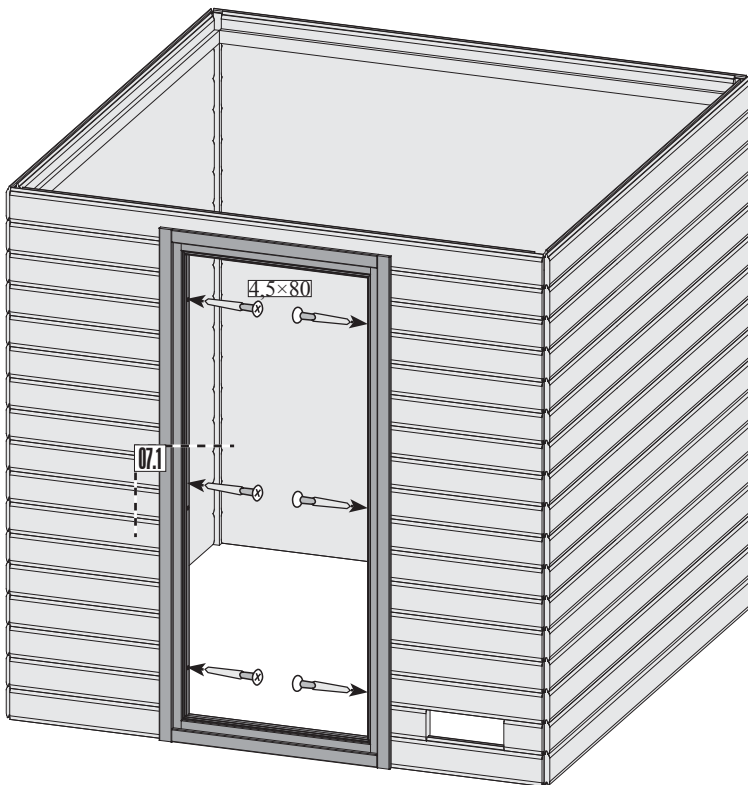

07.1-1

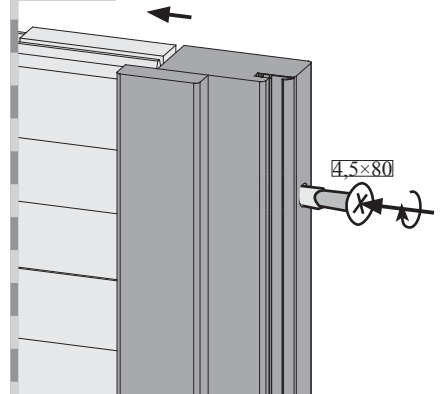

07.1-2

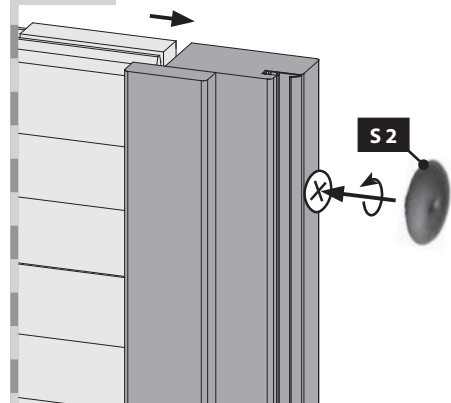

08

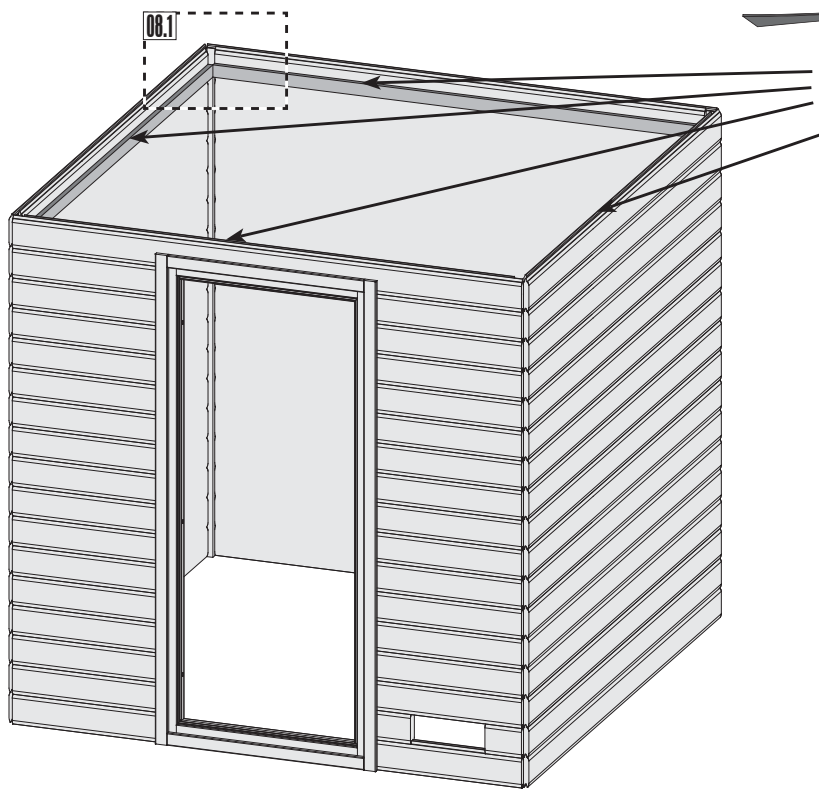

08.1

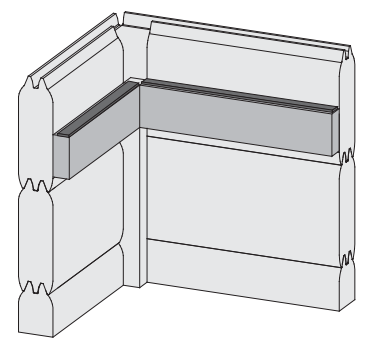

09

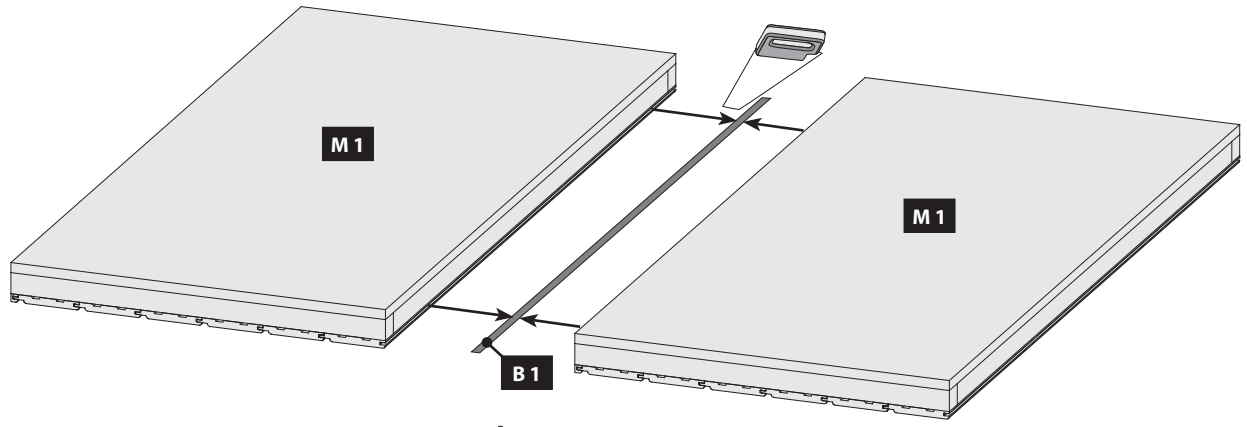

10

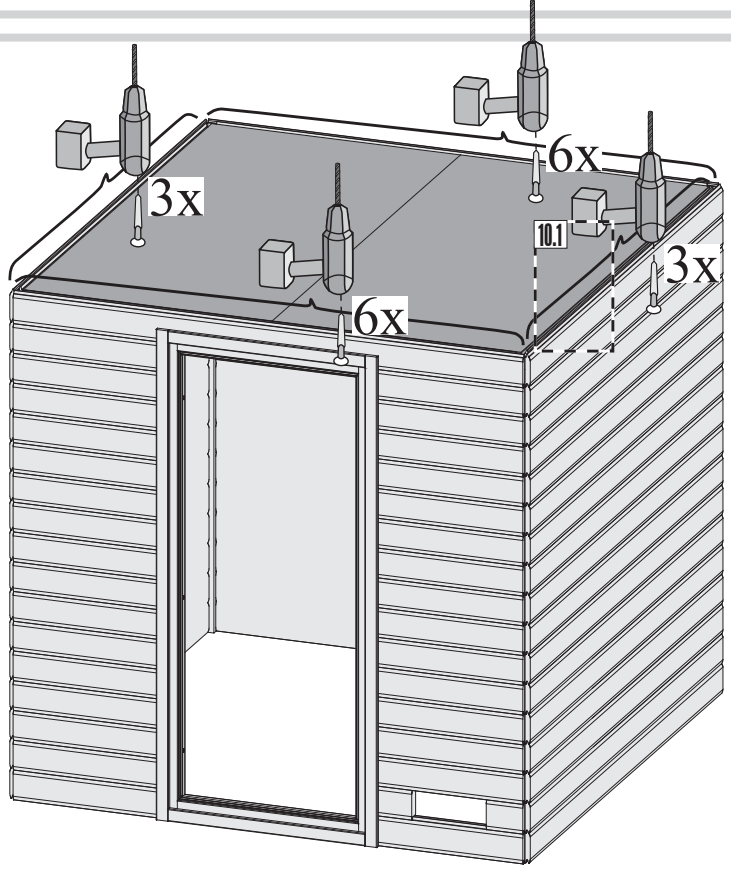

10.1

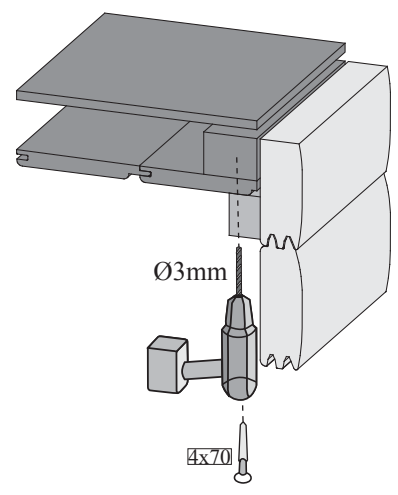

11 2x

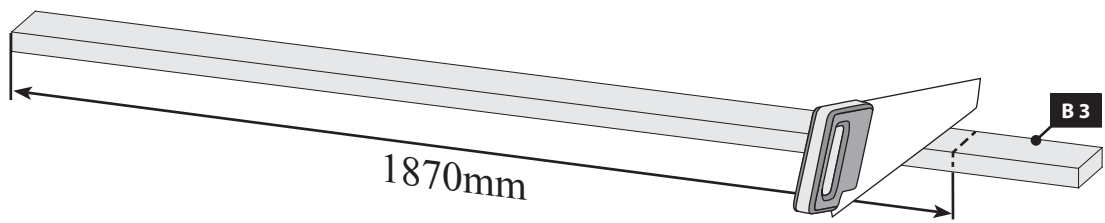

12 4x

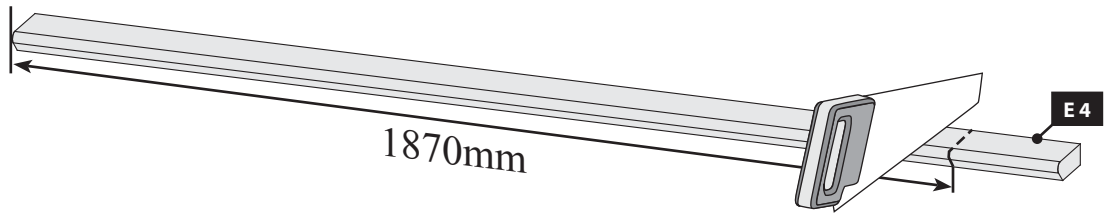

13

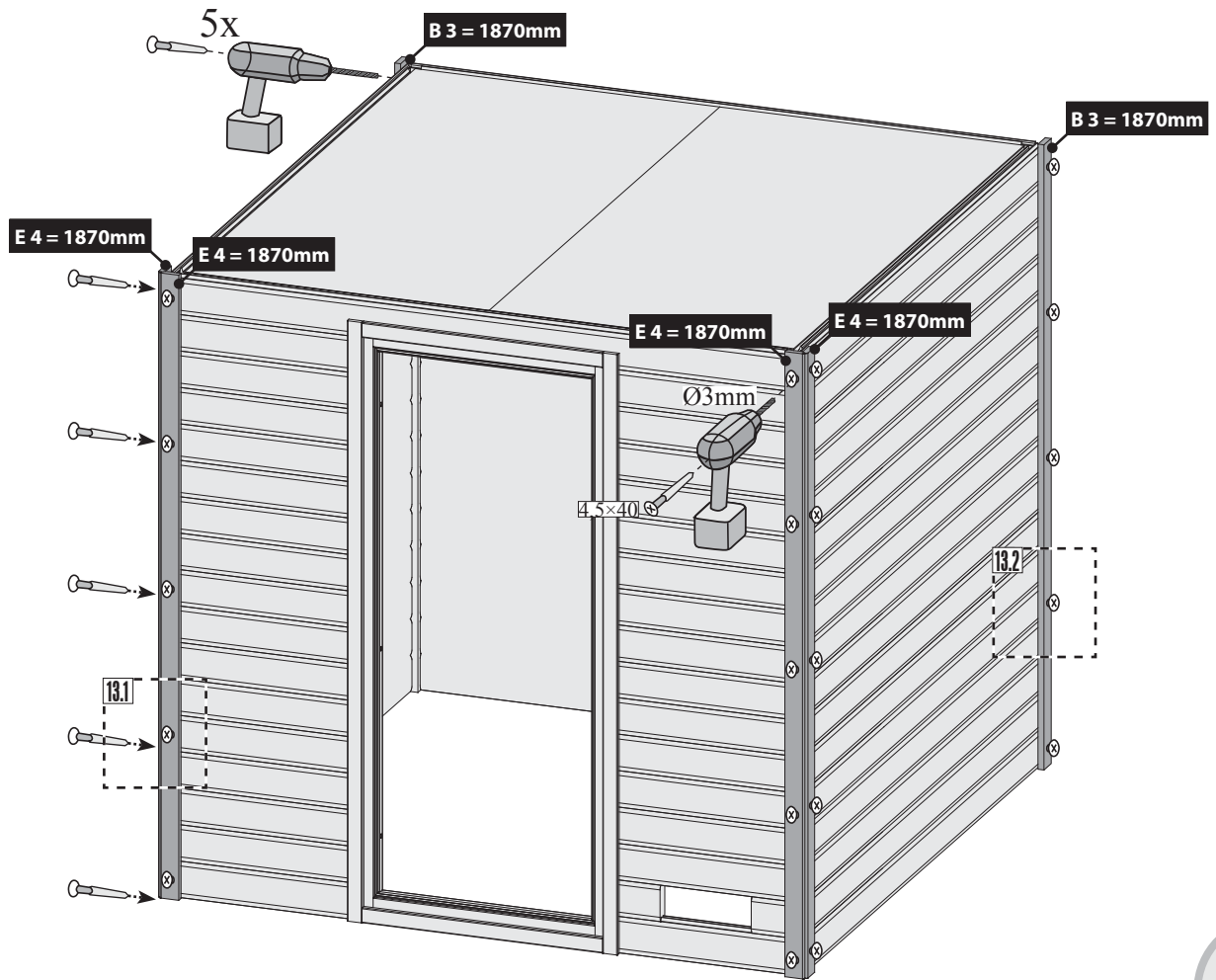

13.1

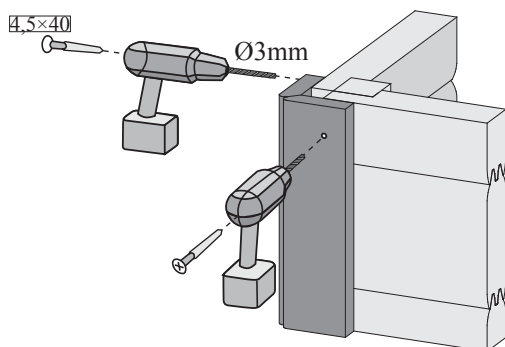

13.2

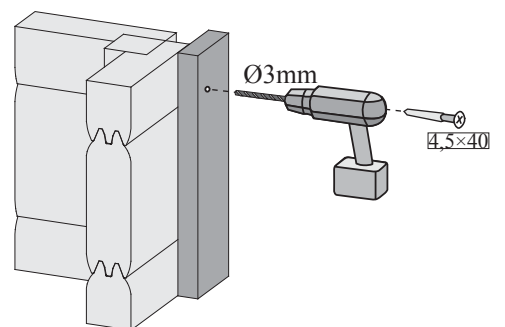

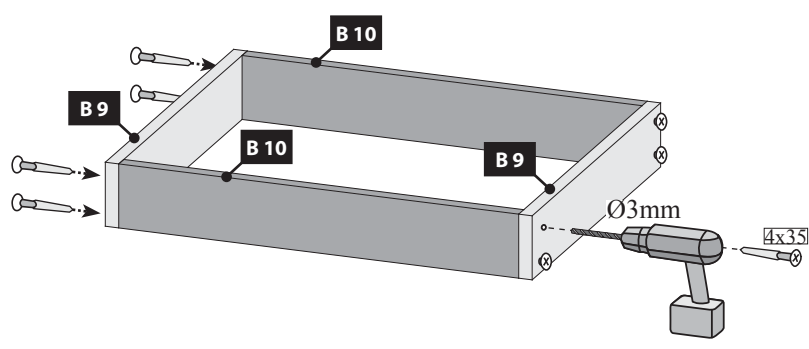
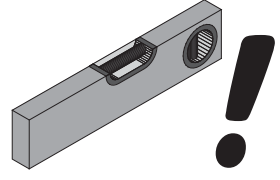
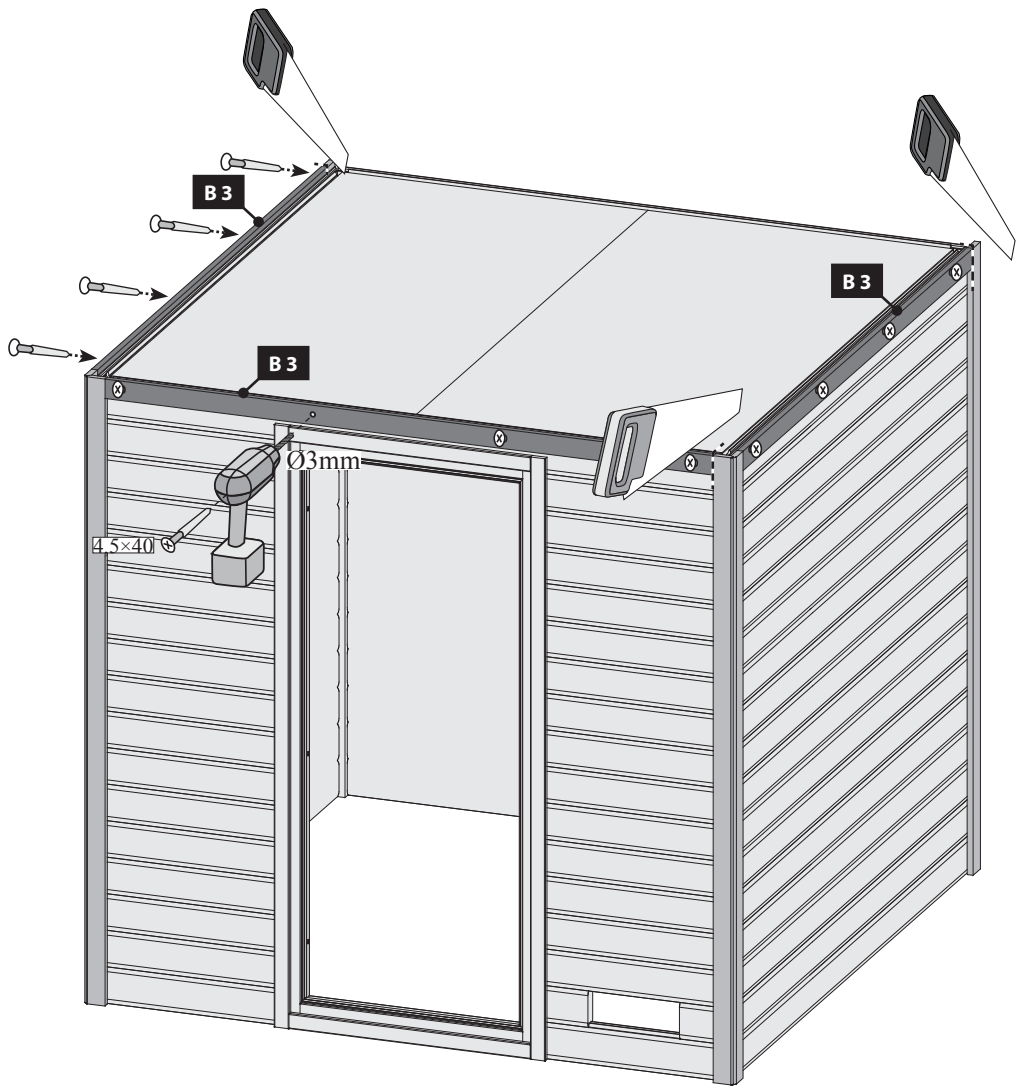

16 a

-  Nur bei 9 kW-Ofen
-  Seulement 9 kW chauffe
-  Only 9 kW heater
-  Slechts 9 kW heater
-  Sólo calentador de 9 kW
-  Solo riscaldamento 9 kW
-  Pouze topné těleso 9 kW

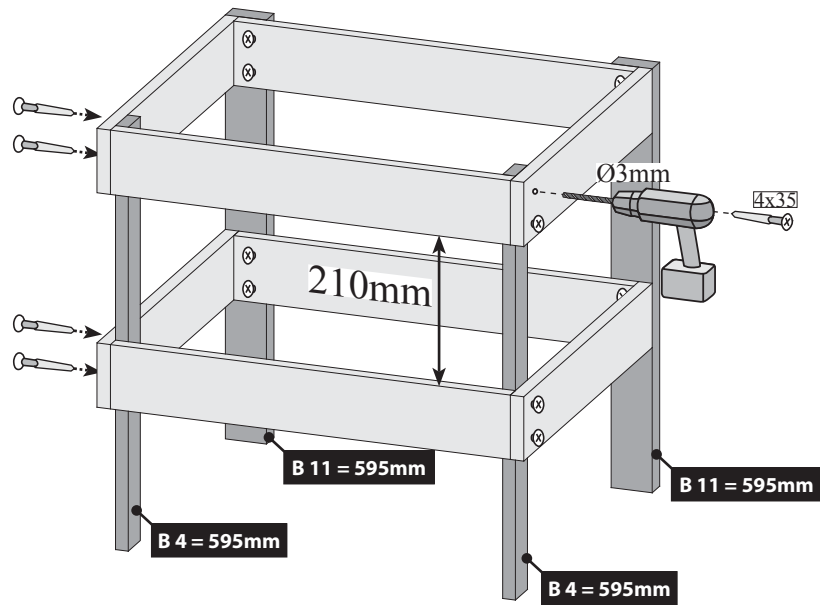
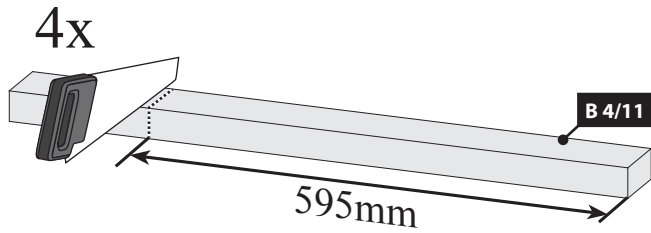

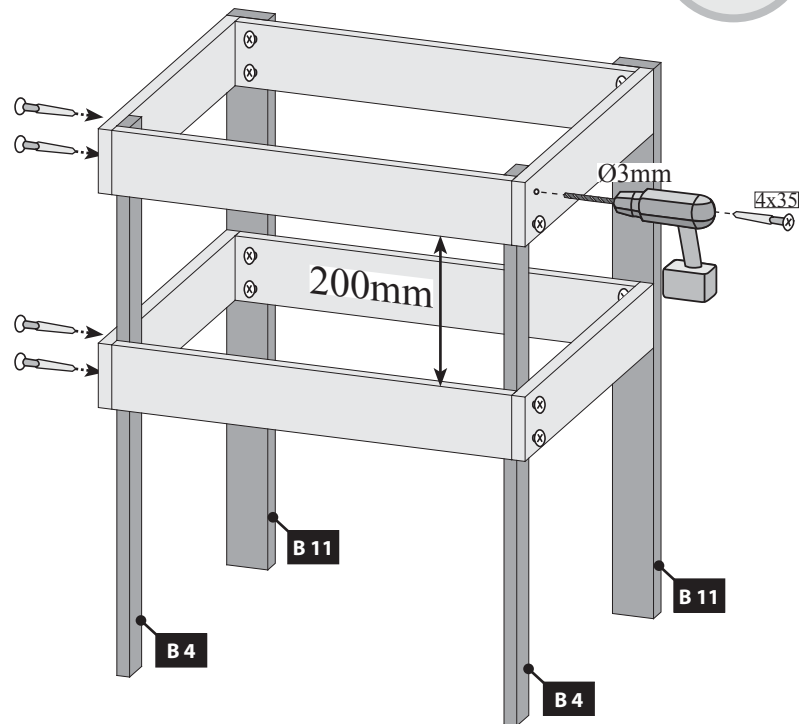

16 b

-  Bei allen anderen Öfen
-  Pour tous les autres fours
-  For all other furnaces
-  Voor alle andere ovens
-  Para todos los otros hornos
-  Per tutti gli altri tipi di forni
-  U všech ostatních pecích

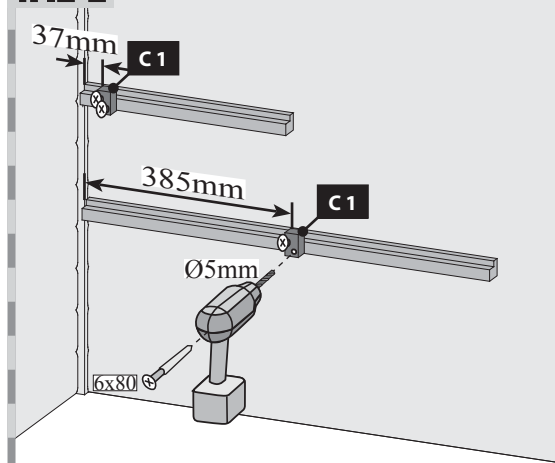
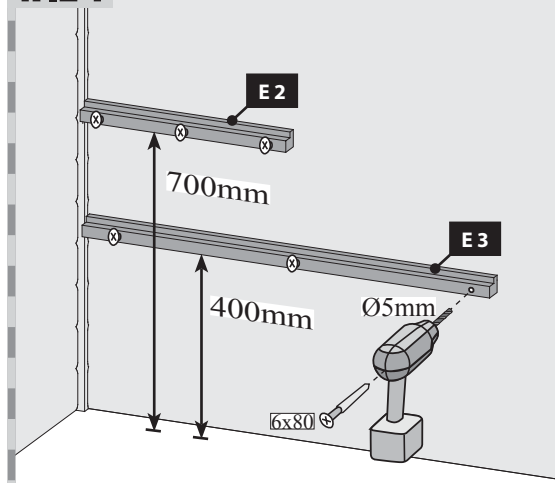
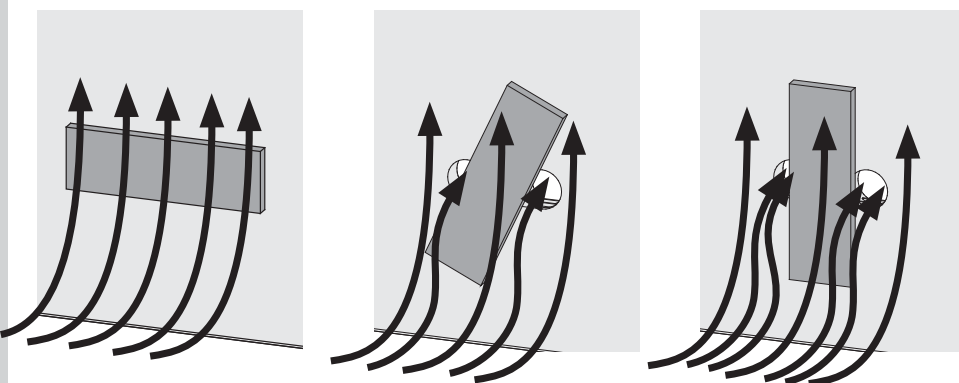
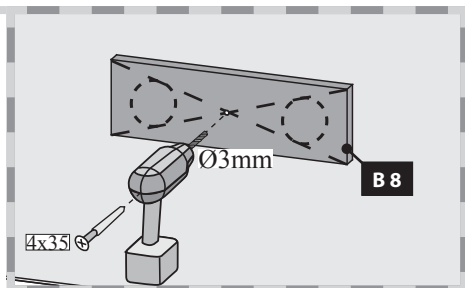
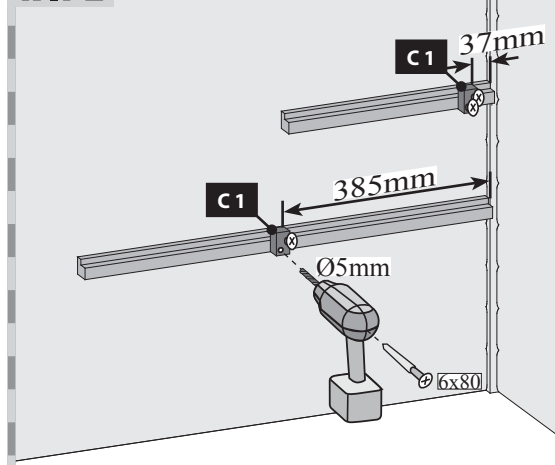
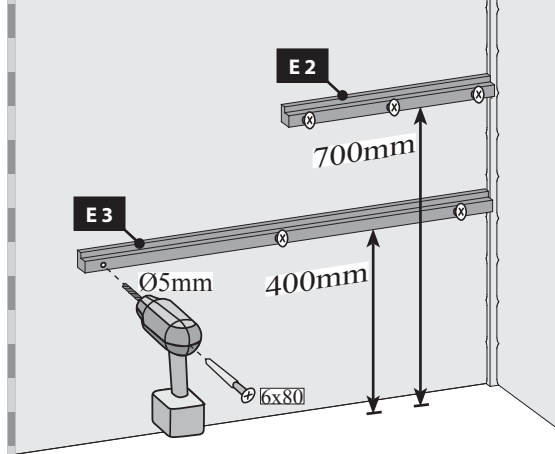
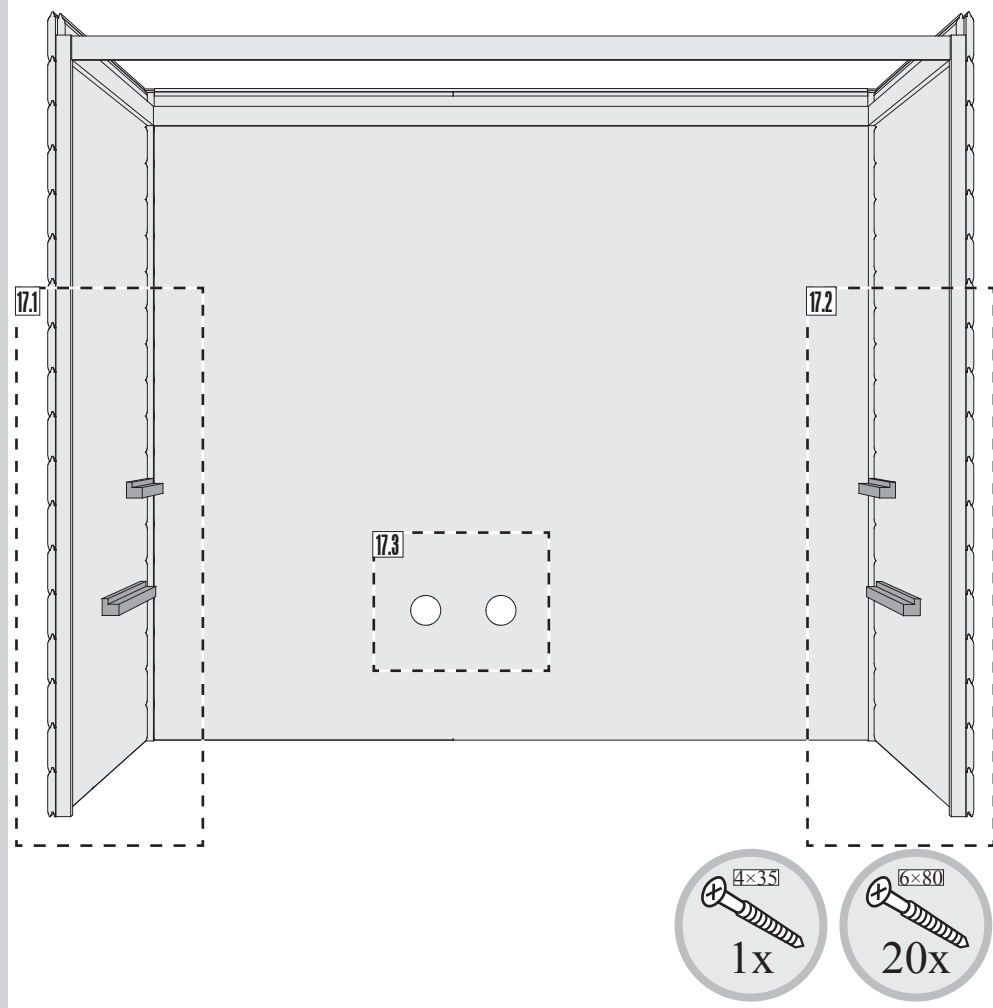





 Hier ist die Funktionsweise des Brettes abgebildet. Regeln Sie damit die Abluft nach Ihren eigenen Wünschen.

 Ceci représente le mode de fonctionnement de la planche. Avec elle, réglez l'écoulement de l'air selon vos désirs.

 This figure shows the functional principle of the board. Regulate the exhaust air according to your own wishes.

 Hier is de werking van het plankje afgebeeld. Regel daarmee de luchtafvoer naar eigen wens.

 Aquí está representada la forma de funcionamiento de la tabla. Regule con ello el aire de salida según sus propios deseos.

 Viene illustrato il principio di funzionamento della tavoletta di regolazione della ventilazione. Con essa si può regolare a piacere la ventilazione.

 Zde je zobrazená funkce desky. Regulujte s ní odsávací vzduch dle Vašeho přání.

18 2x

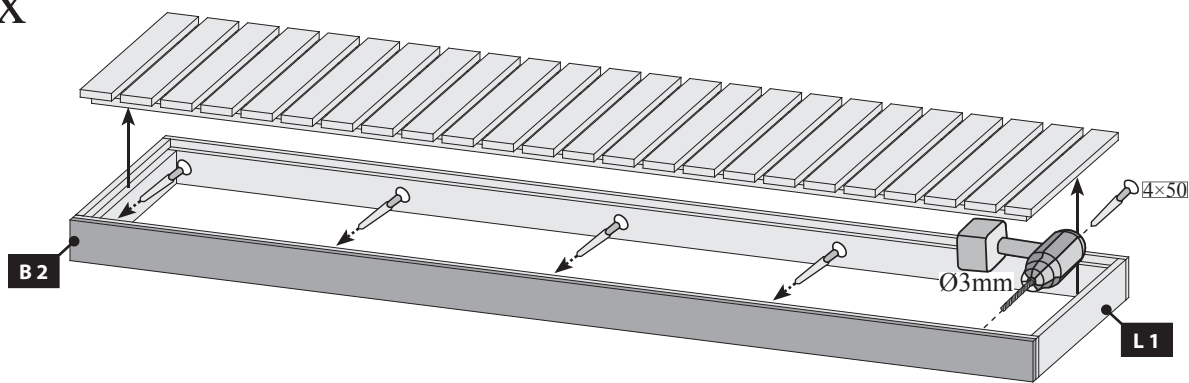

19

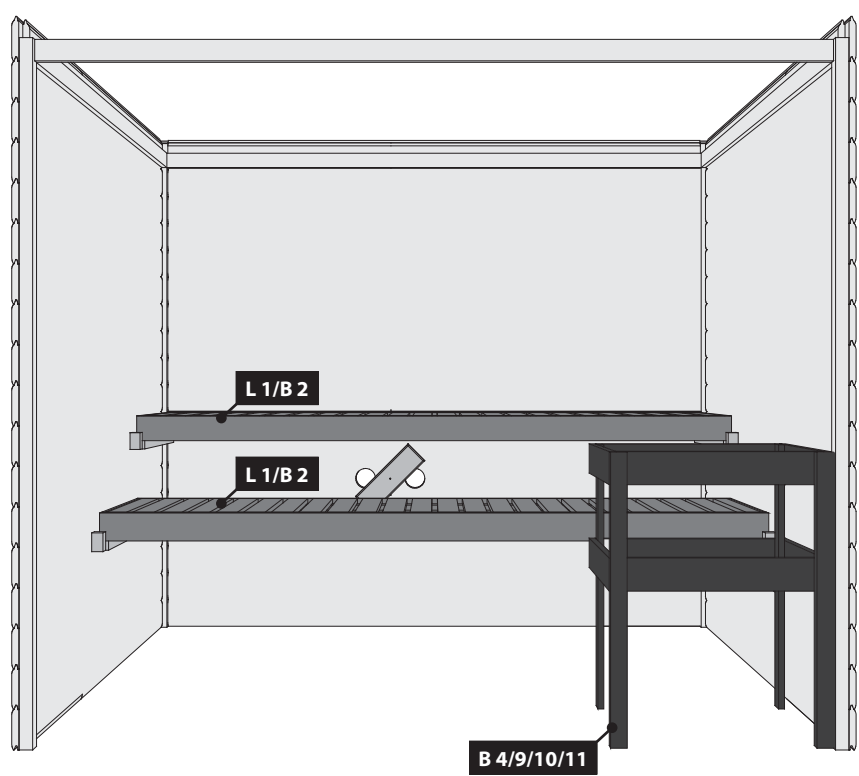

20

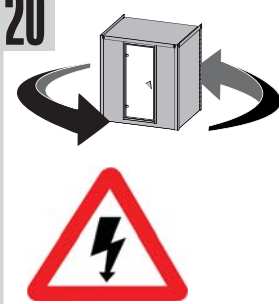

Bündig!
Affleurement!
Gelijk!
Aras!
Flush!
Combacia!
Stejný!

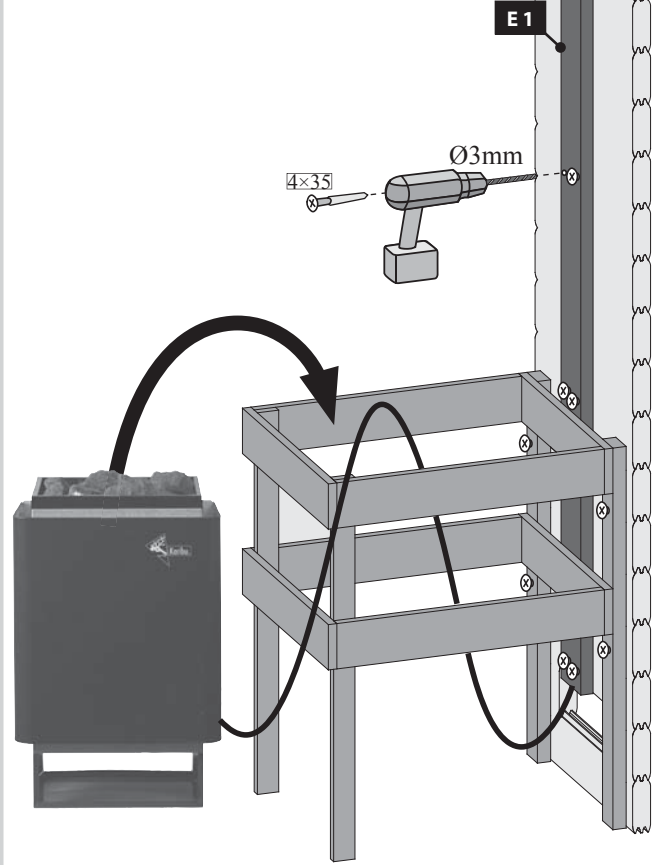

- Einbau Saunatür**
- Sauna deur installatie**
- Sauna Instalace dveře**
- Sauna door installation**
- Instalación de la puerta Sauna**
- Installation de porte Sauna**
- Installazione porta Sauna**

!!! 04 → ... !!!

66683

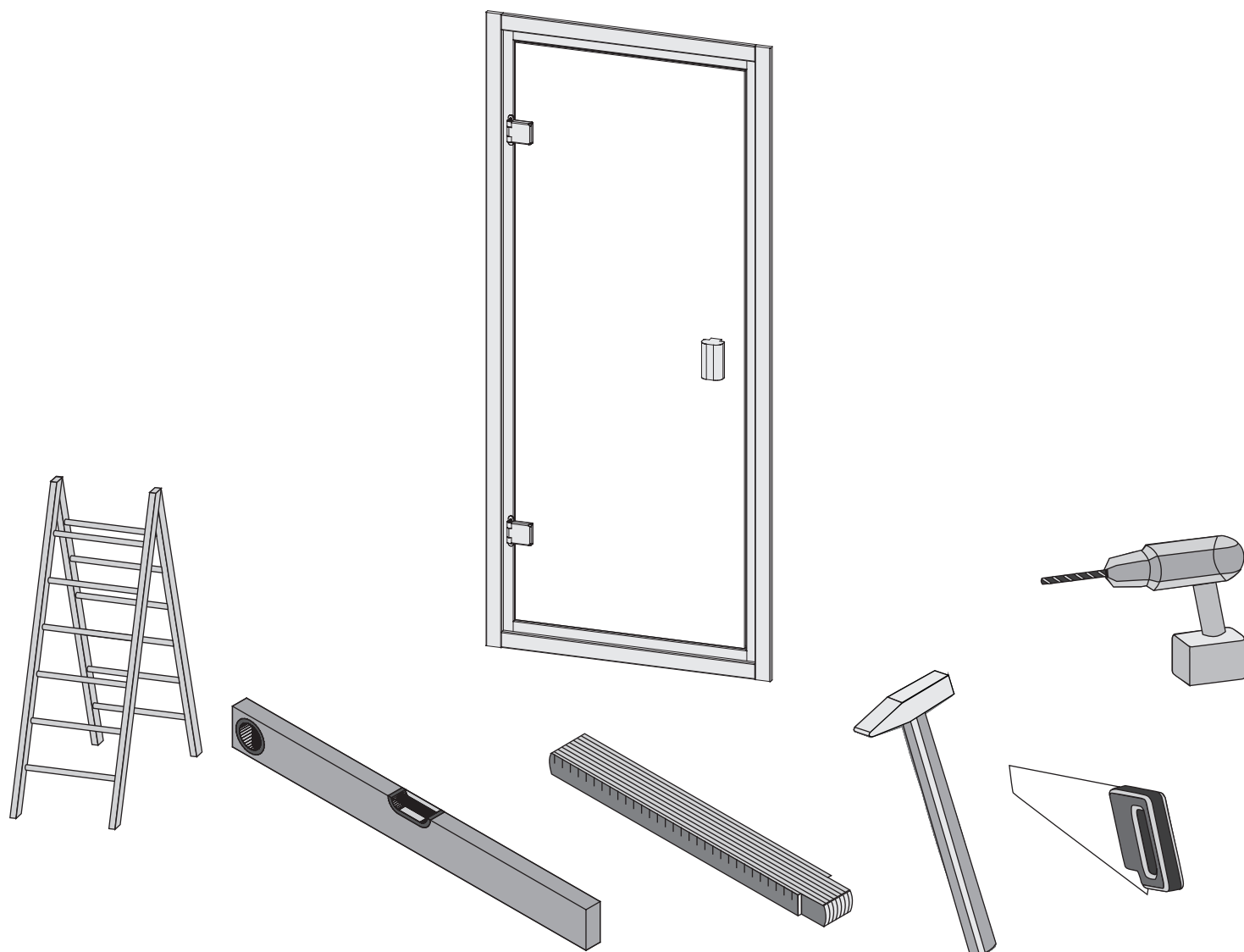

Aufbauanleitung



notice de montage



Building Instructions



montagehandleiding



Instrucciones de construcción



Istruzioni per il montaggio



Montážní návod



Service-Hotline: +49 421 38693 33



Vergleichen Sie zuerst die Materialliste mit Ihrem Paketinhalt! Bitte haben Sie Verständnis, dass Beanstandungen nur im nicht aufgebauten Zustand bearbeitet werden können!



En primer lugar, compare la lista de material con el contenido del paquete. Rogamos entienda que las reclamaciones sólo pueden ser tramitadas antes de montar el objeto!



Nejprve přezkontrolujte obsah balení podle materiálového listu! Mějte pochopení pro to, že případnou reklamaci se můžeme zabývat pouze tehdy, když díly nebudou smontované! Za pomoci tohoto seznamu můžete jednotlivé díly přiřadit k montážnímu návodu.



Vergelijk eerst de lijst van materialen met de inhoud van uw pakket! Reclamaties kunnen alleen in behandeling worden genomen zolang de onderdelen nog niet zijn gemonteerd!



First compare the list of materials with your package contents! Please understand that complaints can be processed in the non-built status only!



Commencez par comparer la liste du matériel avec le contenu de votre paquet! Sachez que nous traitons uniquement les réclamations concernant le matériel à l'état non monté!



Confrontate questa distinta materiali prima con il contenuto del pacchetto! Vi preghiamo di comprendere che eventuali reclami possono essere accolti solo prima del montaggio!

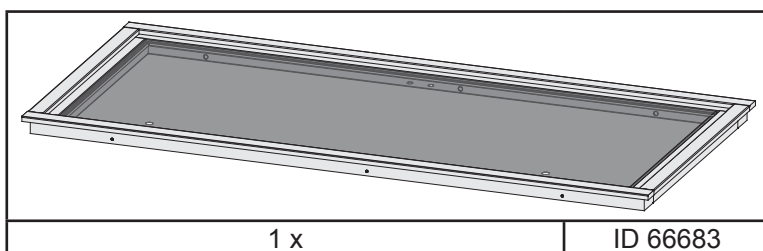
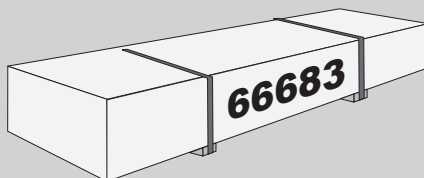

01

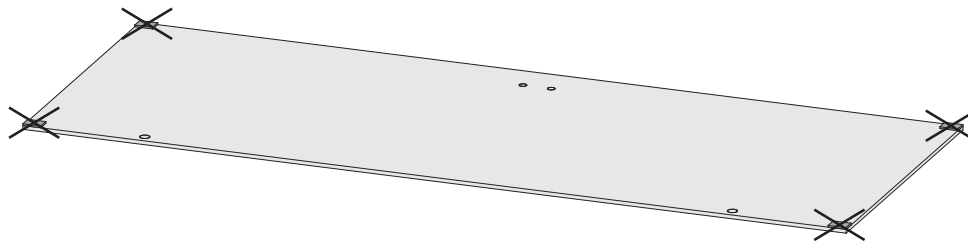



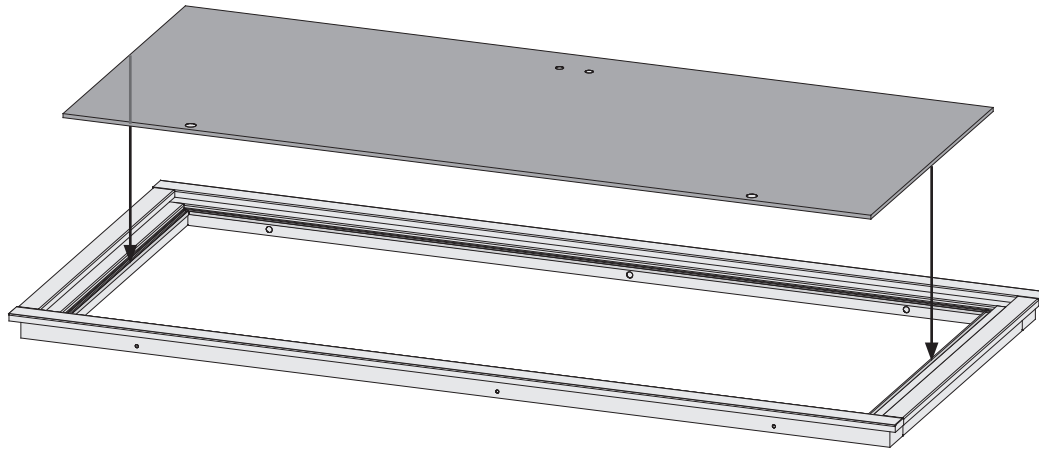

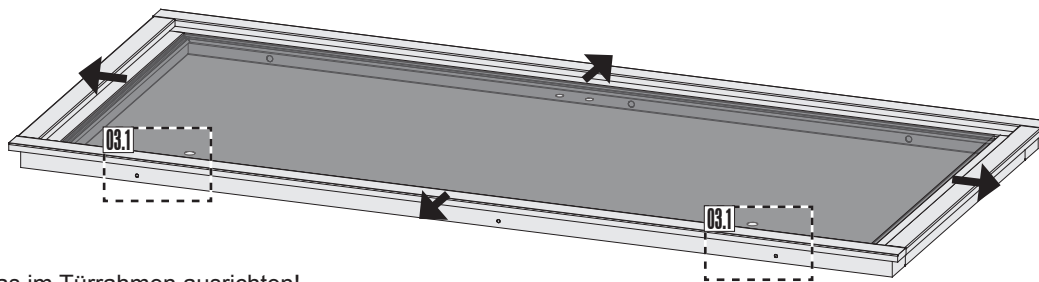

02



03



-  Das Saunatürglas im Türrahmen ausrichten!
-  Bien aligner le verre à vitre!
-  To start building up the door you need to center the glass in the wooden frame!
-  Plaats het glas van de sauna deur in het midden van het kozijn!
-  ¡Centrar la puerta de cristal dentro del marco!
-  Allineare il vetro dello sportello sauna al telaio della porta!
-  Skleněná dvířka sauna v zárubně zarovnáni!

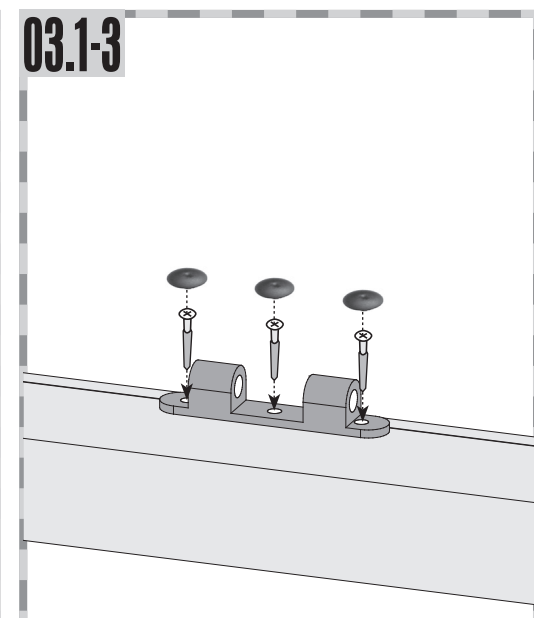
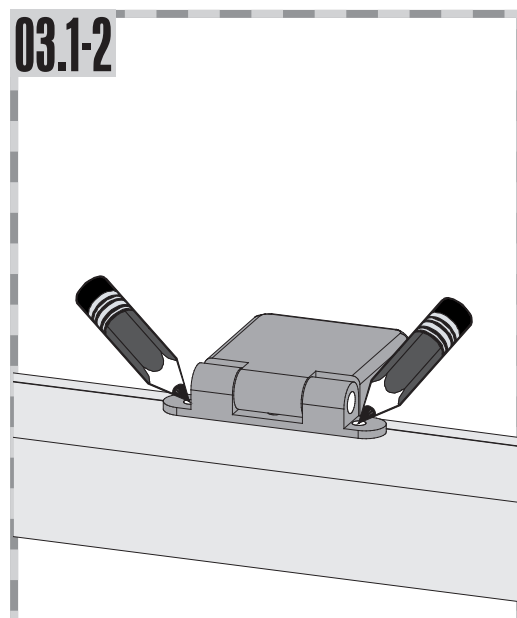
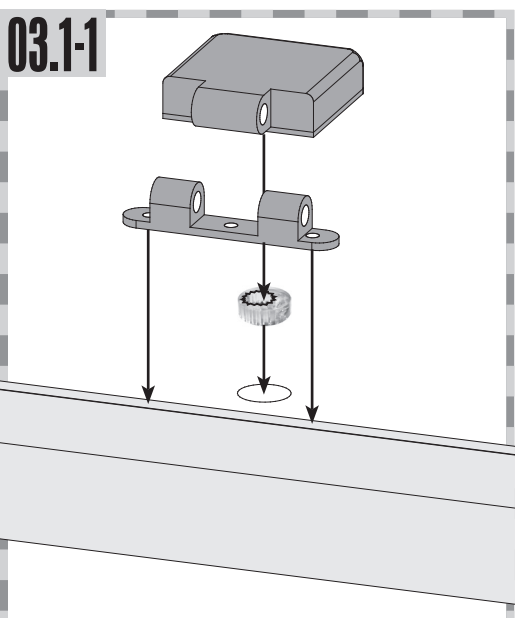

 Einbau Saunatür

 Sauna deur installatie

 Sauna Instalace dveře

 Installation de porte Sauna

 Instalación de la puerta Sauna

 Sauna door installation

 Installazione porta Sauna

04

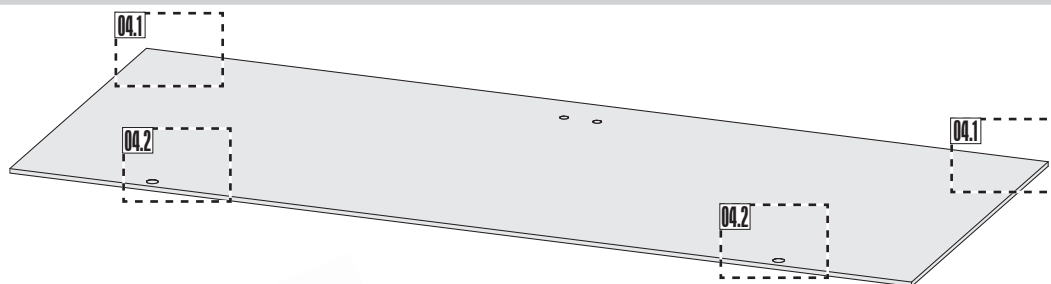

04.1-1

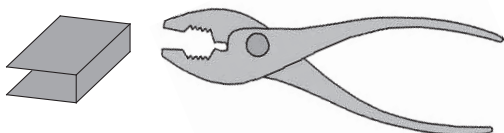

04.1-2

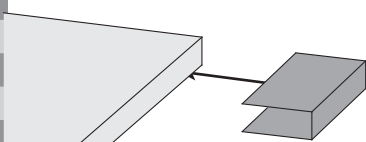

04.1-3

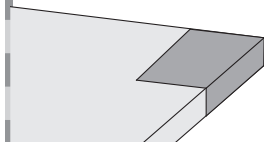

04.2-1

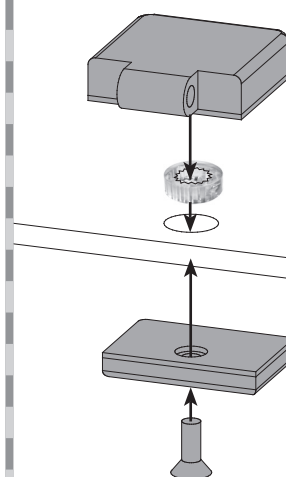

04.2-2

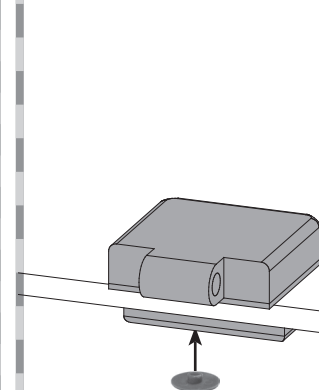

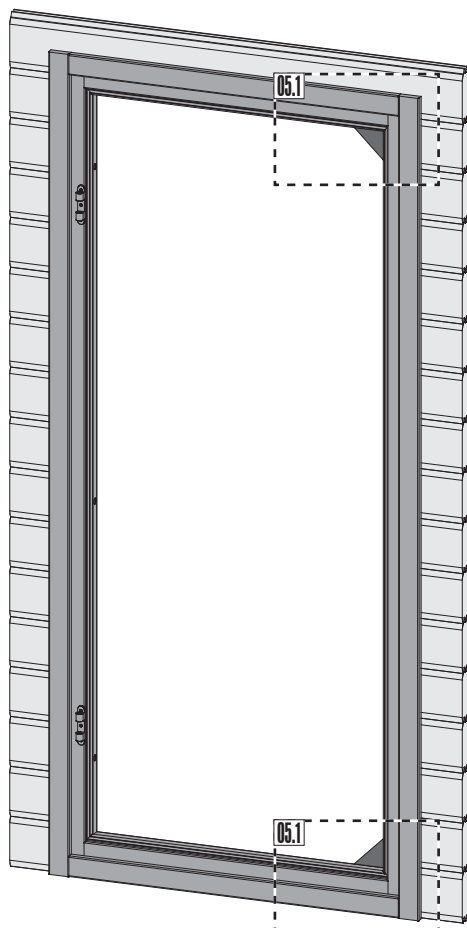

05





 Achtung: Alle Verstell-Excenter müssen in der Glasscheibe die gleiche Grundstellung haben!

 Attention: Tous les excenteurs de positionnement doivent avoir la même position de base dans la vitre!

 Attention: All adjustable eccentrics must have the same basic adjustment in the glass panel!

 Figyelmeztetés: az összes állítható excentrikusnak ugyanazt a beállítást kell mutatnia a üveglapon!

 Atención: Todos los excéntricos regulables tienen que tener la misma posición base en la hoja de cristal.

 Attenzione: Tutti gli eccentrici di regolazione devono avere la stessa posizione base nella lastra di vetro!

 Poznámka: Všechny nastavovací podivínů musí mít stejný základní polohy ve skle!

05.1-1

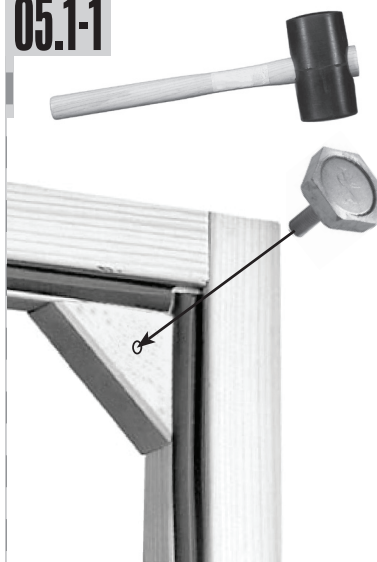

05.1-2



 Einbau Saunatür

 Sauna deur installatie

 Sauna Instalace dveře

 Installation de porte Sauna

 Instalación de la puerta Sauna

 Sauna door installation

 Installazione porta Sauna

06

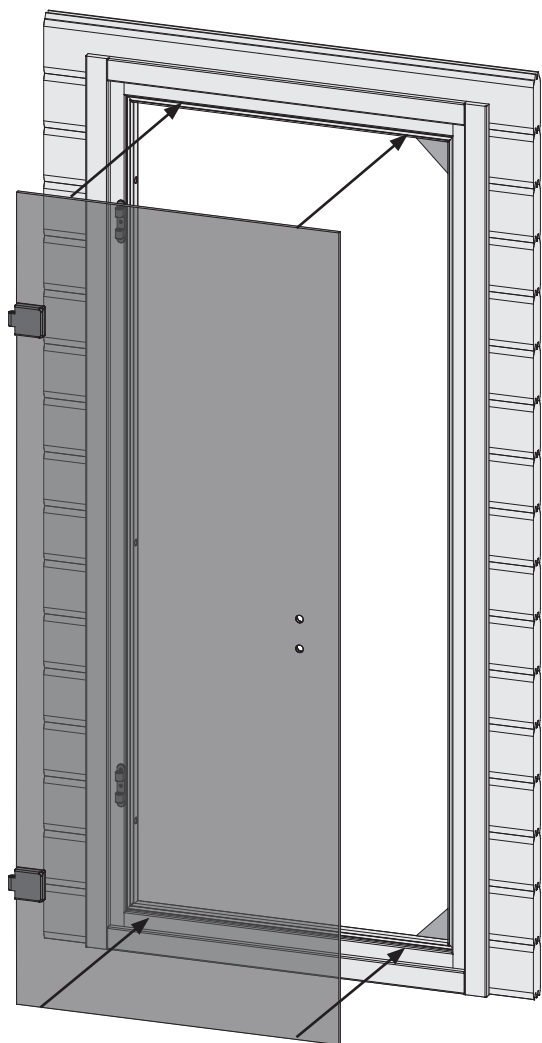

07

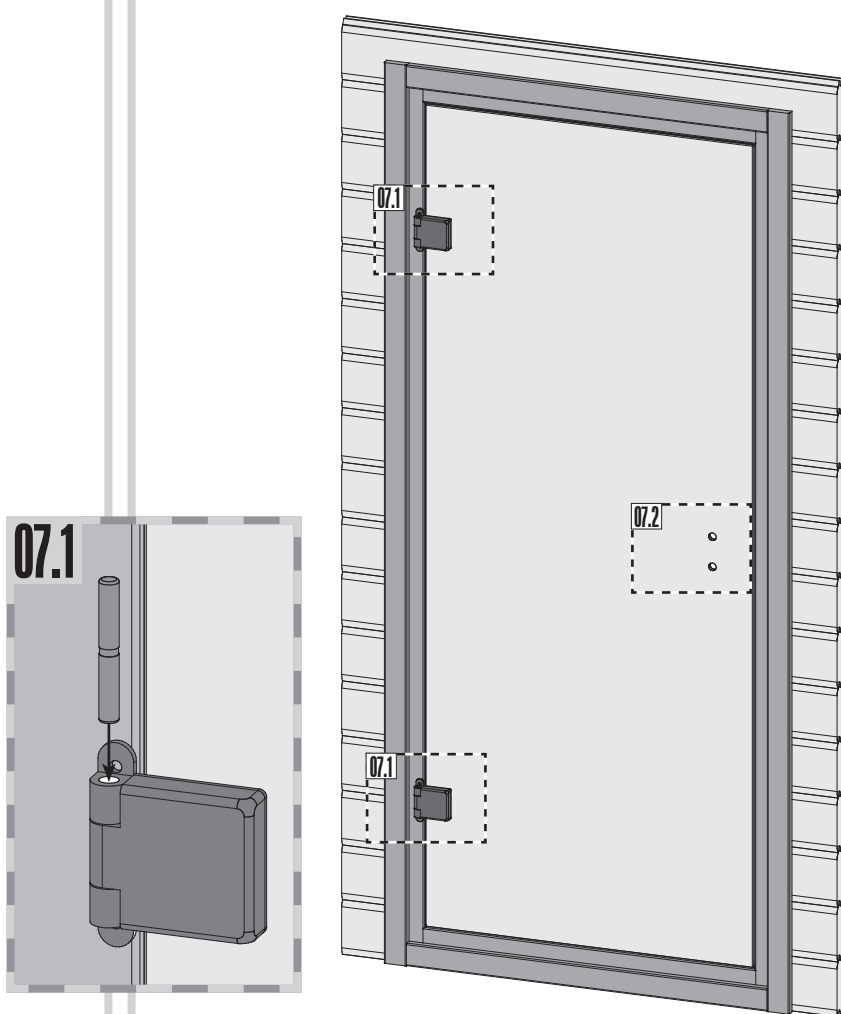

07.2-1

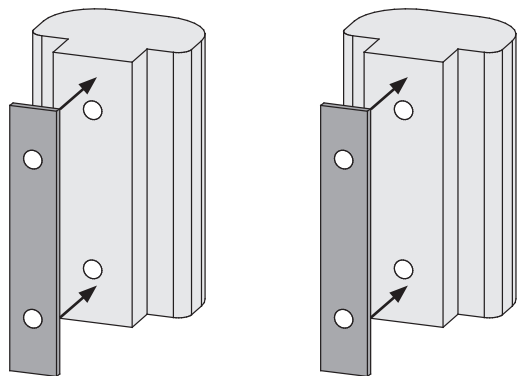

07.2-2

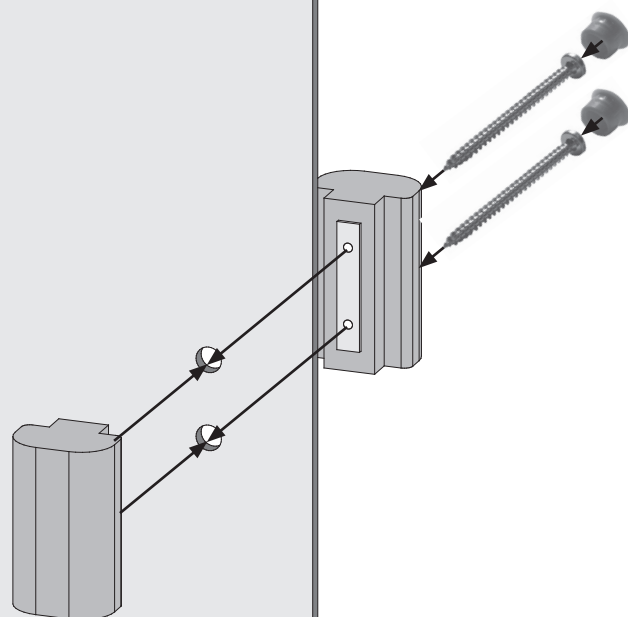

 Einbau Saunatür

 Sauna deur installatie

 Sauna Instalace dveře

 Installation de porte Sauna

 Instalación de la puerta Sauna

 Sauna door installation

 Installazione porta Sauna

08

Seitenverstellung + Höhenverstellung

Achtung: Alle Verstell-Excenter müssen in der Glasscheibe die gleiche Grundstellung haben!

Positionnement latéral + positionnement hauteur

Attention: Tous les excentrés de positionnement doivent avoir la même position de base dans la vitre!

Lateral adjustment + height adjustment

Attention: All adjustable eccentrics must have the same basic adjustment in the glass panel!

Zijverstelling + hoogteverstelling

Attentie: alle excentrische verstelelementen moeten in dezelfde stand in de glasplaat worden geplaatst!

Regulación lateral + regulación de la altura

Atención: Todos los excéntricos regulables tienen que tener la misma posición base en la hoja de cristal.

Regolazione laterale + regolazione dell'altezza

Attenzione: Tutti gli eccentrici di regolazione devono avere la stessa posizione base nella lastra di vetro!

Boční nastavení + nastavení výšky

Poznámka: Všechny nastavovací podivínů musí mít stejný základní polohy ve skle!

