

80393

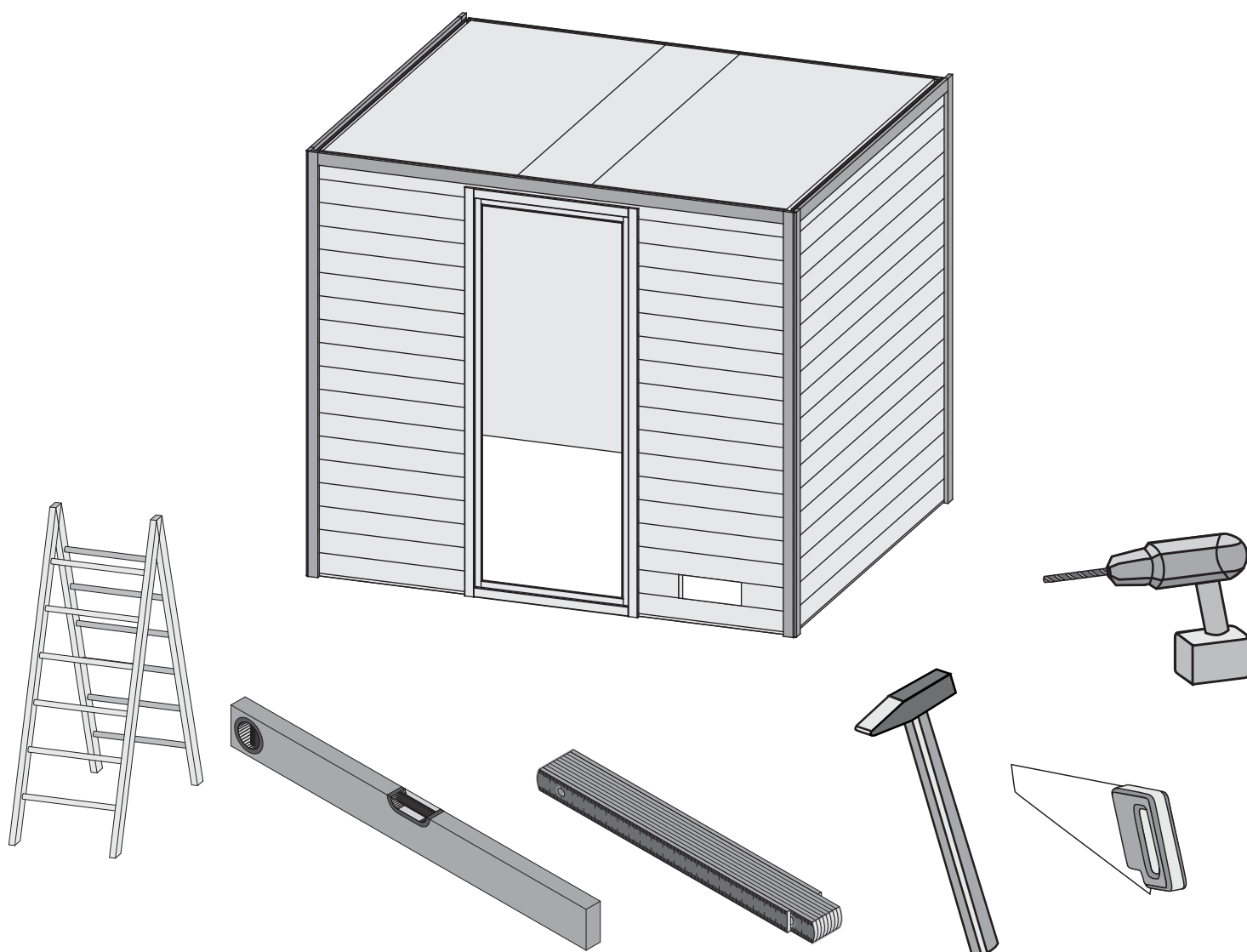

 **Aufbauanleitung**

 **notice de montage**

 **Building Instructions**

 **montagehandleiding**

 **Instrucciones de construcción**

 **Istruzioni per il montaggio**

 **Montážní návod**

 **Service-Hotline: +49 421 38693 33**



Vergleichen Sie zuerst die Materialliste mit Ihrem Paketinhalt! Bitte haben Sie Verständnis, dass Beanstandungen nur im nicht aufgebauten Zustand bearbeitet werden können!



En primer lugar, compare la lista de material con el contenido del paquete. Rogamos entienda que las reclamaciones sólo pueden ser tramitadas antes de montar el objeto!



Nejprve přezkontrolujte obsah balení podle materiálového listu! Mějte pochopení pro to, že případnou reklamaci se můžeme zabývat pouze tehdy, když díly nebudou smontované! Za pomoci tohoto seznamu můžete jednotlivé díly přiřadit k montážnímu návodu.



Vergelijk eerst de lijst van materialen met de inhoud van uw pakket! Reclamaties kunnen alleen in behandeling worden genomen zolang de onderdelen nog niet zijn gemonteerd!



First compare the list of materials with your package contents! Please understand that complaints can be processed in the non-built status only!



Commencez par comparer la liste du matériel avec le contenu de votre paquet! Sachez que nous traitons uniquement les réclamations concernant le matériel à l'état non monté!



Confrontate questa distinta materiali prima con il contenuto del pacchetto! Vi preghiamo di comprendere che eventuali reclami possono essere accolti solo prima del montaggio!

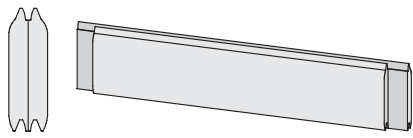
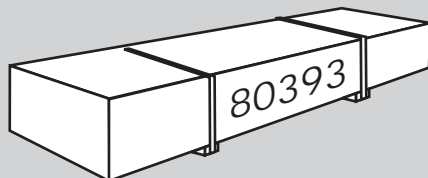

36 x A1	1881 x 121 x 38mm	ID 21429
18 x A2	2231 x 121 x 38mm	ID 21463

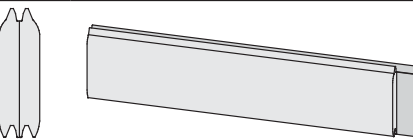

1 x A3	200 x 121 x 38mm	ID 80382
16 x A4	725 x 121 x 38mm	ID 21869

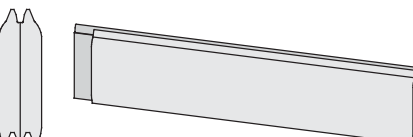

17 x A5	725 x 121 x 38mm	ID 21877
---------	------------------	----------

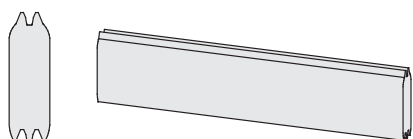

1 x A6	250 x 121 x 38mm	ID 80383
--------	------------------	----------

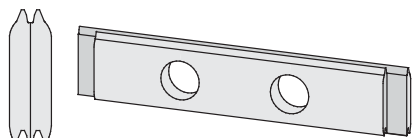

1 x A7	2231 x 121 x 38mm	ID 21866
--------	-------------------	----------

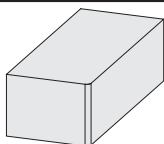

4 x C1	60 x 36 x 36mm	ID 5512
--------	----------------	---------

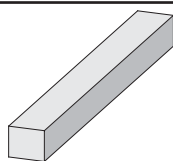

2 x B1	1920 x 20 x 3mm	ID 20799
2 x B2	2156 x 90 x 16mm	ID 71514
2 x B3	800 x 45 x 18mm	ID 24796
2 x B4	1809 x 45 x 18mm	ID 21831
2 x B5	2100 x 45 x 18mm	ID 19547
2 x B6	2159 x 45 x 18mm	ID 21483
4 x B7	2000 x 58 x 18mm	ID 48541
1 x B8	2250 x 58 x 18mm	ID 48543
1 x B9	300 x 95 x 18mm	ID 19130
4 x B10	480 x 95 x 18mm	ID 20930
4 x B11	565 x 95 x 18mm	ID 15498
2 x B12	800 x 58 x 28mm	ID 15493
4 x B13	1916 x 36 x 36mm	ID 21431

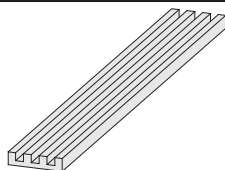

1 x E1	1820 x 110 x 26mm	ID 26480
--------	-------------------	----------

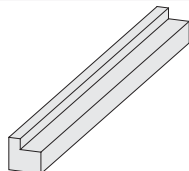

2 x E2	555 x 45 x 45mm	ID 40301
2 x E3	1100 x 45 x 45mm	ID 40302

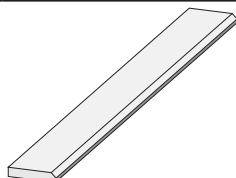

4 x E4	2000 x 58 x 18mm	ID 48545
--------	------------------	----------

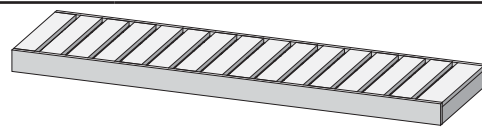

2 x L1	2156 x 550 x 90mm	ID 52068
--------	-------------------	----------

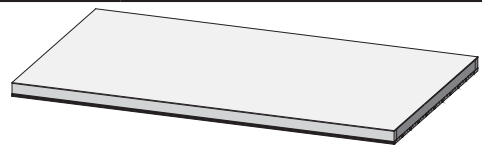

1 x M1	1839 x 349 x 55mm	ID 53731
2 x M2	1839 x 918 x 55mm	ID 21121



- Siehe Türpaket
- Opmerking Door Package
- Note Door Package
- Remarque Package porte
- Nota Paquete Puerta
- Nota Door Package
- Poznámka Door balíček

1 x D1		
--------	--	--



20 x	4 x 30mm	ID 3686
60 x	4 x 35mm	ID 3687
350 x	4 x 40mm	ID 21925
30 x	4 x 50mm	ID 3688
30 x	4 x 70mm	ID 3689
25 x	4,5 x 80mm	ID 9204
20 x	6 x 60mm	ID 14014
20 x	6 x 80mm	ID 47558
80 x	6 x 90mm	ID 26715



50 x

4,5 x 40mm

ID 26285

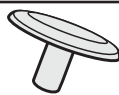

60 x S1

4 x 30mm

ID 26116

6 x S2

12 x 18mm

ID 46403

10m

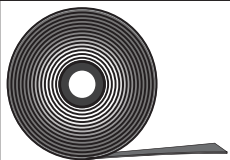

ID 14025

 Draufsicht

 vista desde arriba

 bovenaanzicht

 vista dall'alto

 Top view

 pùdorys

 vue de dessus

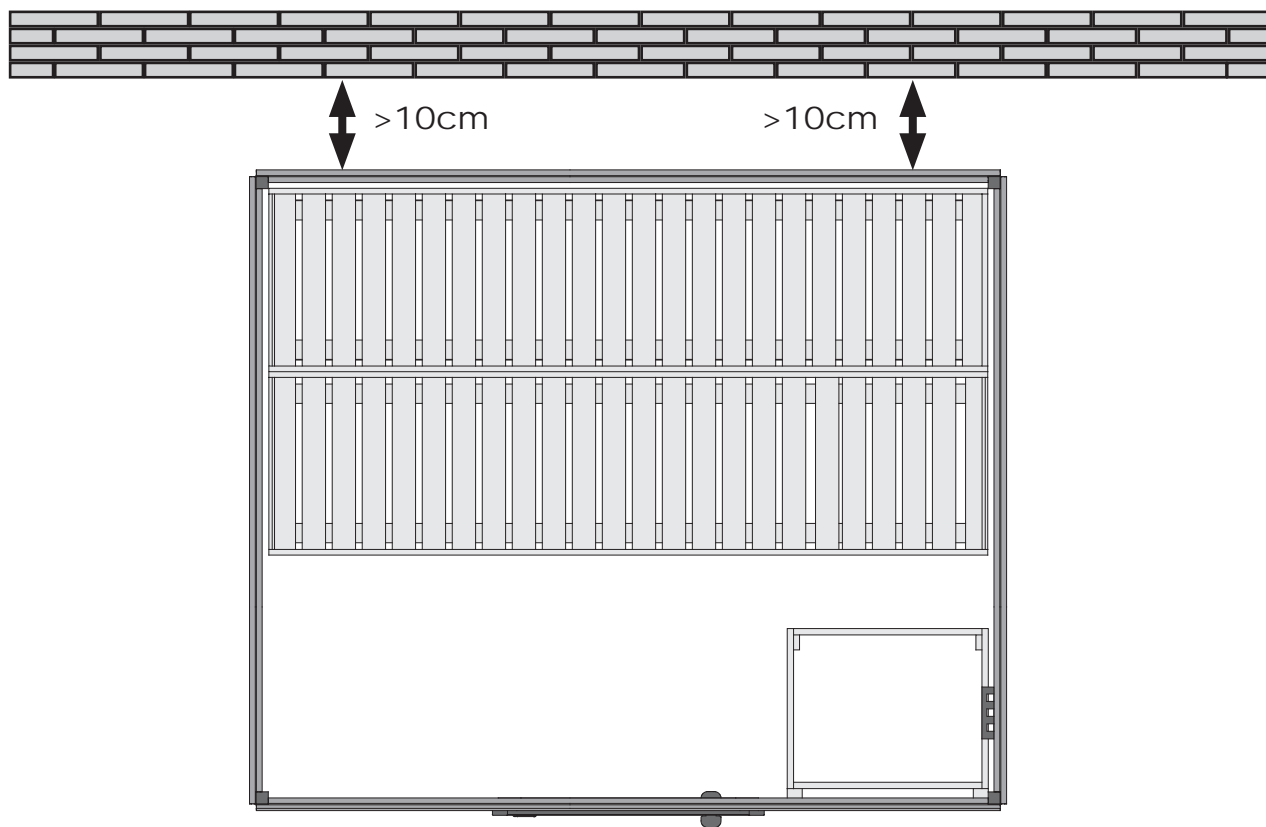

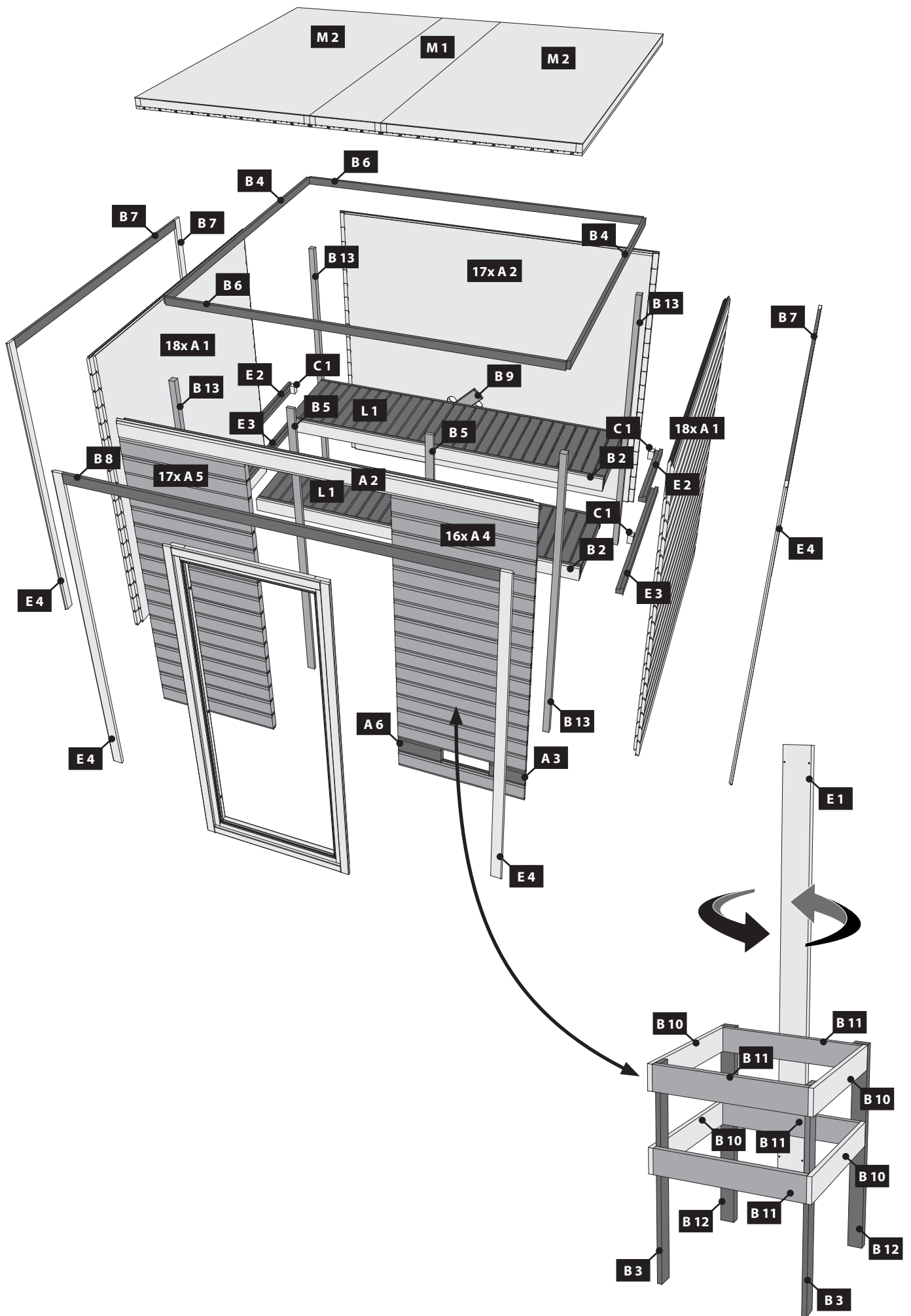

01

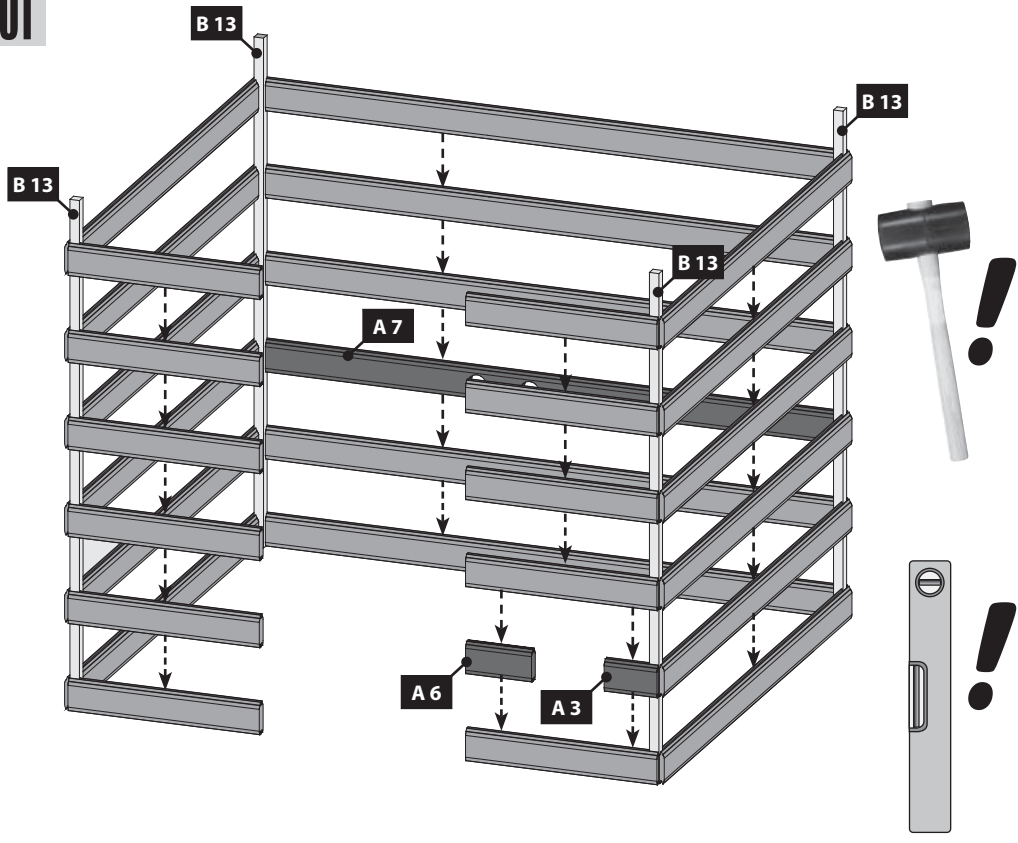

02.1

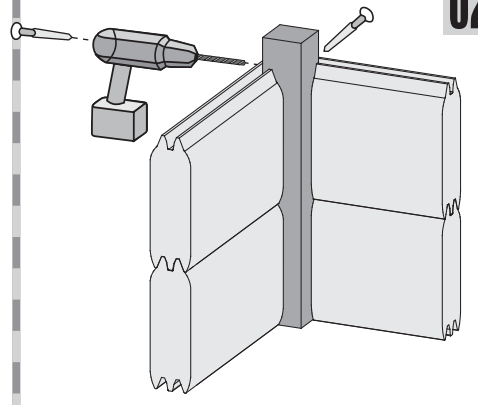



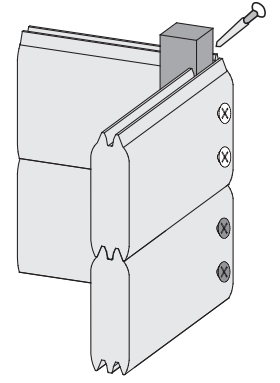

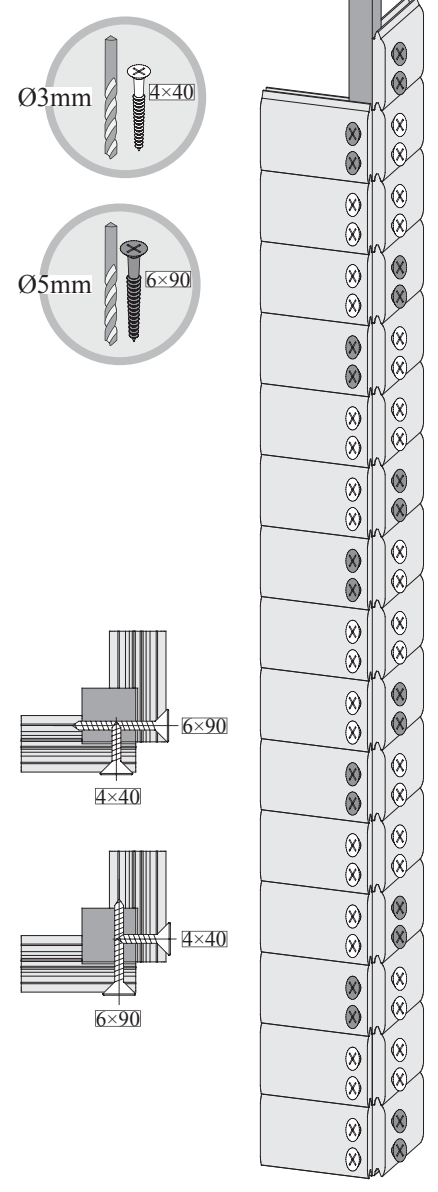

02.2



02.3



 Achten Sie auf die gleiche Höhe
 Look for the same height
 Faites attention à la même hauteur
 Besteed aandacht aan de dezelfde hoogte

 Prestar atención a la misma altura
 Prestare attenzione alla stessa altezza
 Dávejte pozor na stejnou výšku

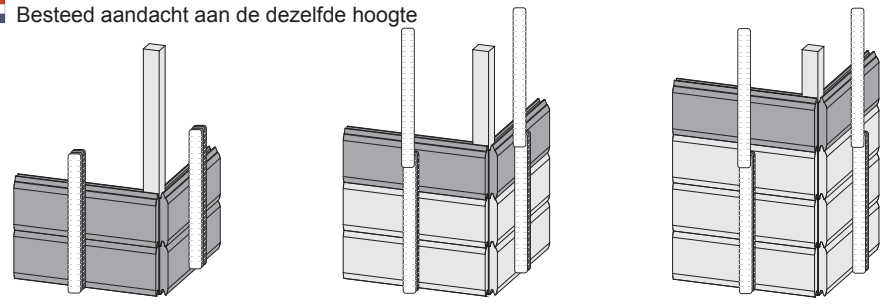

02

(02.1 + 02.2 → 02.3)

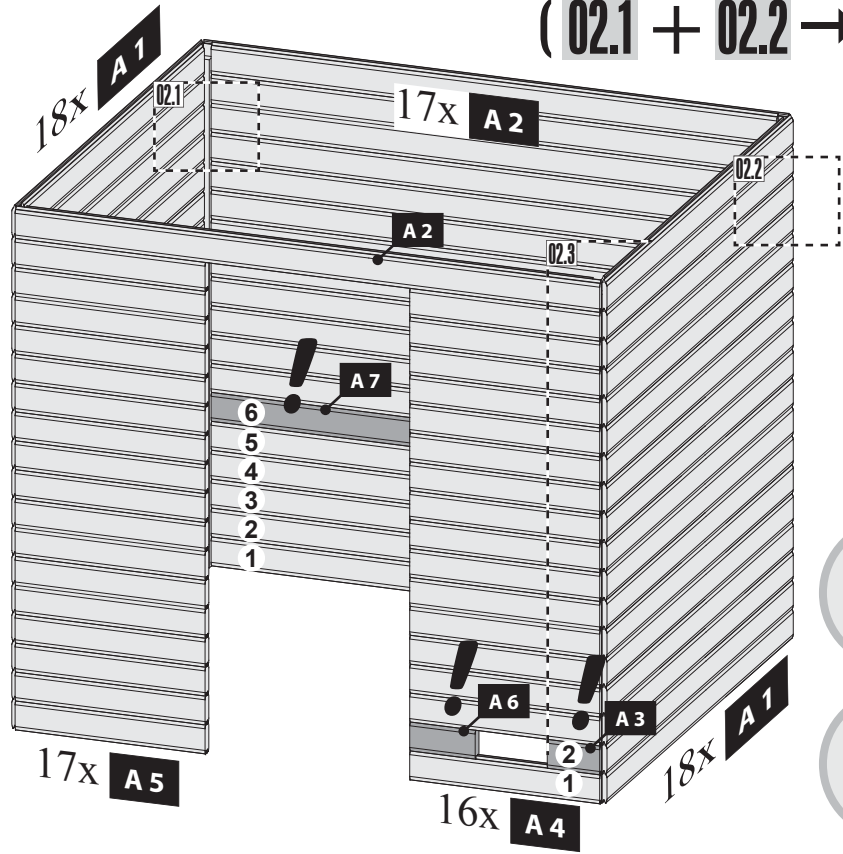



 138x

 66x

03

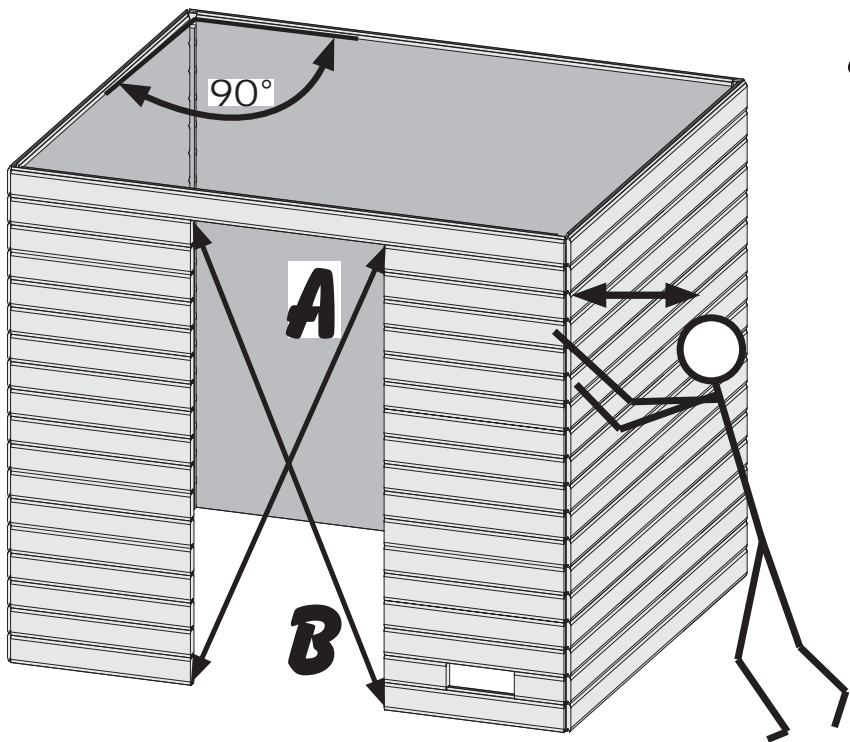
!!! A=B !!!



04

2x

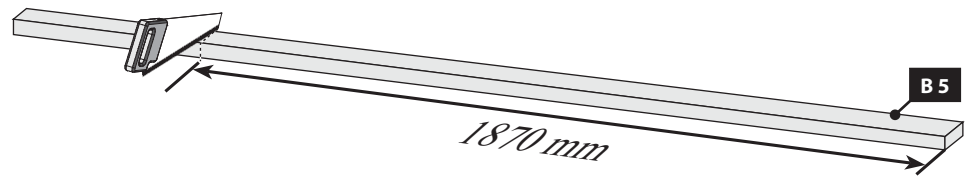

05

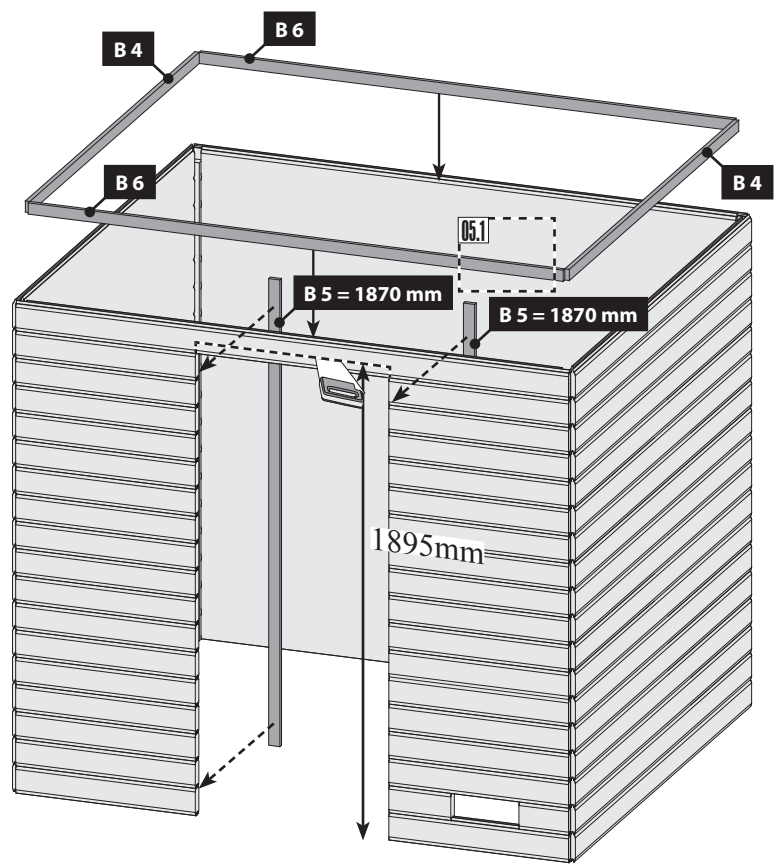

05.1

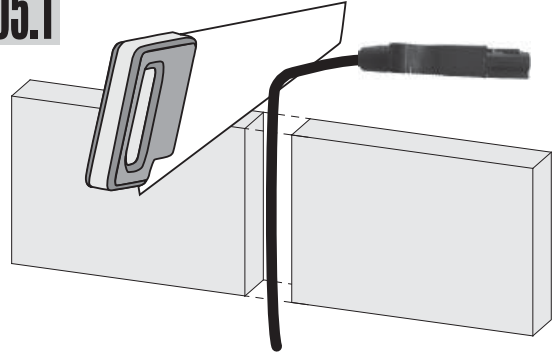

06

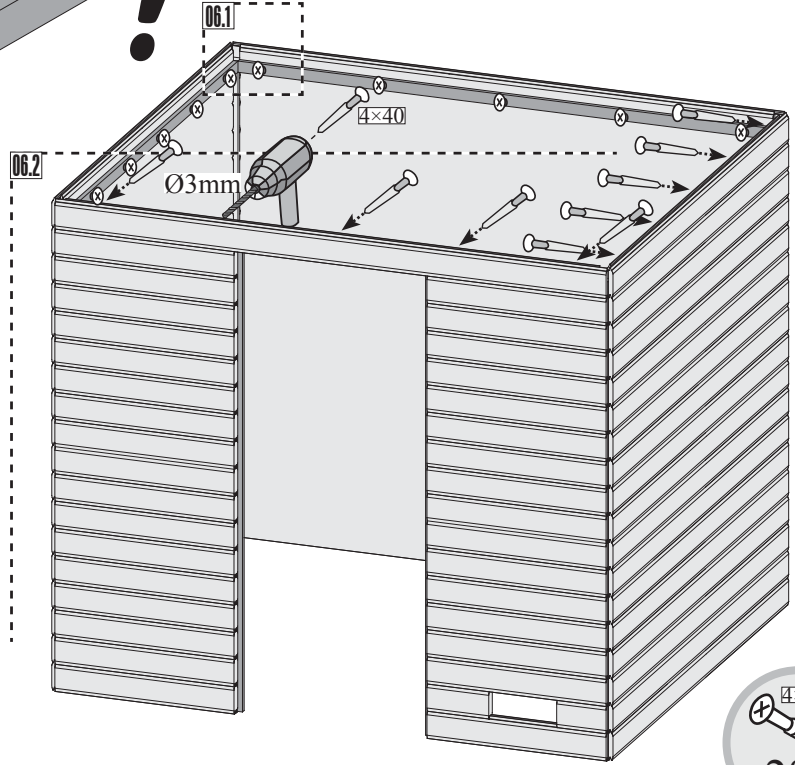
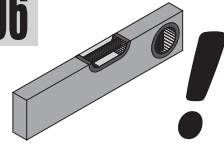

06.1

Bündig!
Affleurement!
Gelijk!
Aras!
Flush!
Combacia!
Stejný!

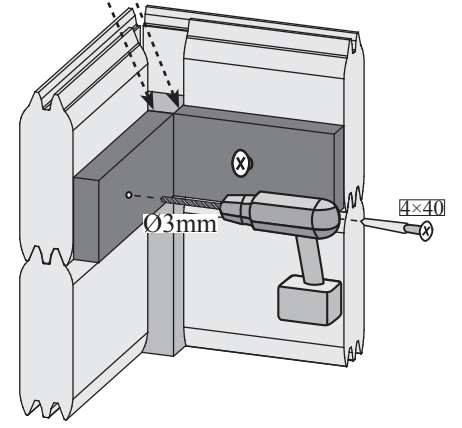

06.2

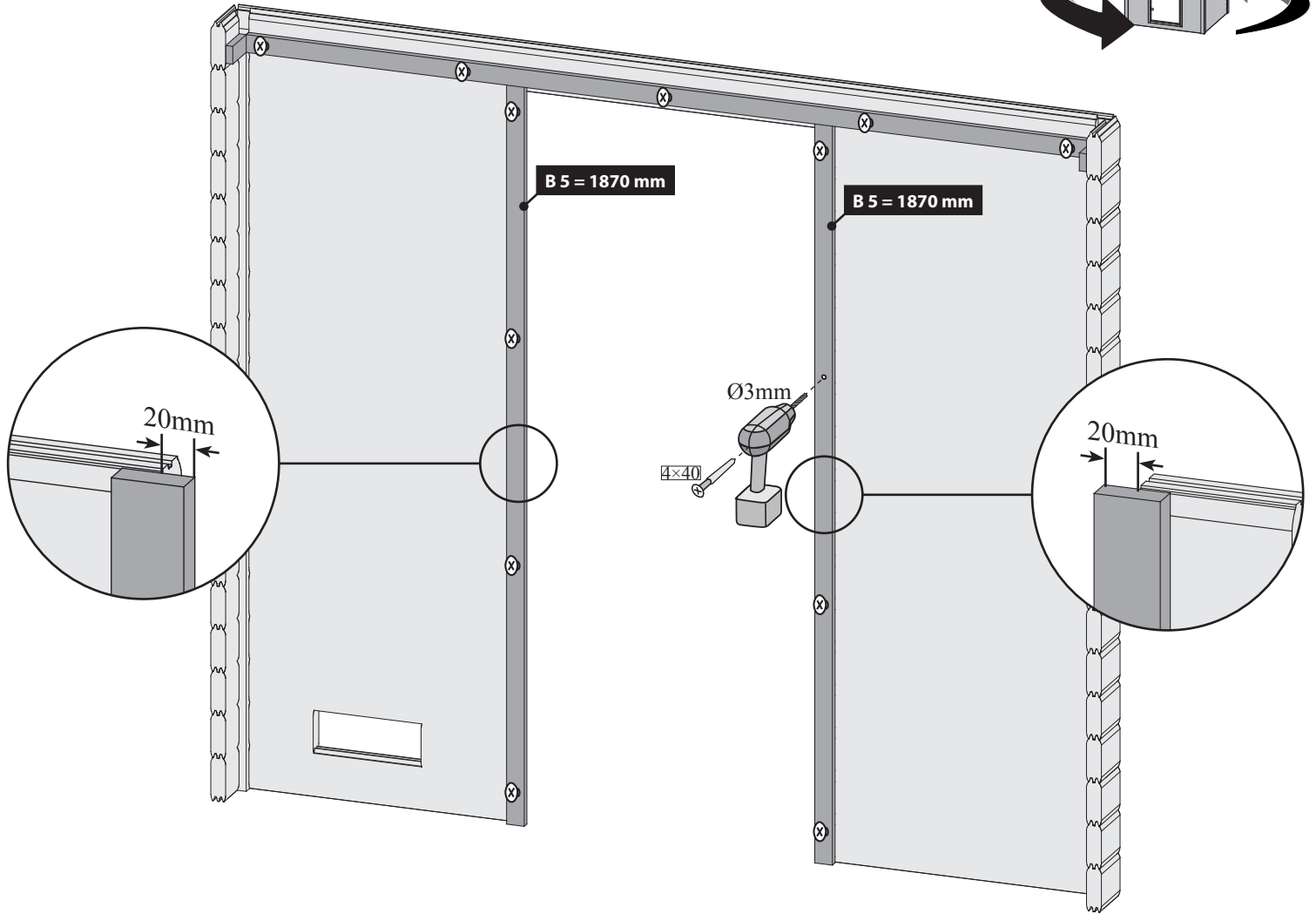
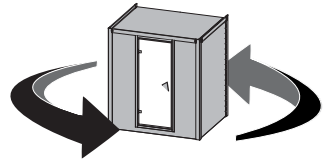

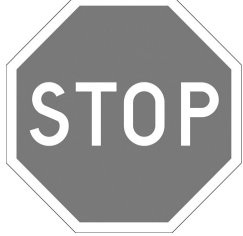

Einbau Glastür

Installation of glass door

Montaje de la puerta de cristal

Montage porte en verre

Montage van de glazen deur

Installazione portello di vetro

!!! 01 – 03 !!!

07

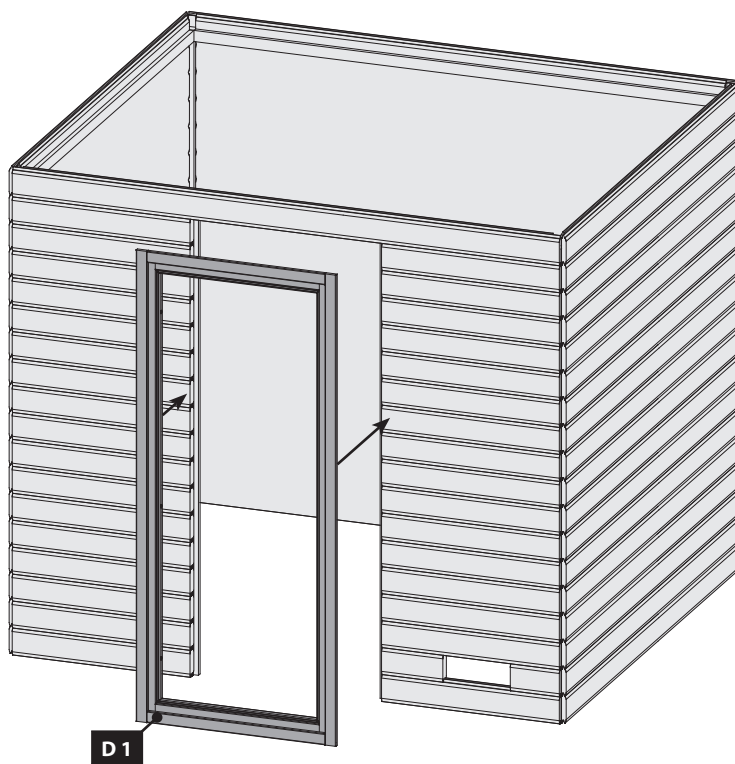

08

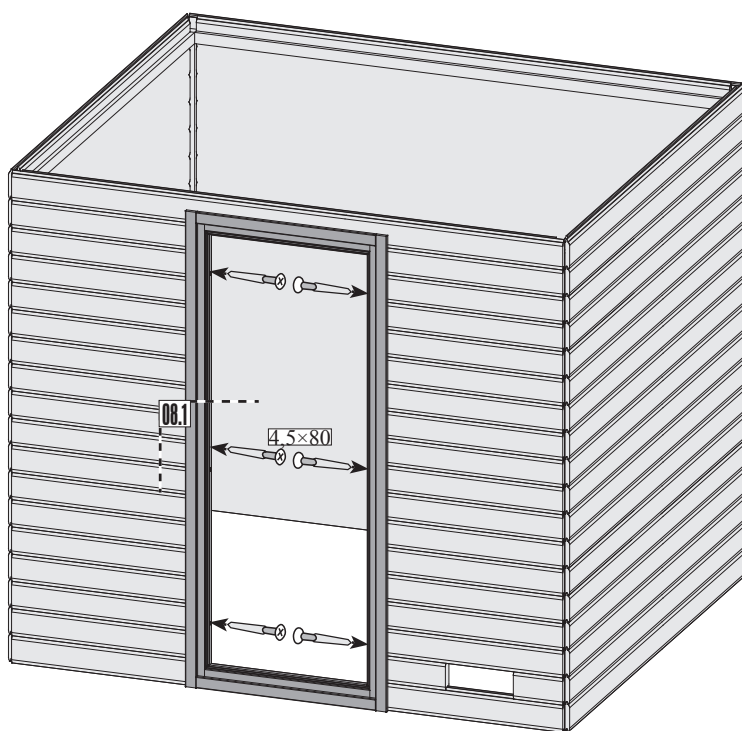

08.1-1

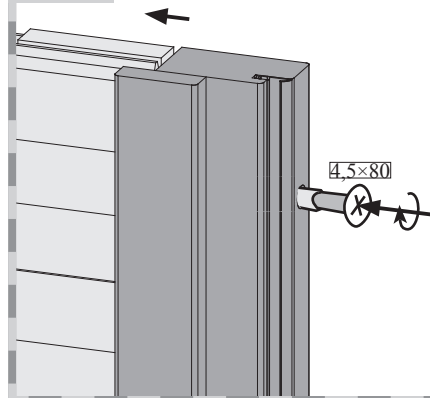

08.1-2

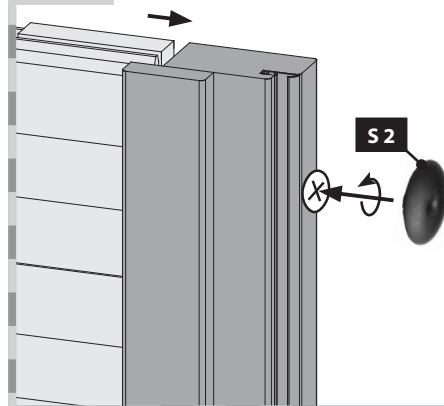

09

09.1

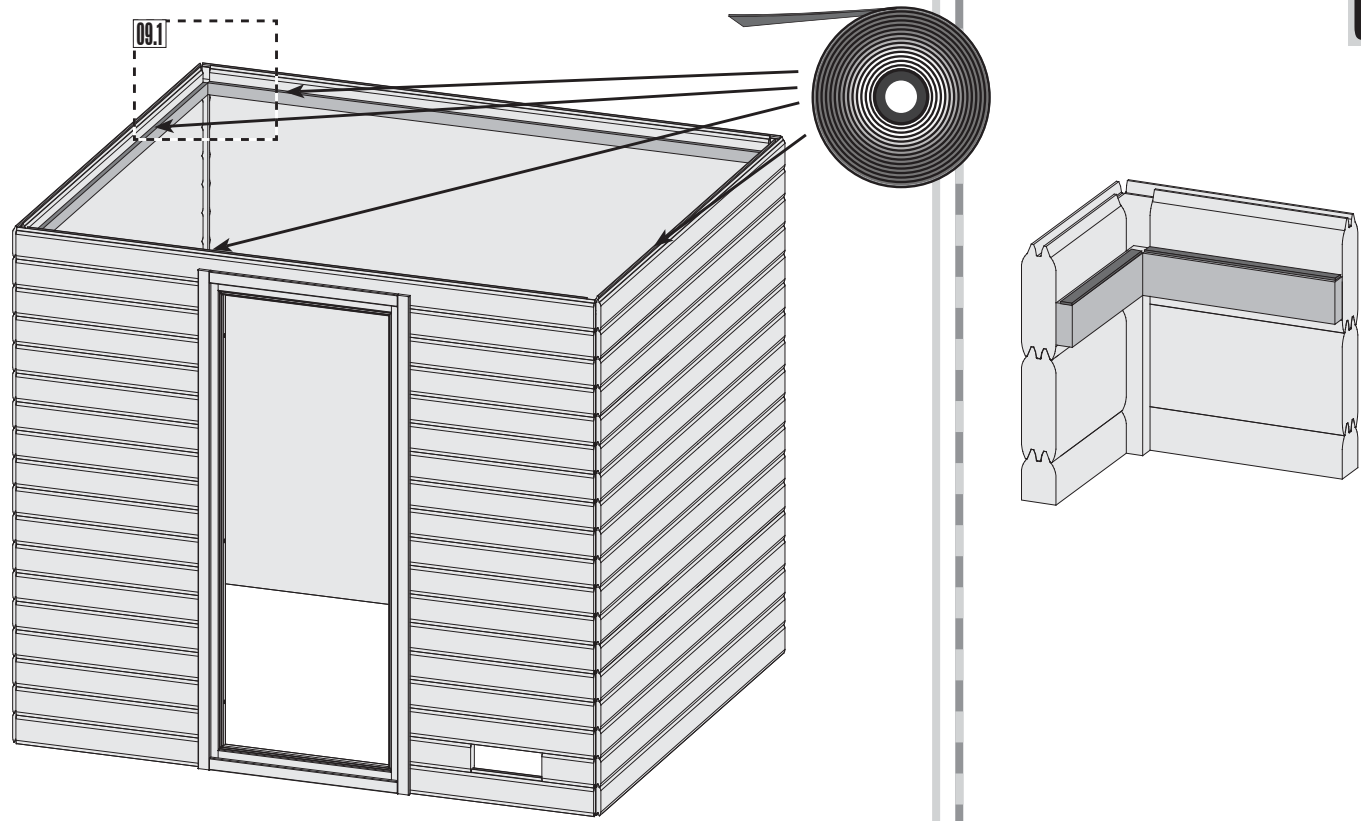

10

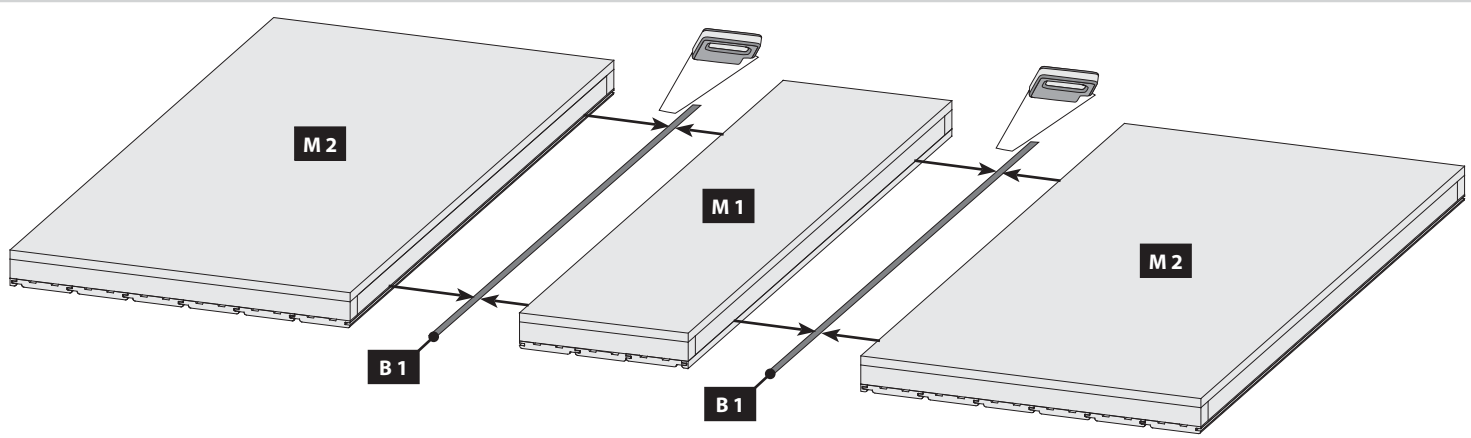

11

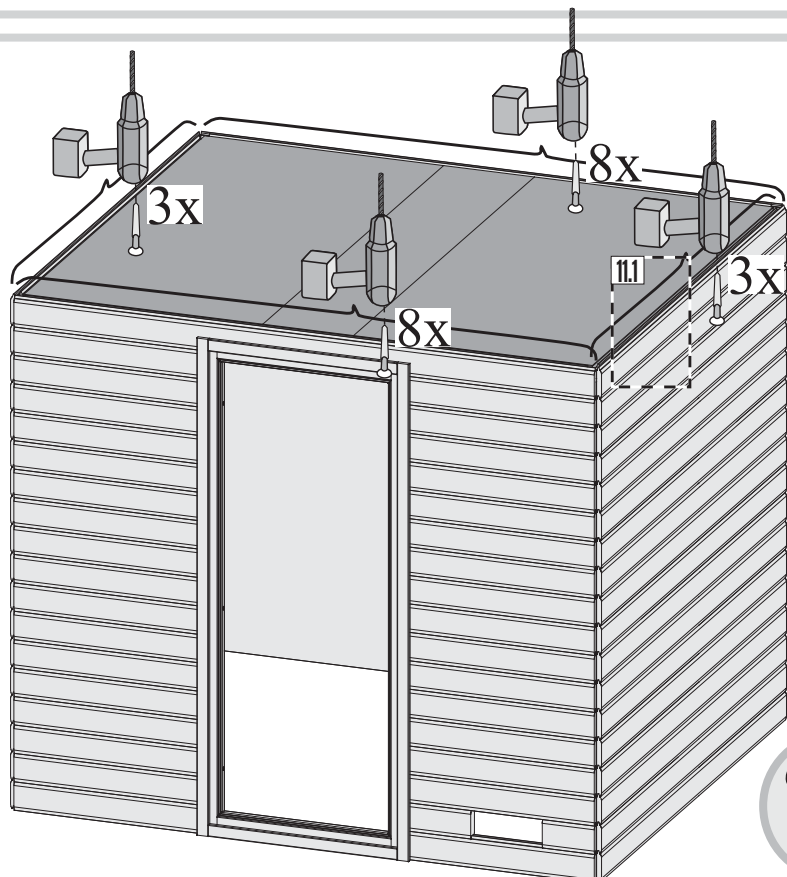

11.1

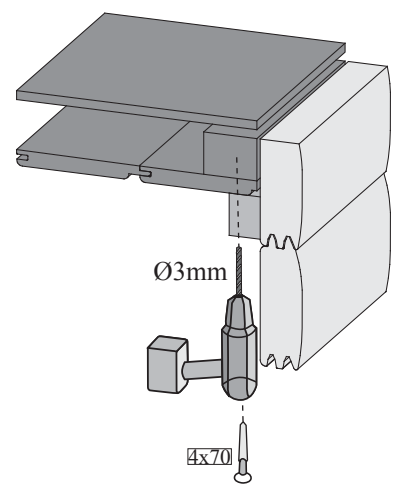

12 2x

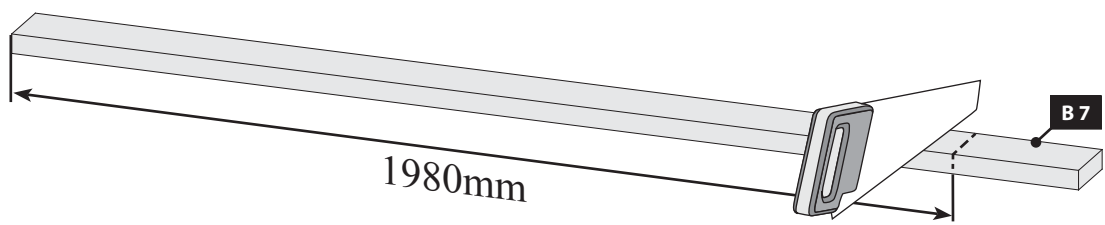

13 4x

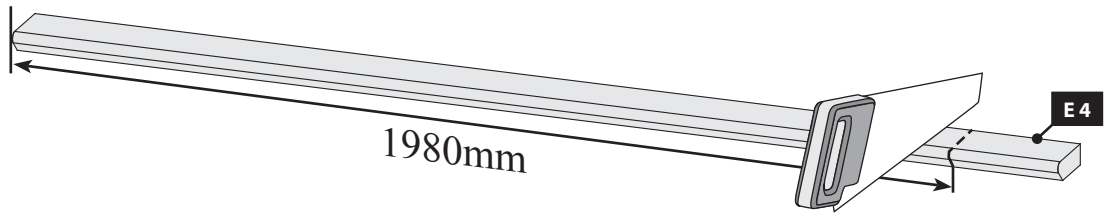

14

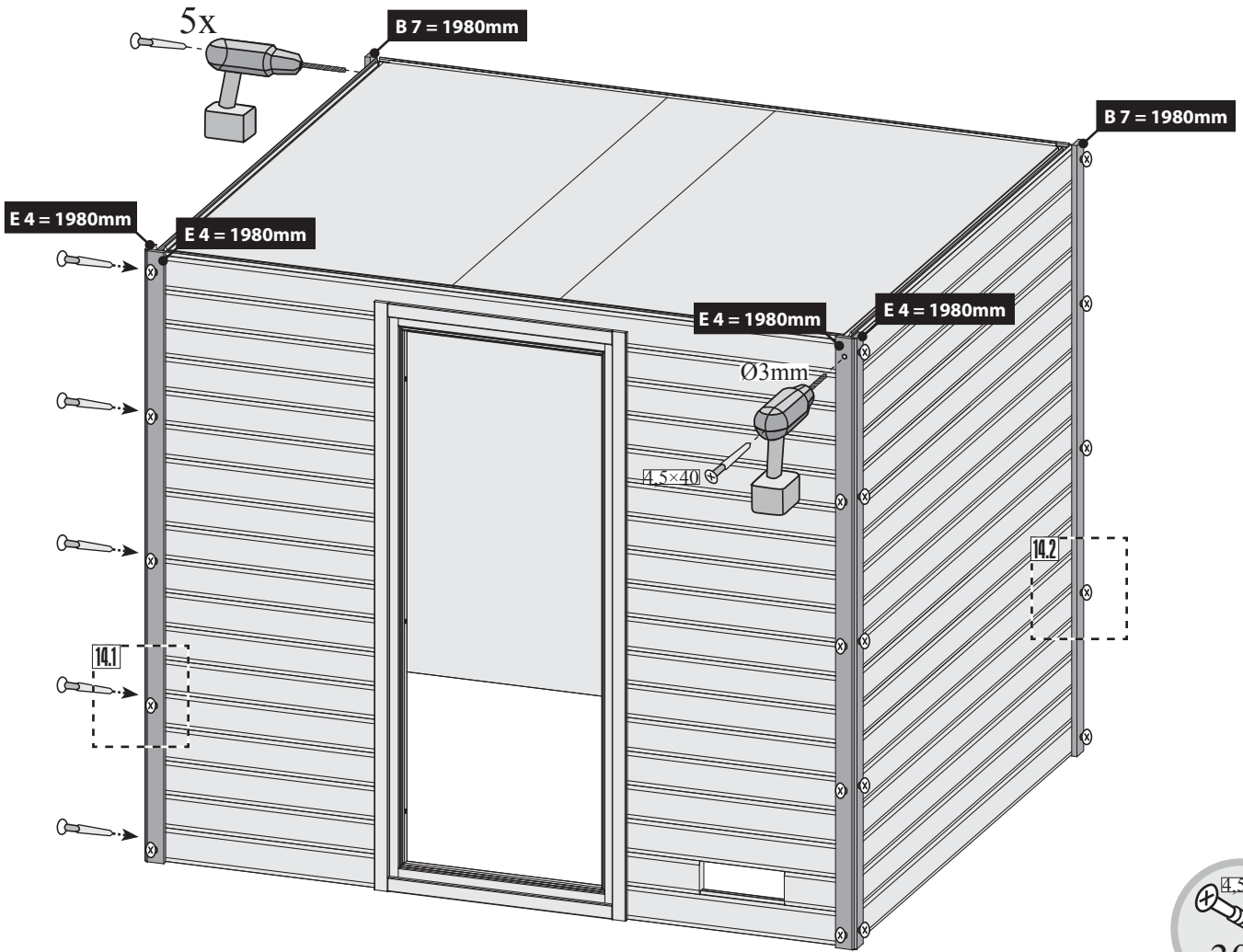

14.1

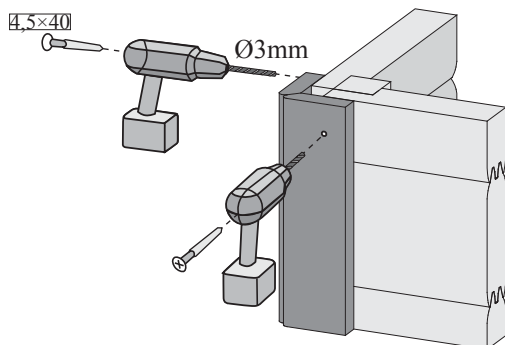

14.2

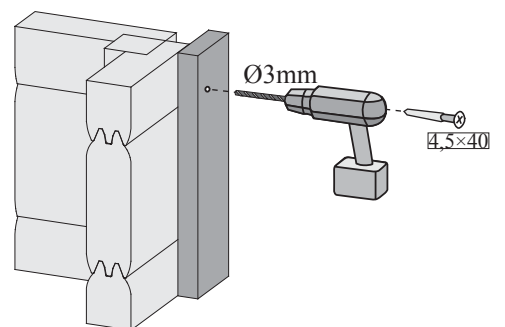

15

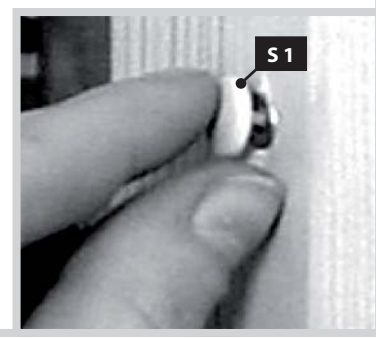
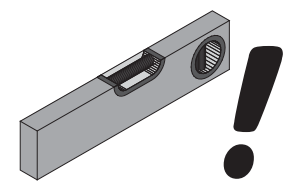
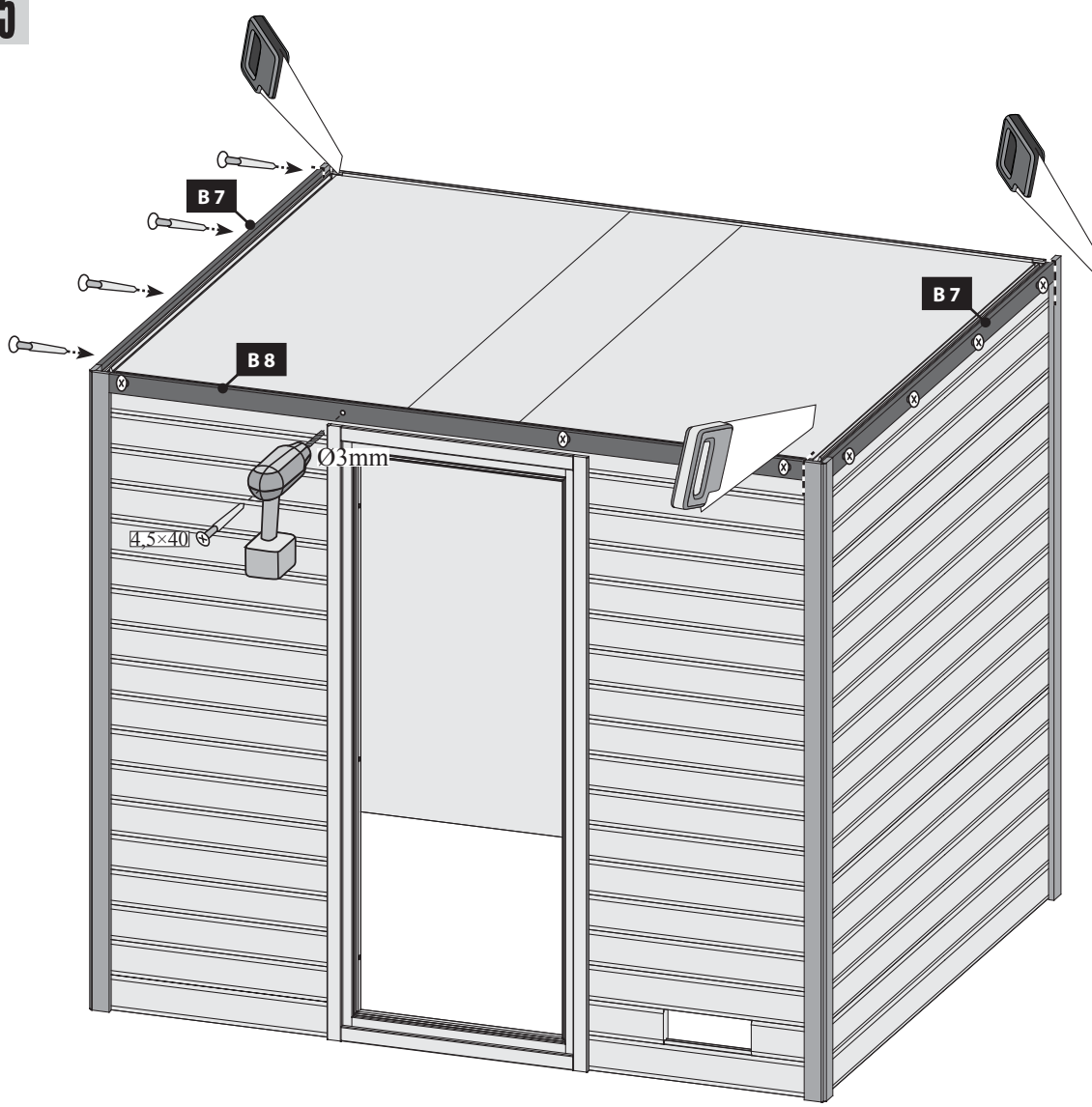

16 2x

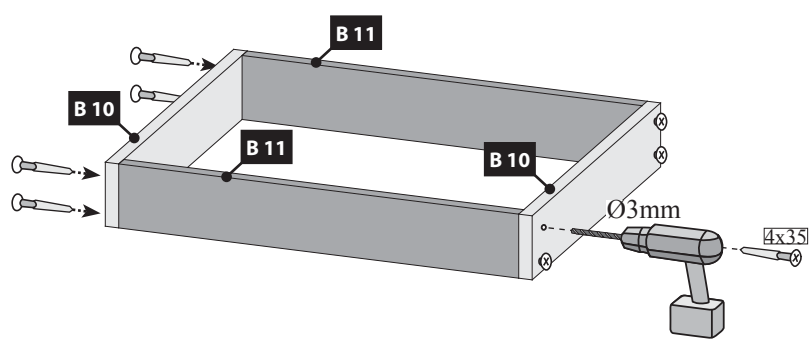

17 a

-  Nur bei 9 kW-Ofen
-  Seulement 9 kW chauffe
-  Only 9 kW heater
-  Slechts 9 kW heater
-  Sólo calentador de 9 kW
-  Solo riscaldamento 9 kW
-  Pouze topné těleso 9 kW

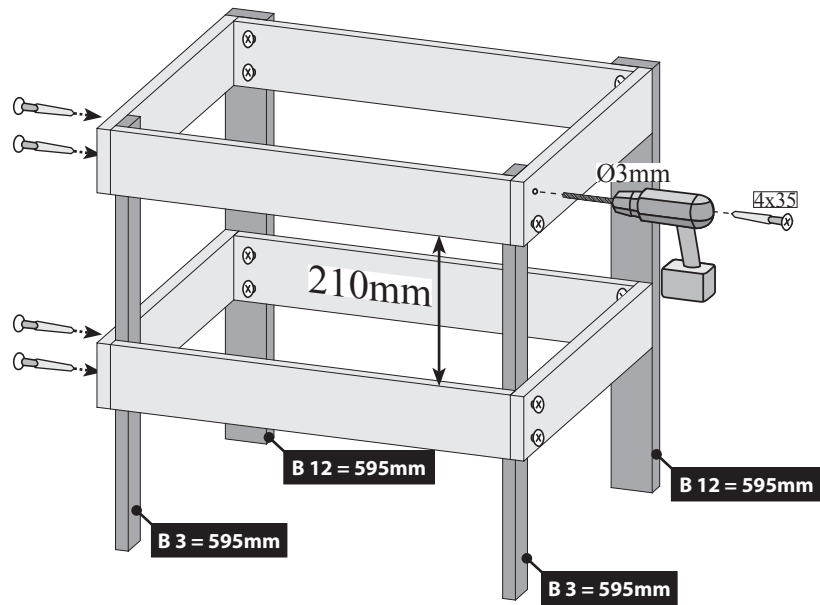
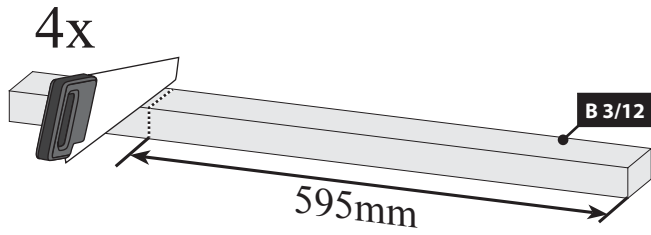

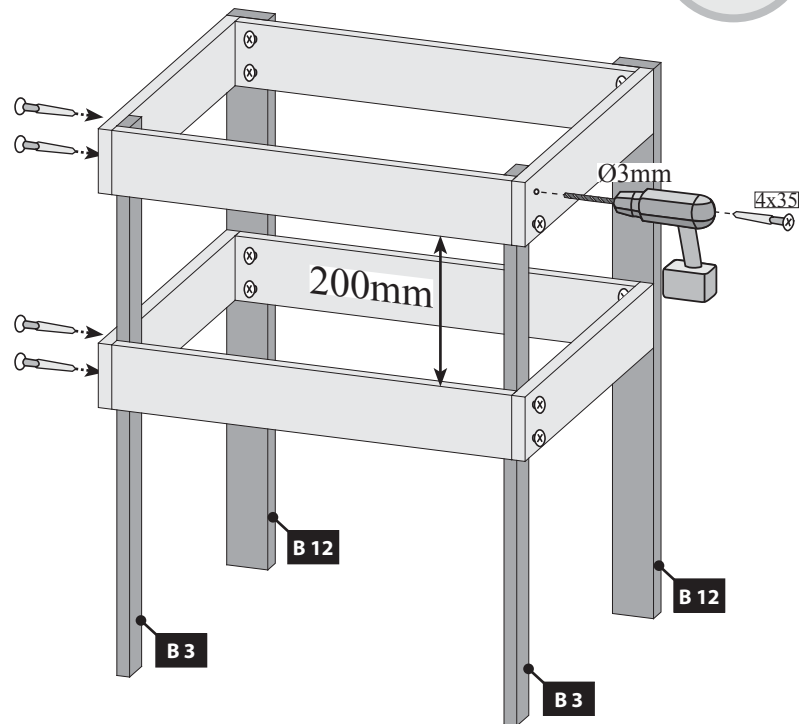

17 b

-  Bei allen anderen Öfen
-  Pour tous les autres fours
-  For all other furnaces
-  Voor alle andere ovens
-  Para todos los otros hornos
-  Per tutti gli altri tipi di forni
-  U všech ostatních pecích

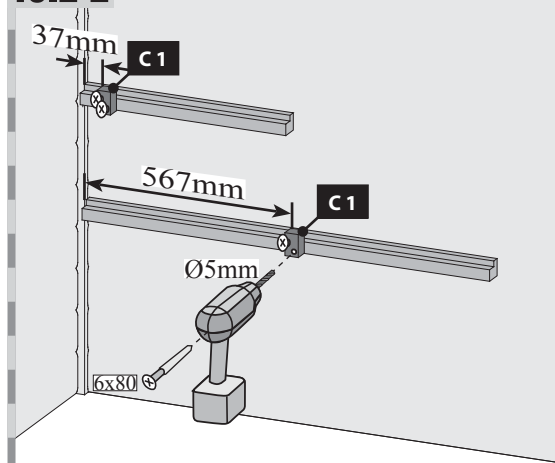
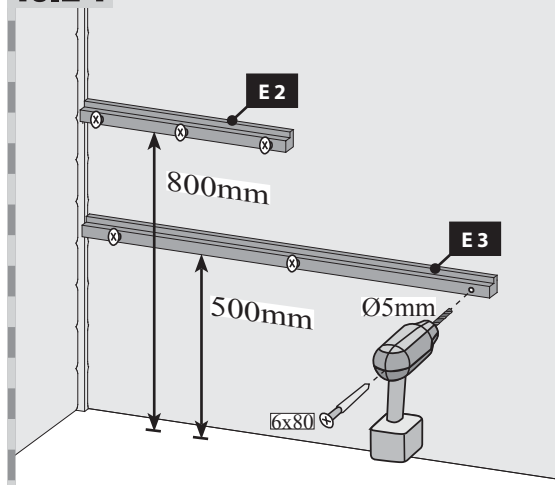
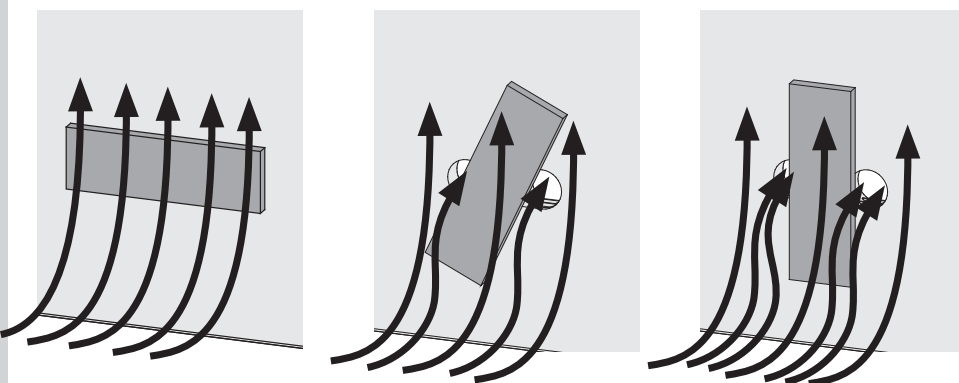
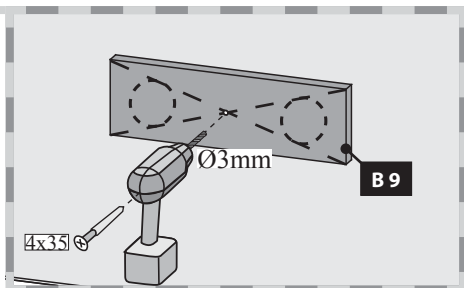
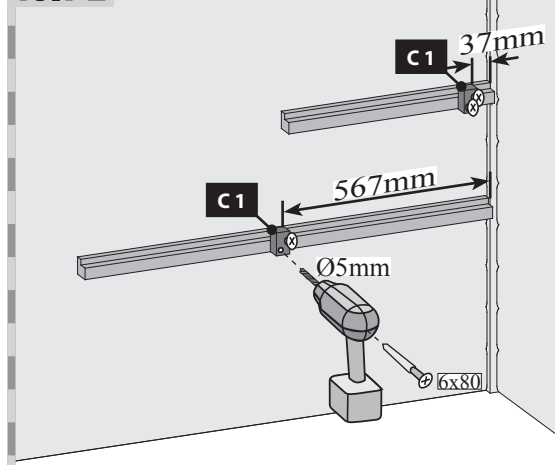
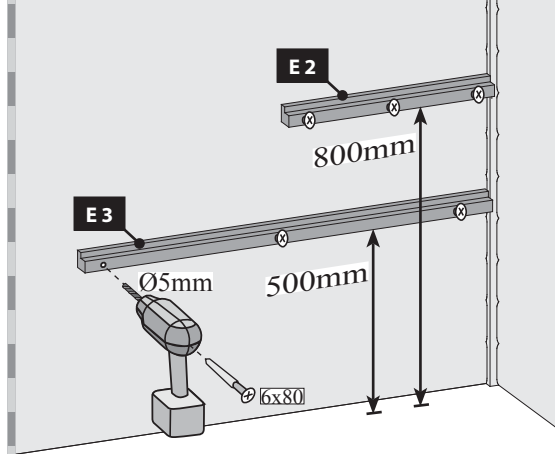
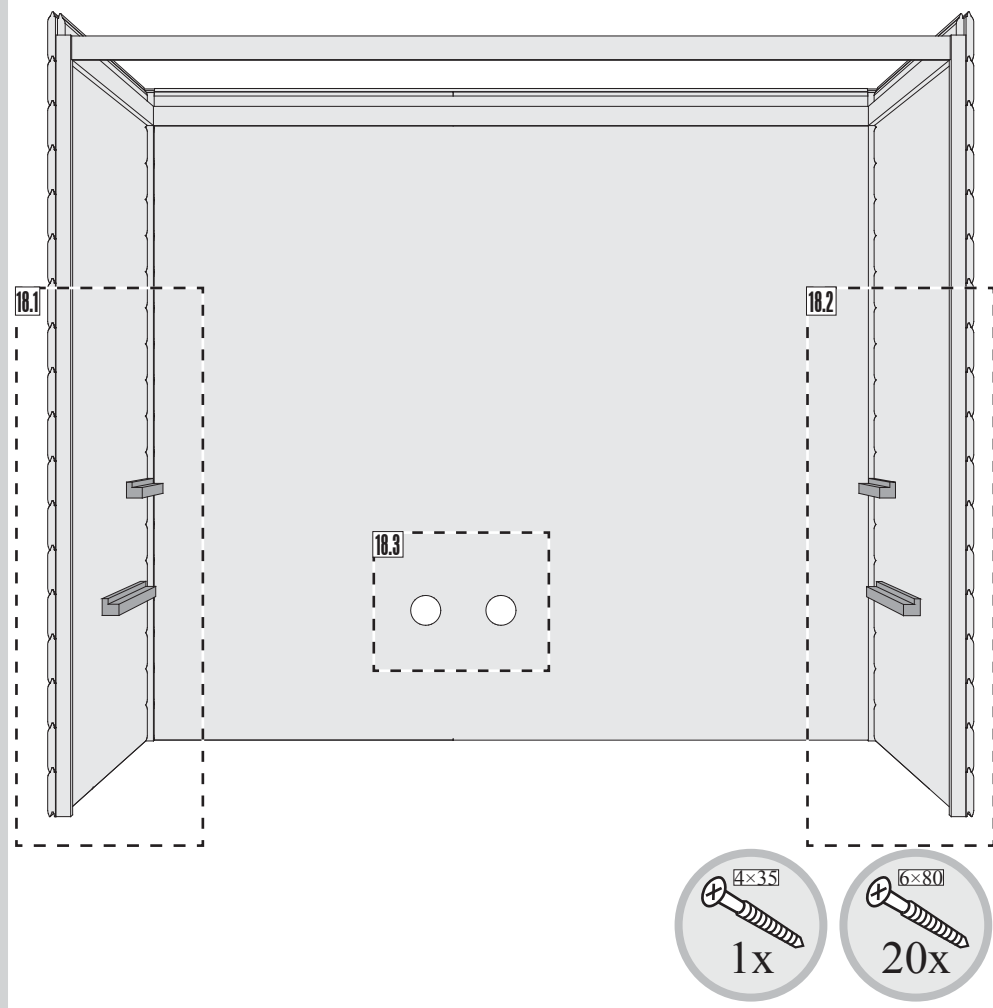





 Hier ist die Funktionsweise des Brettes abgebildet. Regeln Sie damit die Abluft nach Ihren eigenen Wünschen.

 Ceci représente le mode de fonctionnement de la planche. Avec elle, réglez l'écoulement de l'air selon vos désirs.

 This figure shows the functional principle of the board. Regulate the exhaust air according to your own wishes.

 Hier is de werking van het plankje afgebeeld. Regel daarmee de luchtafvoer naar eigen wens.

 Aquí está representada la forma de funcionamiento de la tabla. Regule con ello el aire de salida según sus propios deseos.

 Viene illustrato il principio di funzionamento della tavoletta di regolazione della ventilazione. Con essa si può regolare a piacere la ventilazione.

 Zde je zobrazená funkce desky. Regulujte s ní odsávací vzduch dle Vašeho přání.

19 2x

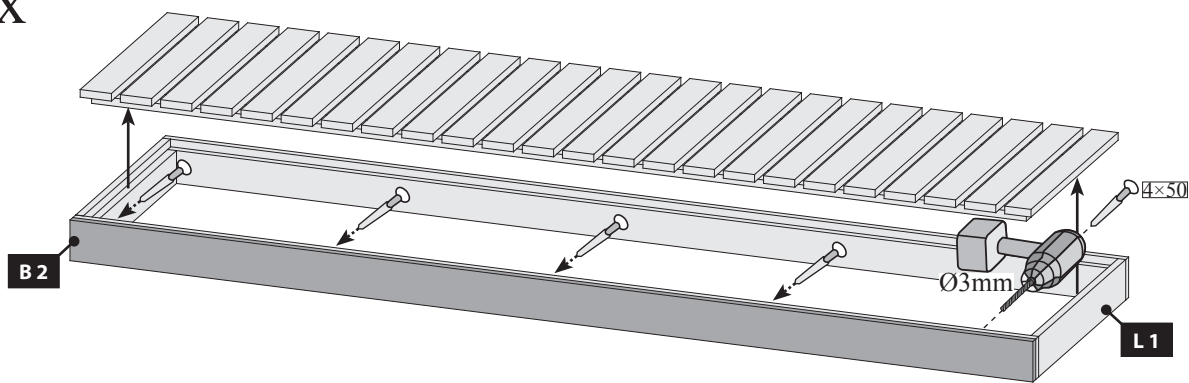

20

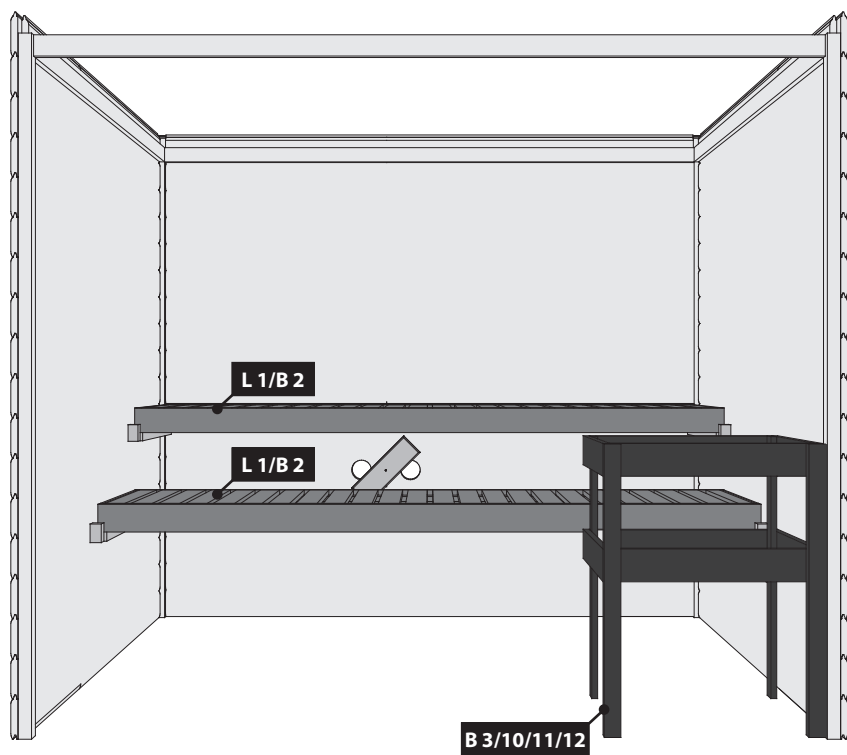

21

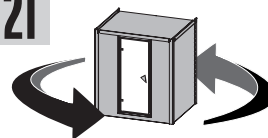

Bündig!
Affleurement!
Gelijk!
Aras!
Flush!
Combacia!
Stejný!

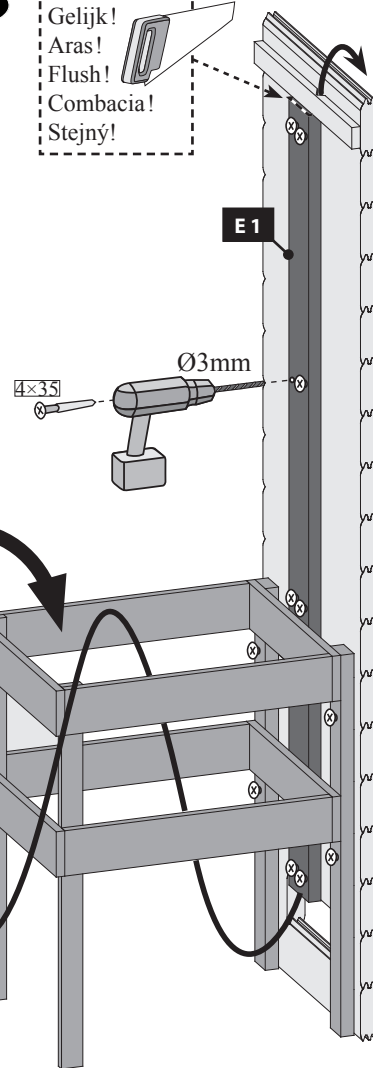

 Einbau Saunatür

 Sauna deur installatie

 Sauna Instalace dveře

 Sauna door installation

 Instalación de la puerta Sauna

 Installation de porte Sauna

 Installazione porta Sauna

