

79773 81126

**Aufbauanleitung****notice de montage****Building Instructions****montagehandleiding****Instrucciones de construcción****Istruzioni per il montaggio****Montážní návod****Service-Hotline: +49 421 38693 33**

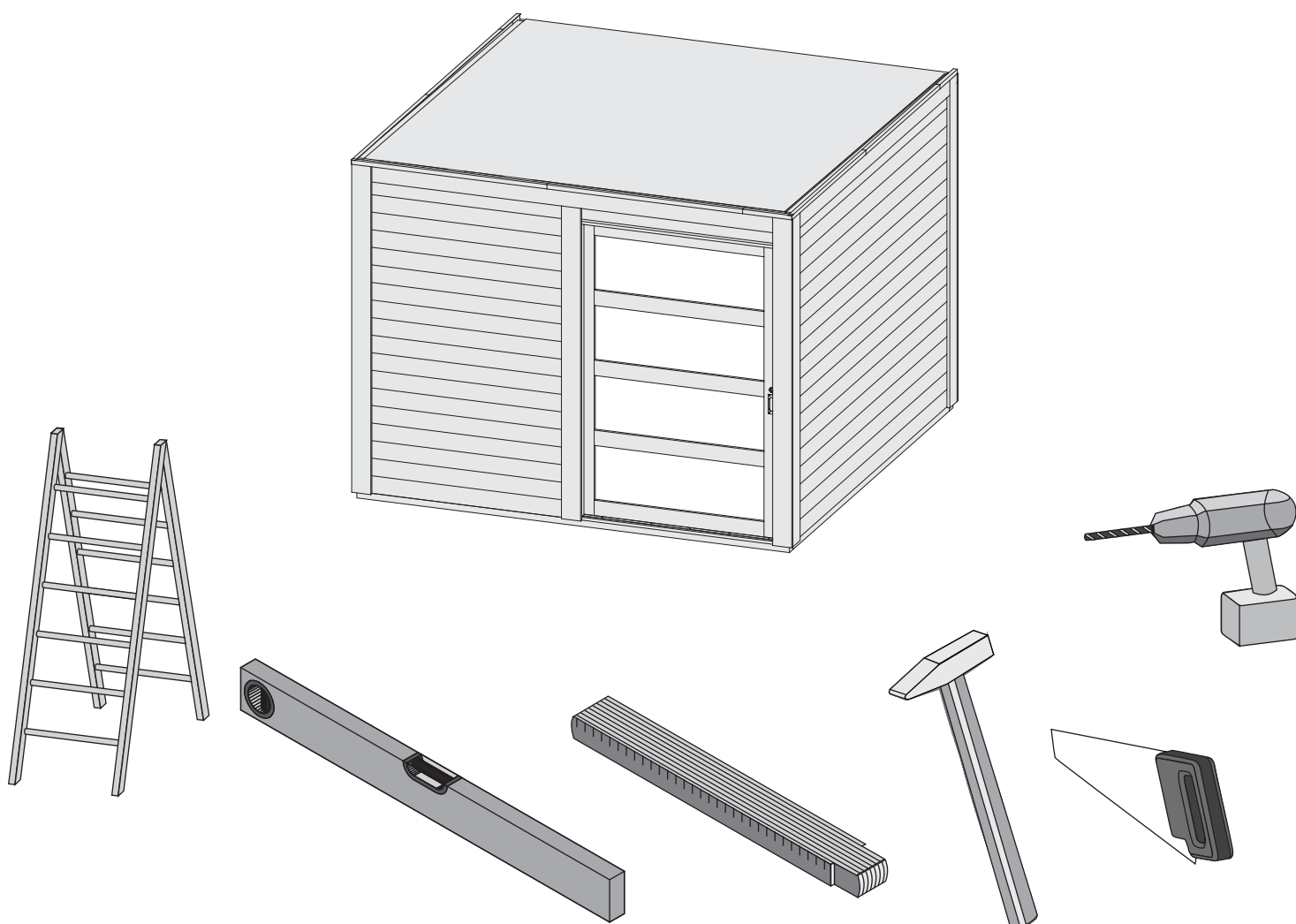

Vergleichen Sie zuerst die Material-liste mit Ihrem Paketinhalt! Bitte haben Sie Verständnis, dass Beanstandungen nur im nicht aufgebauten Zustand bearbeitet werden können!



En primer lugar, compare la lista de material con el contenido del paquete. Rogamos entienda que las reclamaciones sólo pueden ser tramitadas antes de montar el objeto!



Nejprve přezkontrolujte obsah balení podle materiálového listu! Mějte pochopení pro to, že případnou reklamaci se můžeme zabývat pouze tehdy, když díly nebudou smontované! Za pomoci tohoto seznamu můžete jednotlivé díly přiřadit k montážnímu návodu.



Vergelijk eerst de lijst van materialen met de inhoud van uw pakket! Reclamaties kunnen alleen in behandeling worden genomen zolang de onderdelen nog niet zijn gemonteerd!



First compare the list of materials with your package contents! Please understand that complaints can be processed in the non-built status only!



Commencez par comparer la liste du matériel avec le contenu de votre paquet! Sachez que nous traitons uniquement les réclamations concernant le matériel à l'état non monté!



Confrontate questa distinta materiali prima con il contenuto del pacchetto! Vi preghiamo di comprendere che eventuali reclami possono essere accolti solo prima del montaggio!

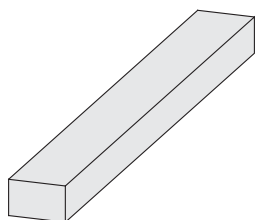
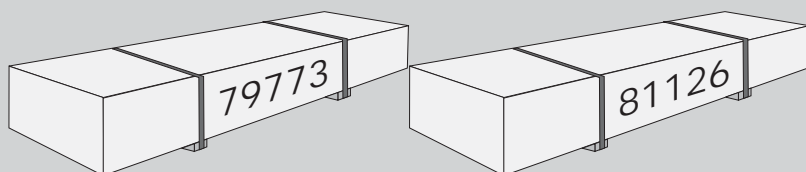

2 x B1	1920 x	20 x	3 mm	ID 20799
1 x B2	1205 x	18 x	14 mm	ID 80903
1 x B3	1309 x	90 x	16 mm	ID 72925
2 x B4	2156 x	90 x	16 mm	ID 71514
1 x B5	1205 x	36 x	18 mm	ID 72613
1 x B6	1205 x	36 x	18 mm	ID 80905
1 x B7	780 x	36 x	18 mm	ID 65721
2 x B8	800 x	45 x	18 mm	ID 24796
3 x B9	2100 x	45 x	18 mm	ID 19547
1 x B10	300 x	95 x	18 mm	ID 19130
4 x B11	480 x	95 x	18 mm	ID 20930
4 x B12	565 x	95 x	18 mm	ID 15498
9 x B13	2060 x	120 x	18 mm	ID 80904
3 x B14	2520 x	120 x	18 mm	ID 80895
9 x B15	2650 x	140 x	26 mm	ID 16086
2 x B16	1756 x	38 x	28 mm	ID 20699
2 x B17	2560 x	38 x	28 mm	ID 80906
2 x B18	800 x	58 x	28 mm	ID 15493
1 x B19	1854 x	58 x	38 mm	ID 79823
1 x B20	1854 x	84 x	38 mm	ID 79824
8 x B21	2790 x	60 x	40 mm	ID 28251
9 x B22	2040 x	45 x	45 mm	ID 80896
1 x B23	2560 x	45 x	45 mm	ID 84955

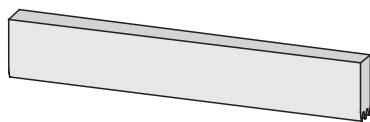

1 x V1	2650 x	96 x	38 mm	ID 80908
1 x V2	2650 x	96 x	38 mm	ID 80909

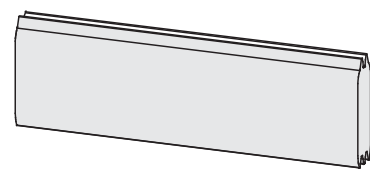

2 x W1	327 x	121 x	38 mm	ID 16340
31 x W2	932 x	121 x	38 mm	ID 80893
17 x W3	1322 x	121 x	38 mm	ID 80892
60 x W4	2650 x	121 x	38 mm	ID 70229

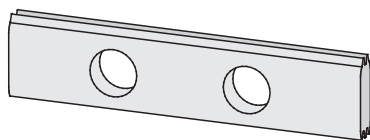

1 x W5	2650 x	121 x	38 mm	ID 80907
--------	--------	-------	-------	----------

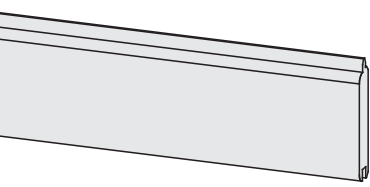

60 x R1	2650 x	96 x	19 mm	ID 63990
---------	--------	------	-------	----------

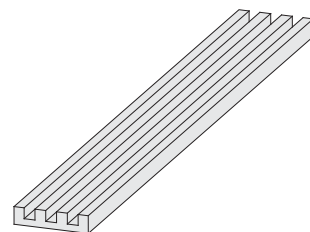

1 x E1	1820 x	110 x	26 mm	ID 26480
--------	--------	-------	-------	----------

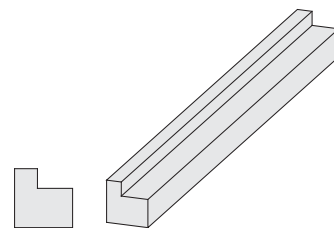

2 x L1	555 x	45 x	45 mm	ID 40301
2 x L2	1100 x	45 x	45 mm	ID 40302

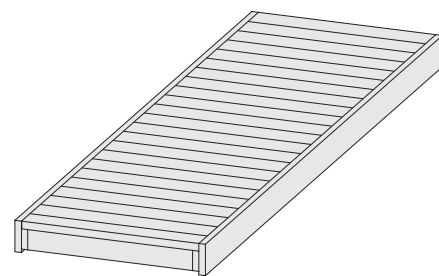

1 x L3	1810 x	550 x	90 mm	ID 43994
2 x L4	2010 x	550 x	90 mm	ID 80901

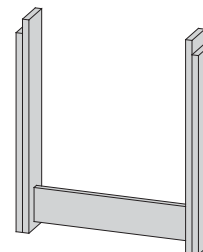

2 x L5	595 x	510 x	95 mm	ID 62992
1 x L6	860 x	510 x	95 mm	ID 65739

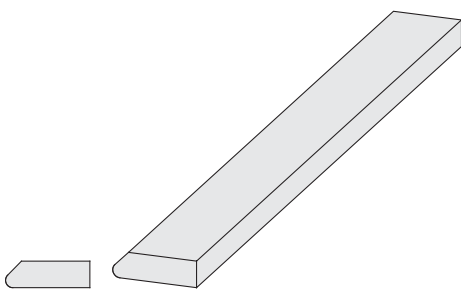

2 x G1	2000 x	58 x	17 mm	ID 48545
1 x G2	400 x	95 x	18 mm	ID 27167



1 x K1 | 1833 x 1255 x 19 mm | ID 79825

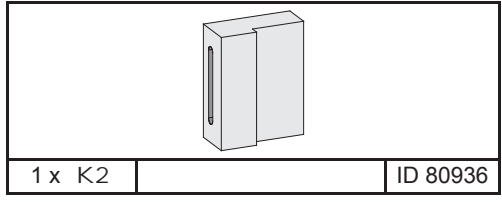

1 x K2 | | ID 80936

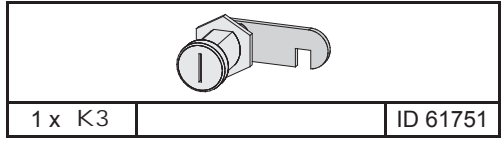

1 x K3 | | ID 61751

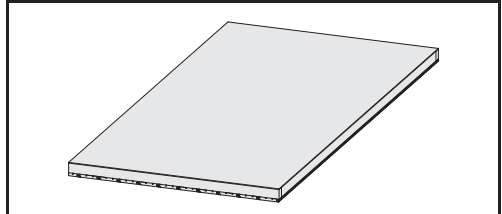

3 x R2 | 1839 x 880 x 55 mm | ID 80899

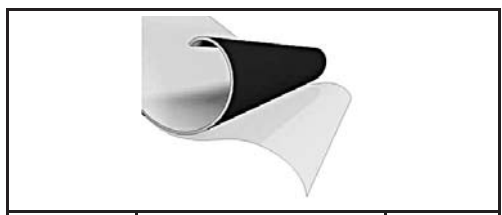

3 x S1 | | ID 77453

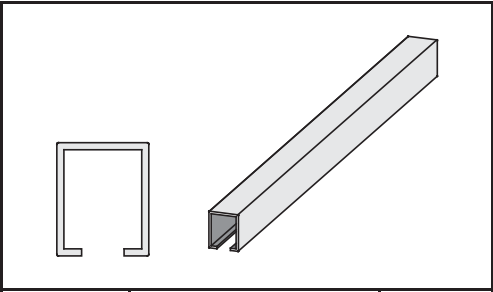

1 x A1 | | ID 80897

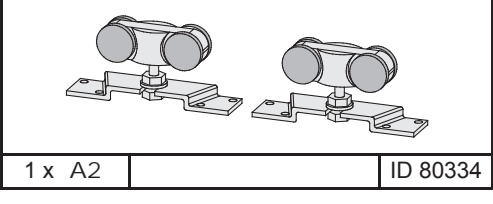

1 x A2 | | ID 80334

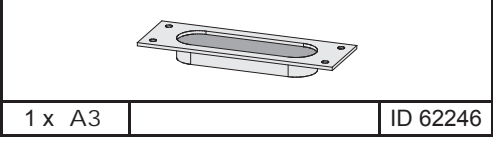

1 x A3 | | ID 62246

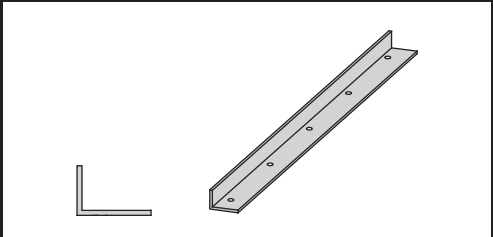

1 x A4 | | ID 80898

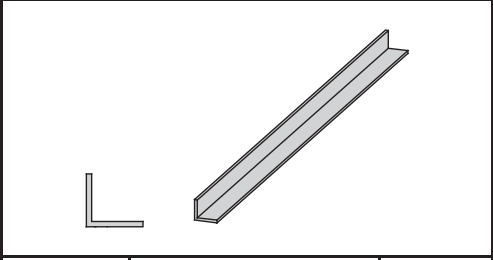

7 x A5 | | ID 79609

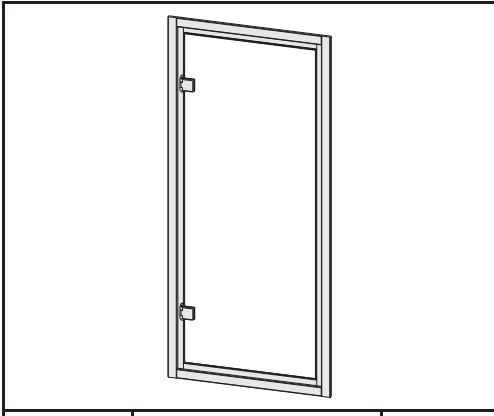

1 x D1 | 1796 x 815 x 38 mm | ID 66683

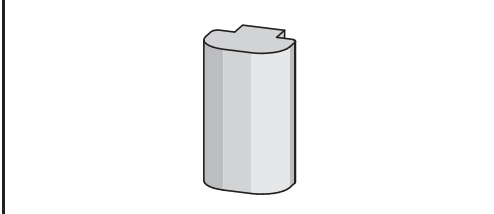

1 x D2 | | ID 26183

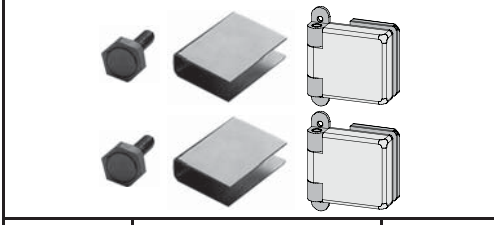

1 x D3 | | ID 26496

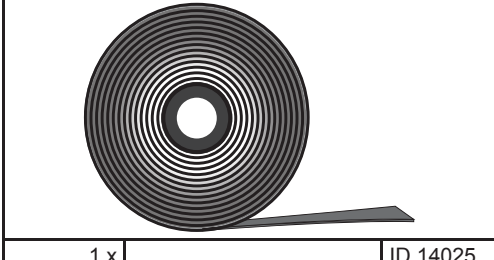

1 x | | ID 14025

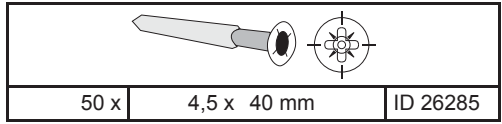

50 x | 4,5 x 40 mm | ID 26285



60 x | *wird nicht gebraucht* | ID 26116

6 x | | ID 46403

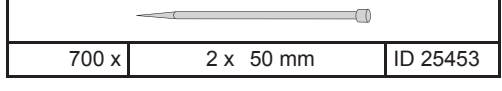

700 x | 2 x 50 mm | ID 25453

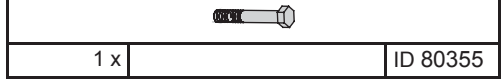

1 x | | ID 80355

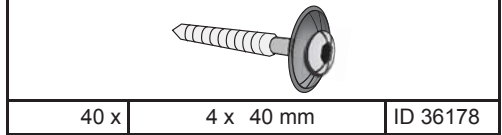

40 x | 4 x 40 mm | ID 36178

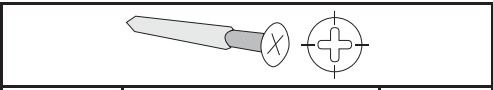

20 x | 4 x 30 mm | ID 3686

60 x | 4 x 35 mm | ID 3687

350 x | 4 x 40 mm | ID 21925

230 x | 4 x 50 mm | ID 3688

650 x | 4 x 70 mm | ID 3689

25 x | 4,5 x 80 mm | ID 9204

20 x | 6 x 60 mm | ID 14014

80 x | 6 x 90 mm | ID 26715

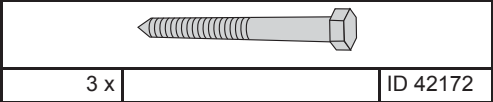

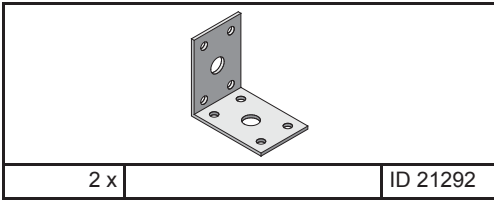

3 x | | ID 42172



2 x | | ID 21292

- ***
- Nicht im Lieferumfang enthalten
 - Niet bijgeleverd
 - Not included
 - Non comprises dans la livraison
 - No forman parte del suministro
 - Non incluso
 - V ceně není zahrnuto

 Draufsicht
 vue de dessus
 Top view

 bovenaanzicht
 vista desde arriba
 vista dall'alto

 pùdorys

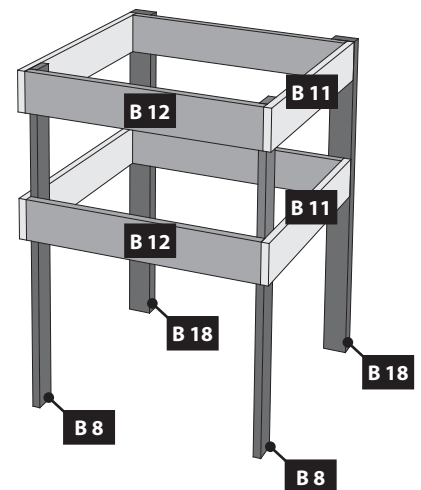
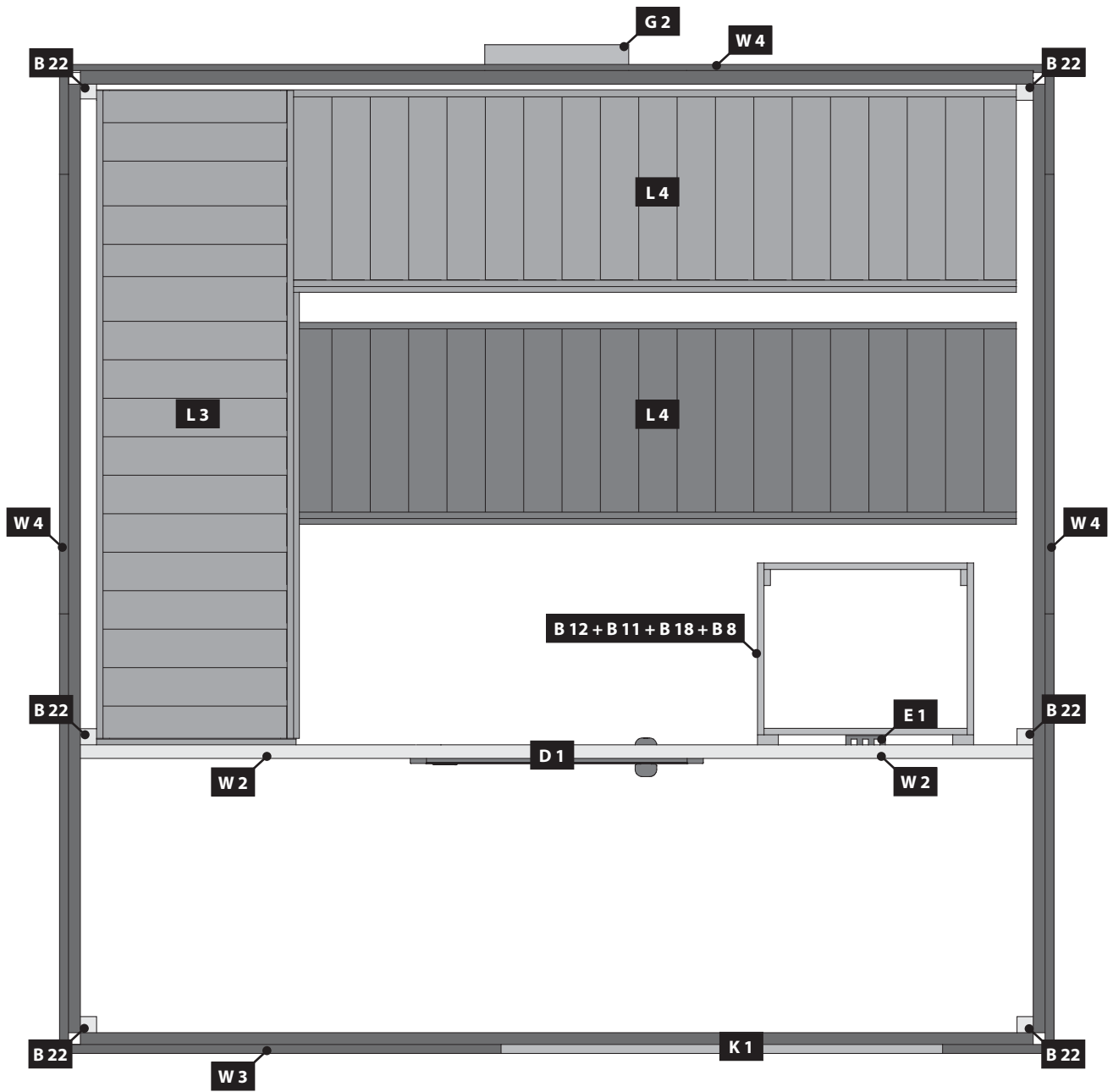

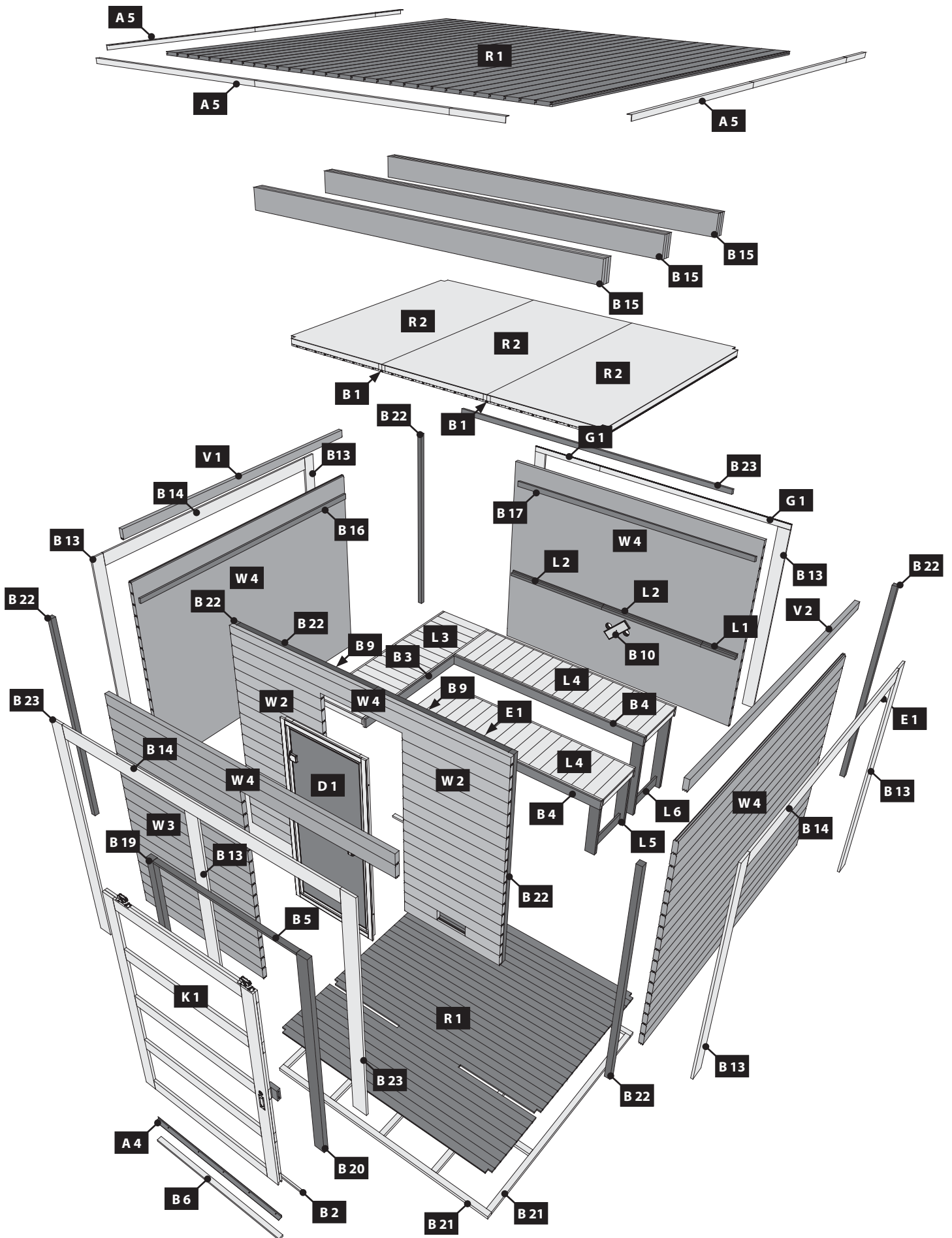

01 2x

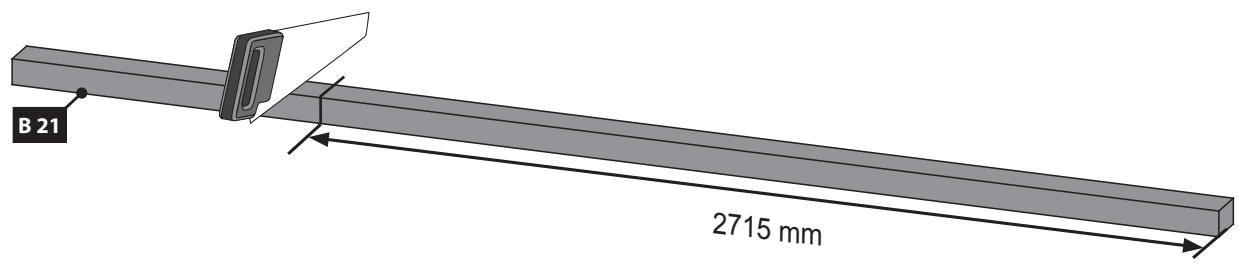

02 2x

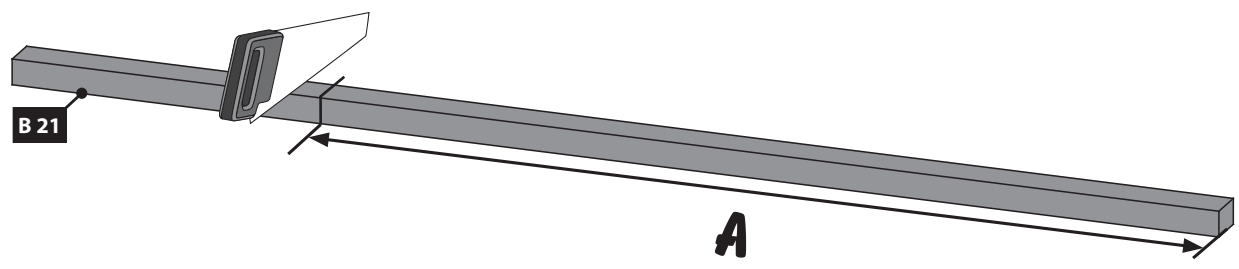

03

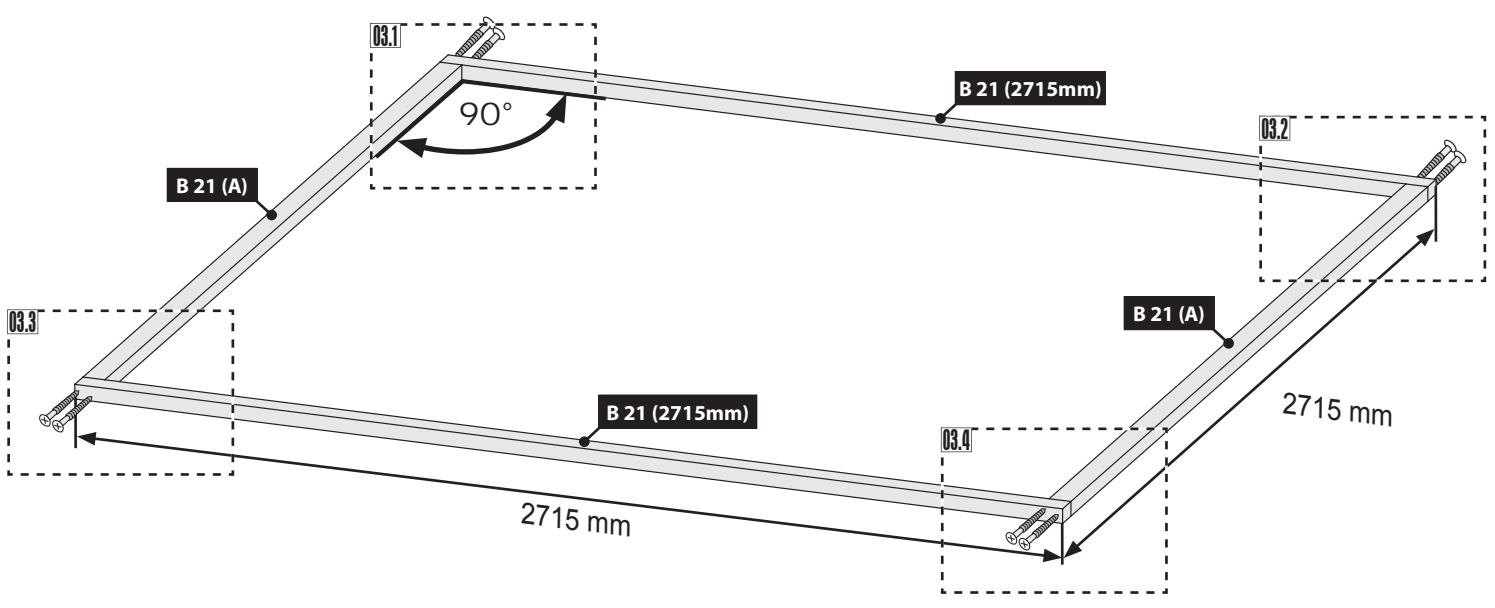
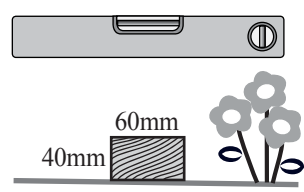

03.1

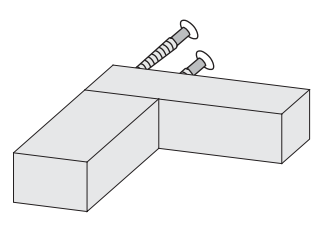
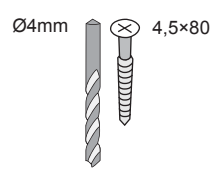

03.2

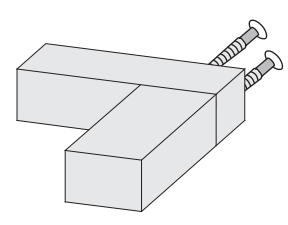
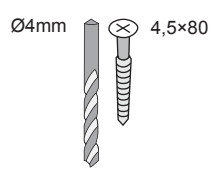

03.3

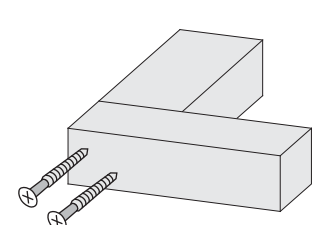
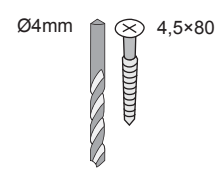

03.4

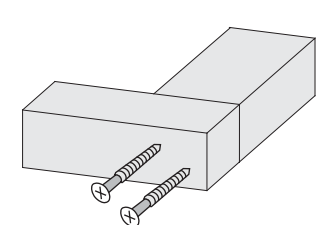
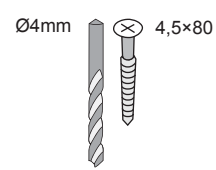

04 1x

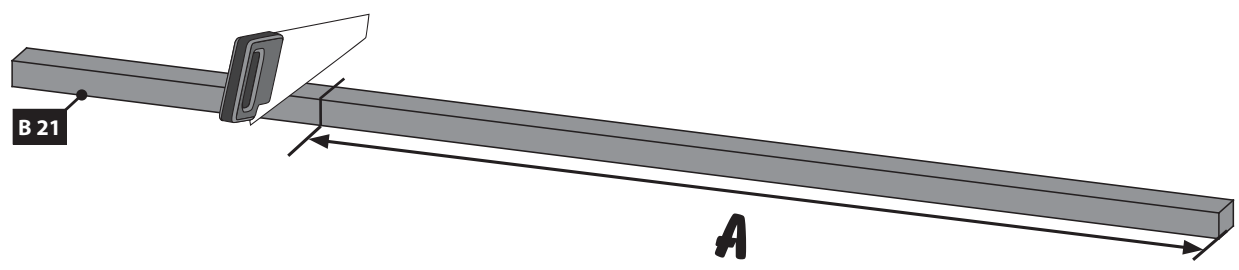

05

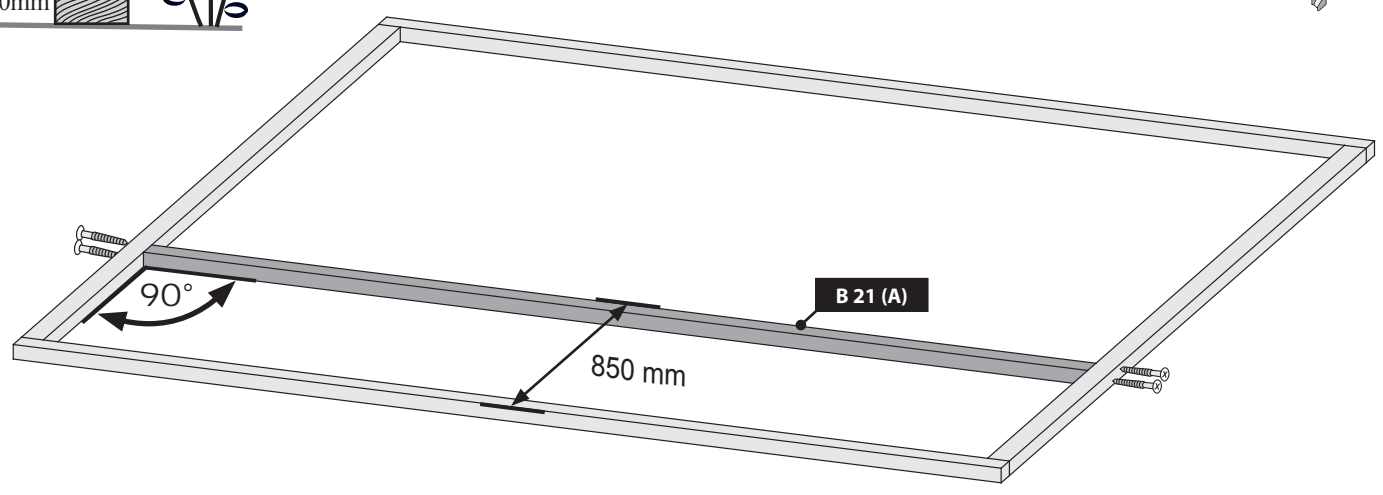
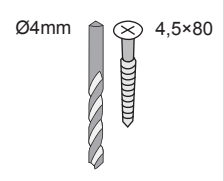
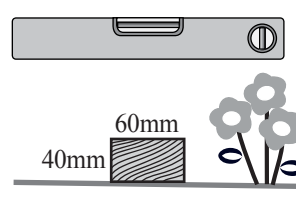

06 3x

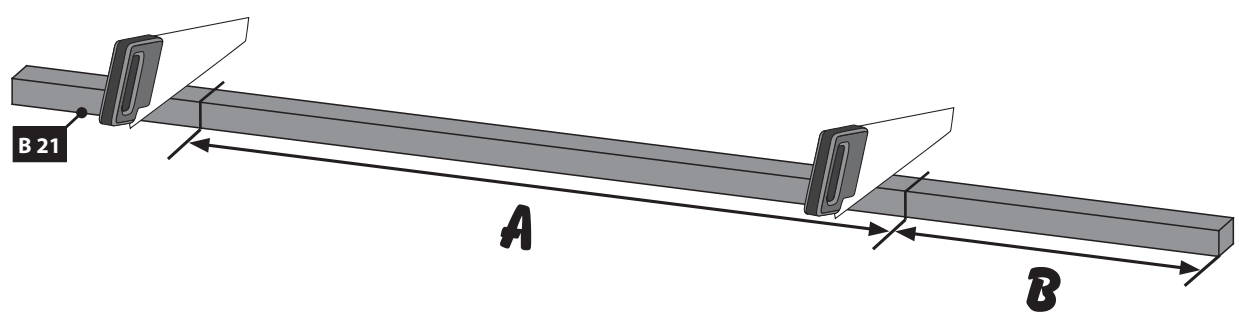



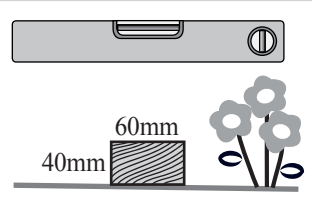

07

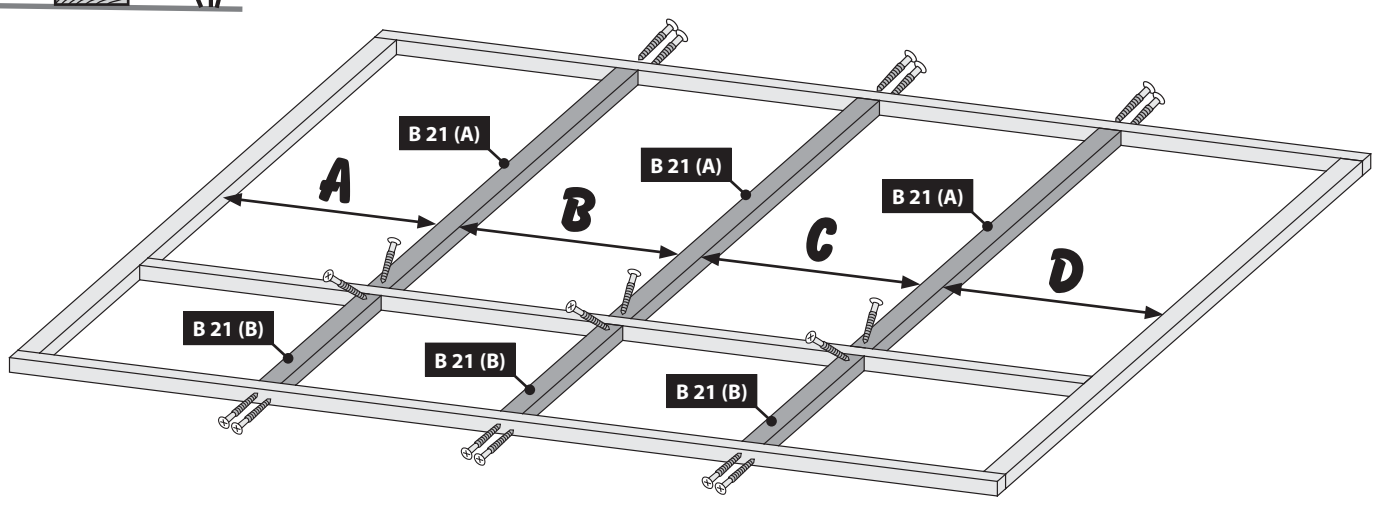
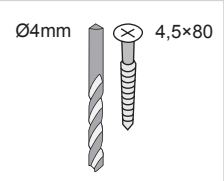

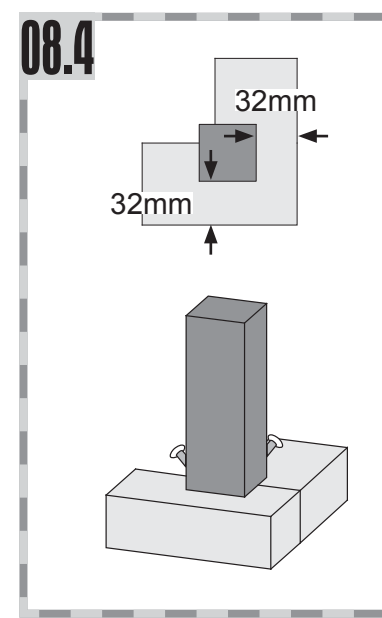
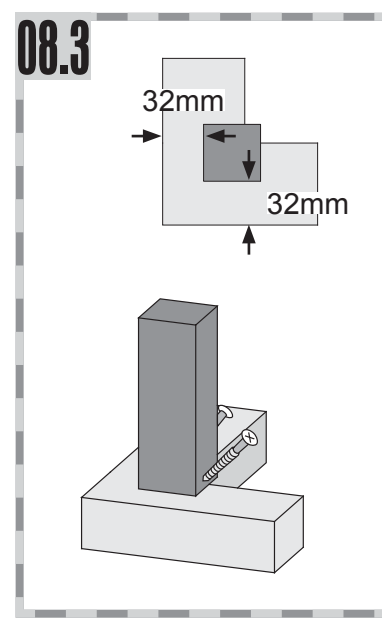
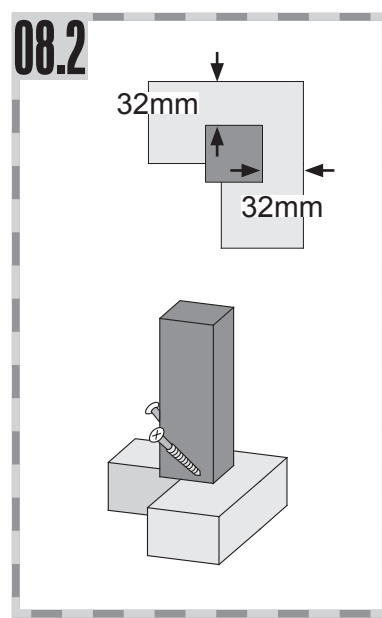
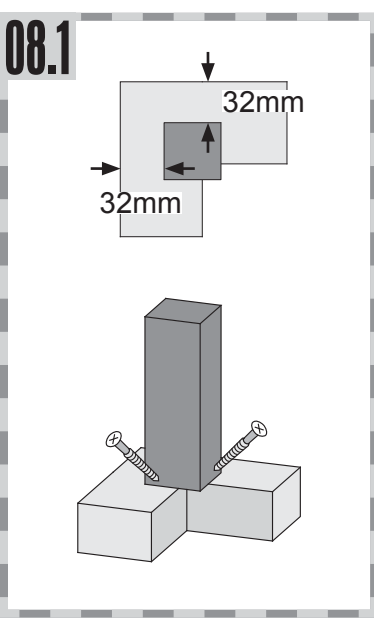
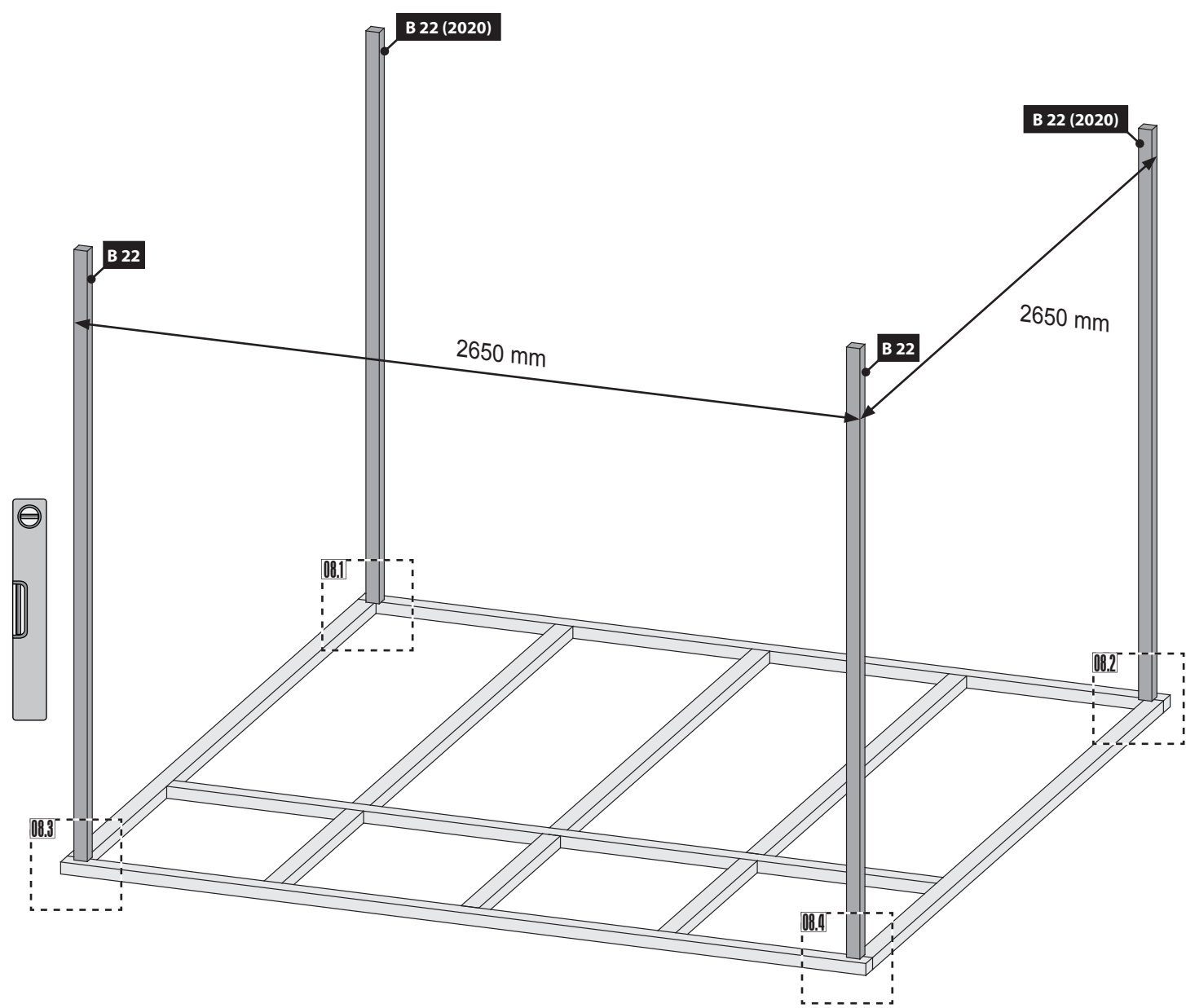
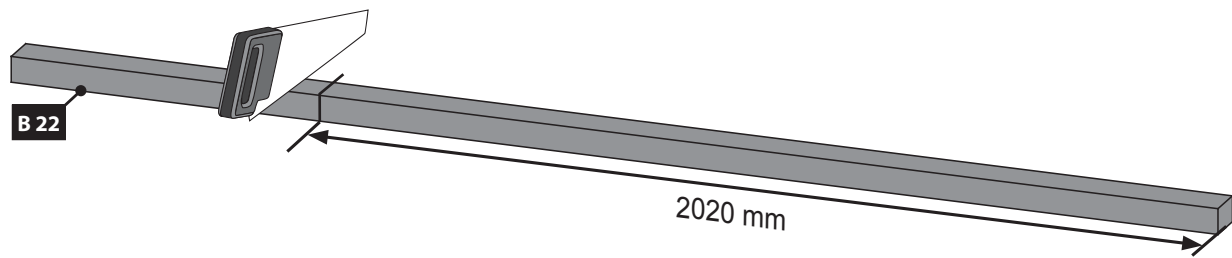
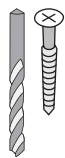

!!! A=B=C=D !!!





 Leim! Achten Sie auf die gleiche Höhe
 Glue! Look for the same height
 Colle! Faites attention à la même hauteur

 Lijm! Besteed aandacht aan de dezelfde hoogte
 Pegamento! Prestar atención a la misma altura
 Colla! Prestare attenzione alla stessa altezza

 Klíž! Dávejte pozor na stejnou výšku

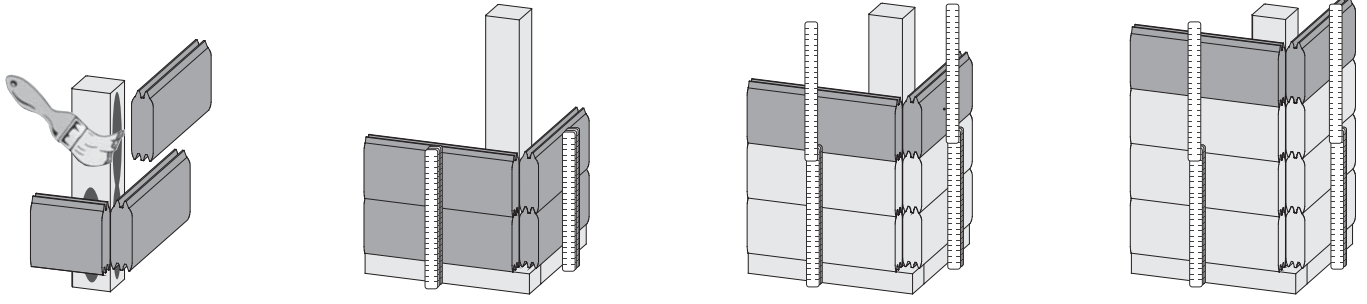

09

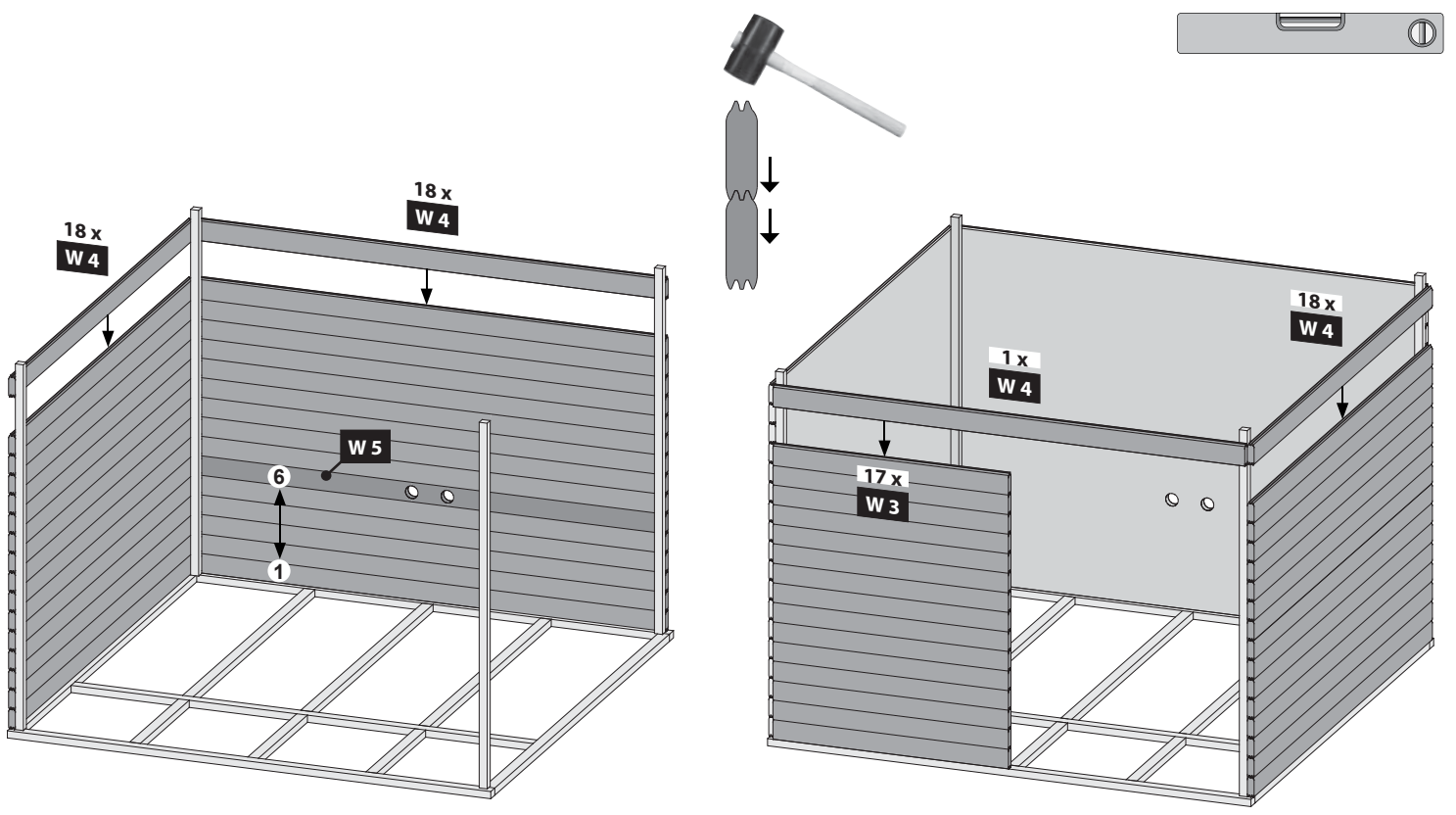

10

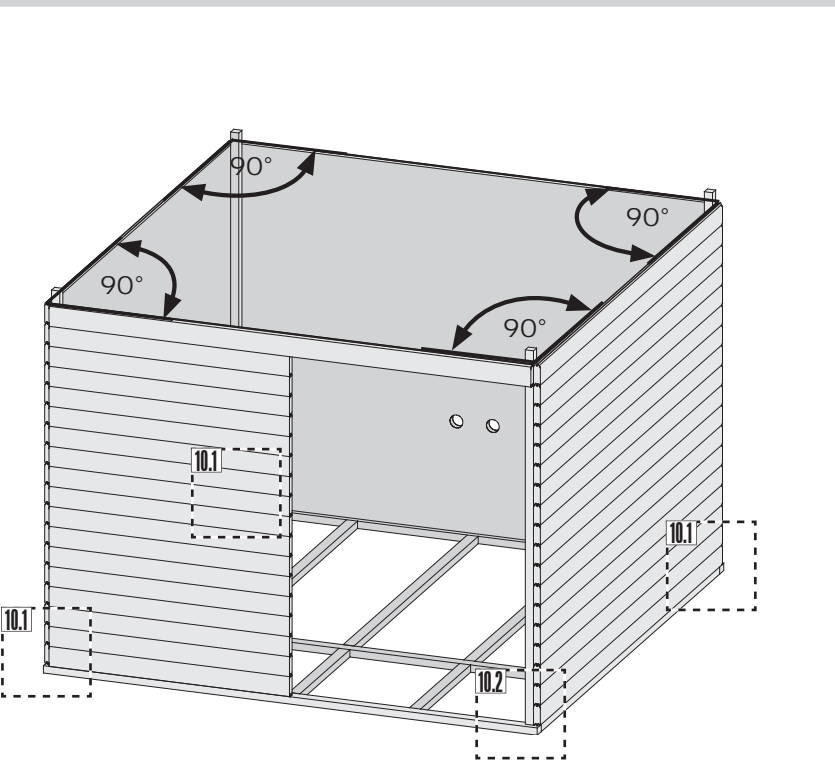

10.1

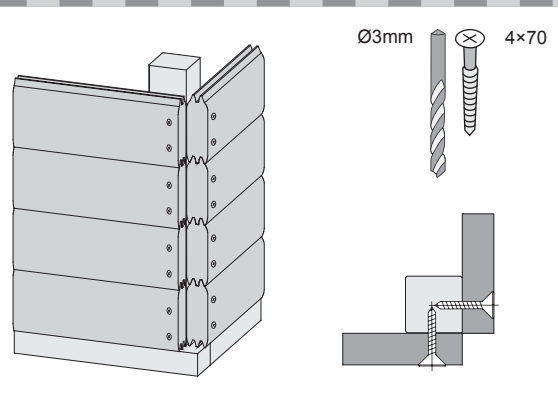

10.2

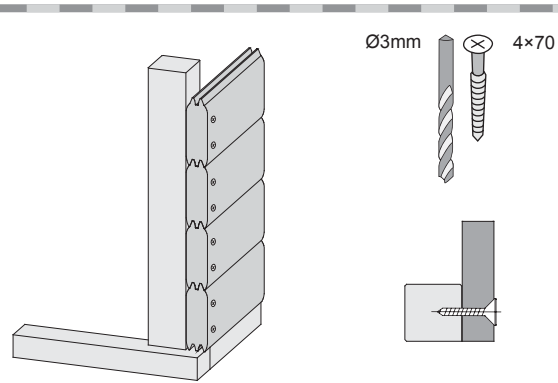

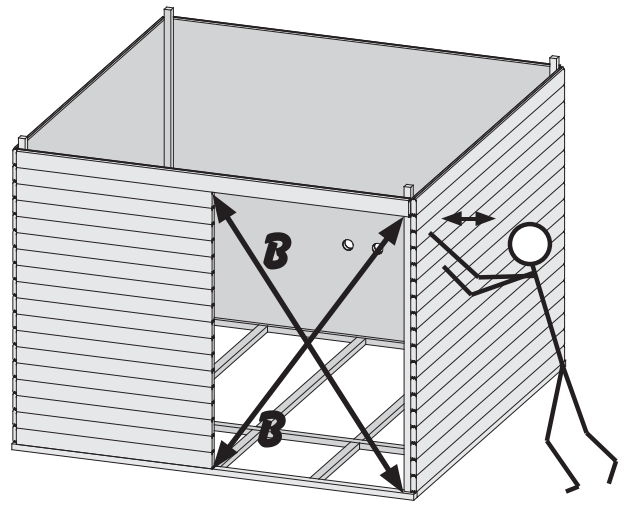
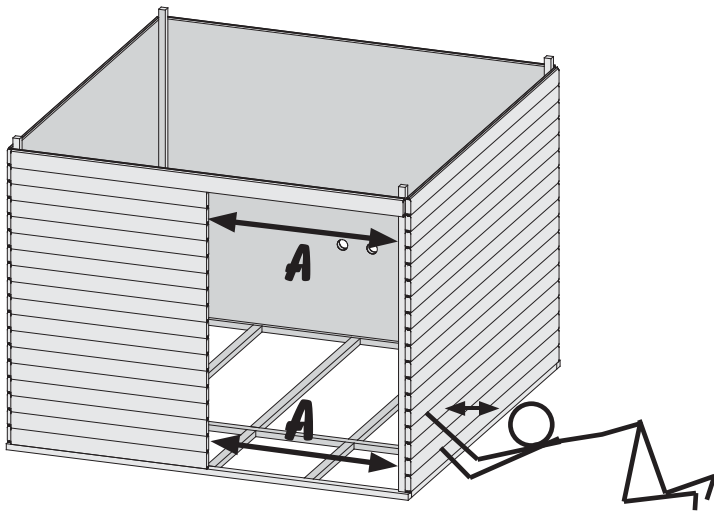

11

- * Fixiert vorübergehend
- tijdelijk vast
- Fixed temporarily
- temporairement fixe
- temporalmente fijo
- temporaneamente fisso
- dočasně pevný

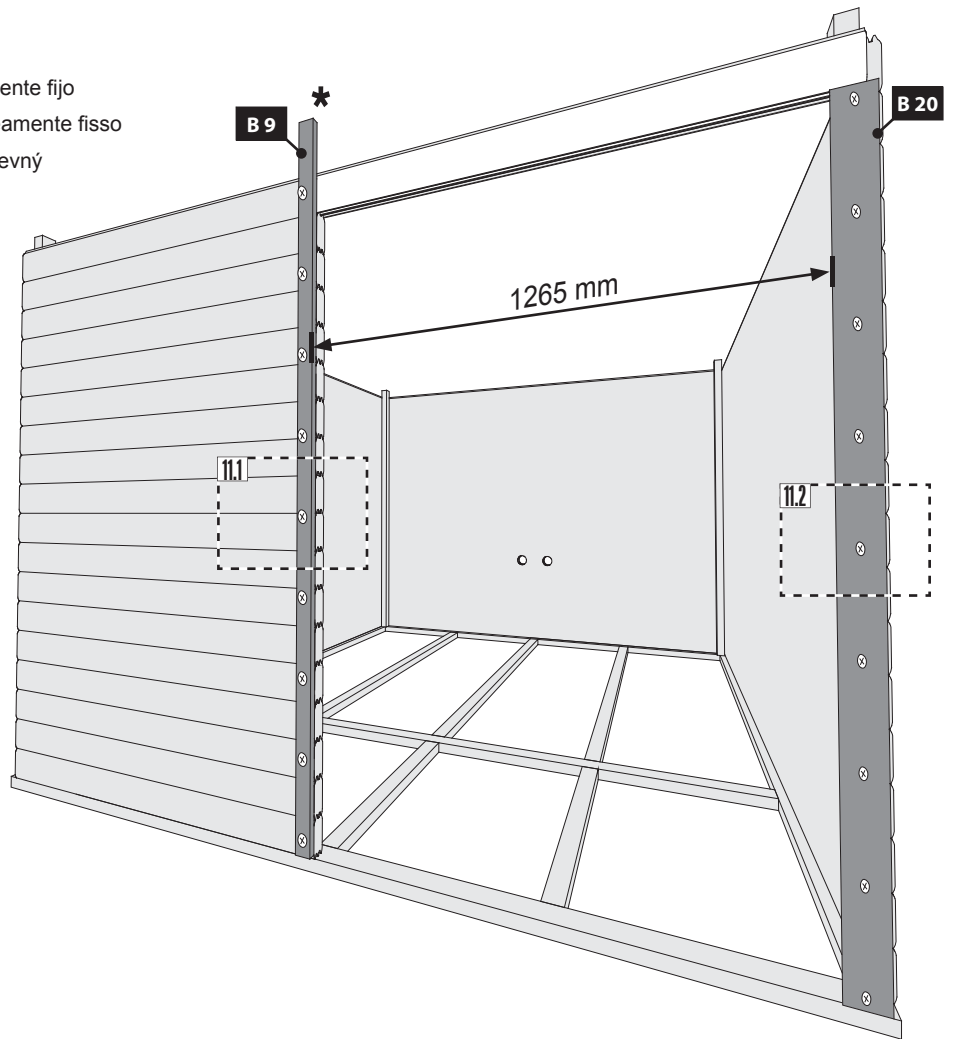
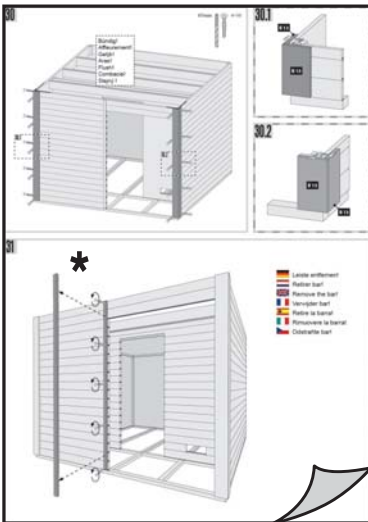

11.1

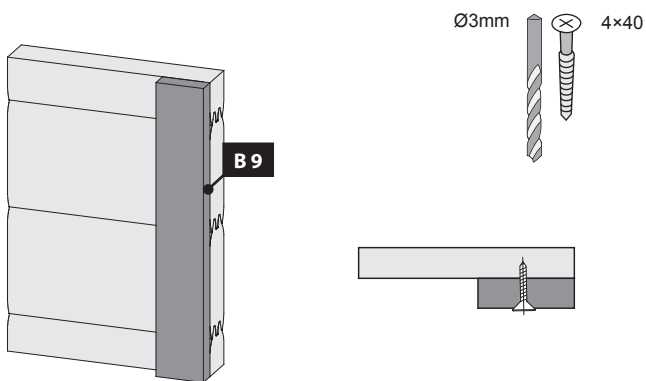

11.2

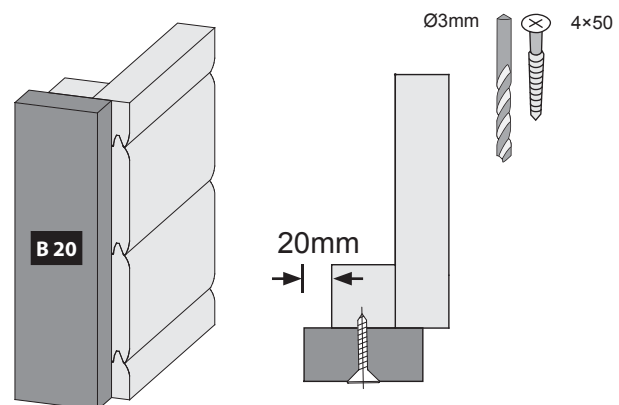



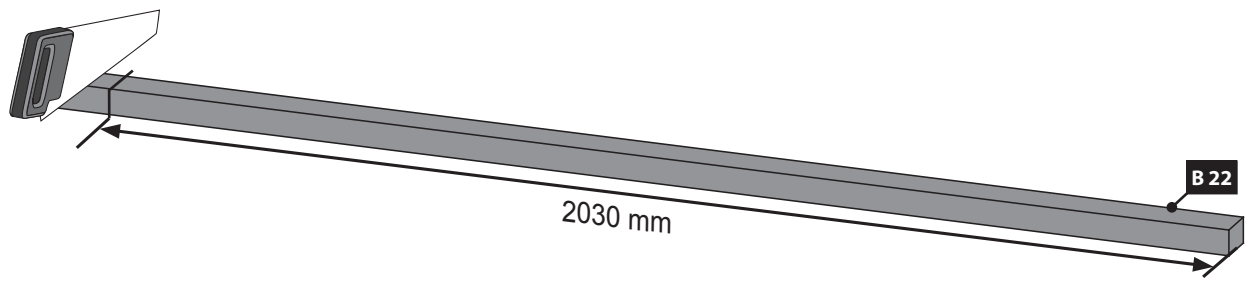

12 2x

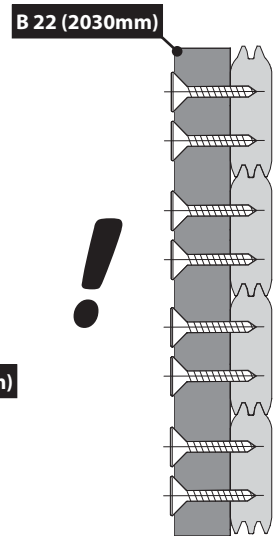
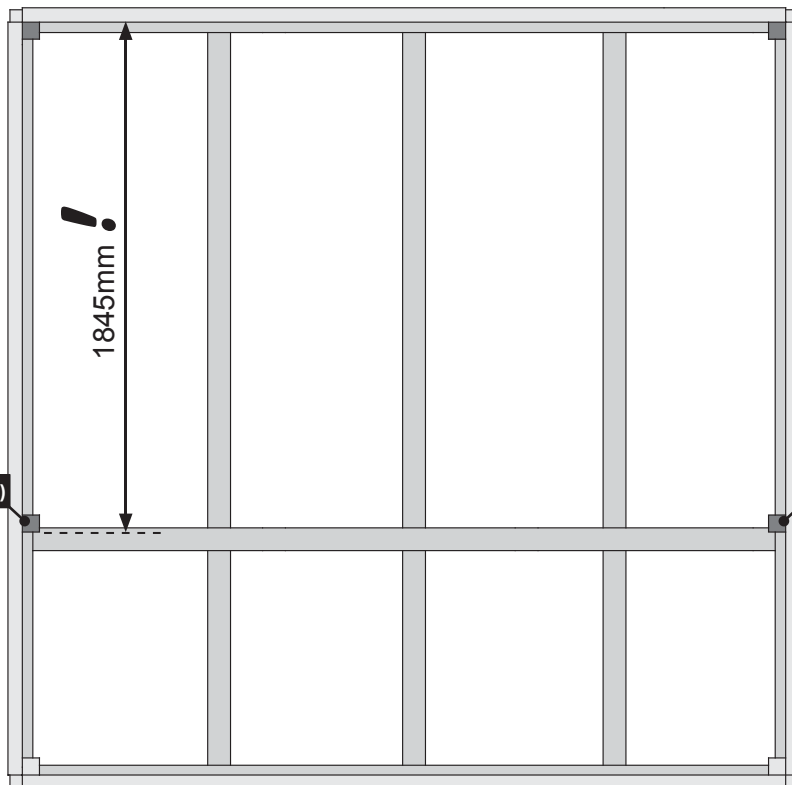
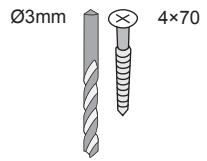

13



 Draufsicht
 bovenaanzicht
 Top view

 vue de dessus
 vista desde arriba
 vista dall'alto

 púdorys

-  Eingang
-  invoer
-  entrance
-  apport
-  entrada
-  entrata
-  vstup

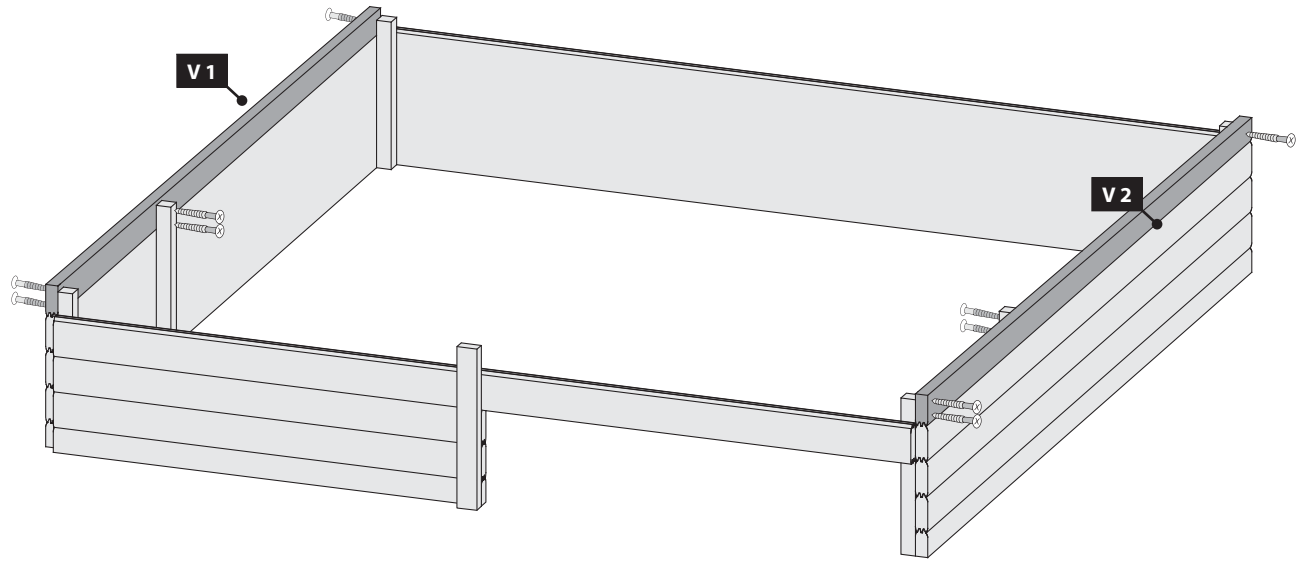
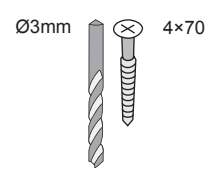
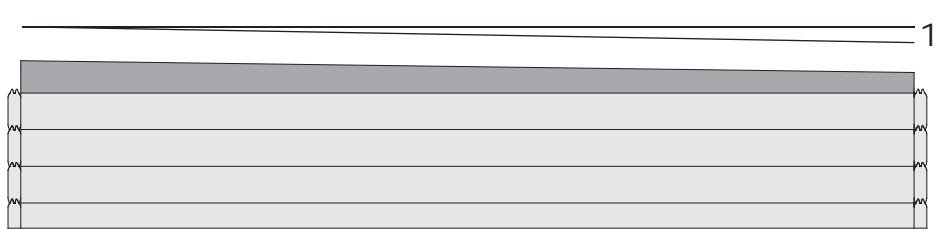

- Bündig!
- Affleurement!
- Gelijk!
- Aras!
- Flush!
- Combacia!
- Stejný !

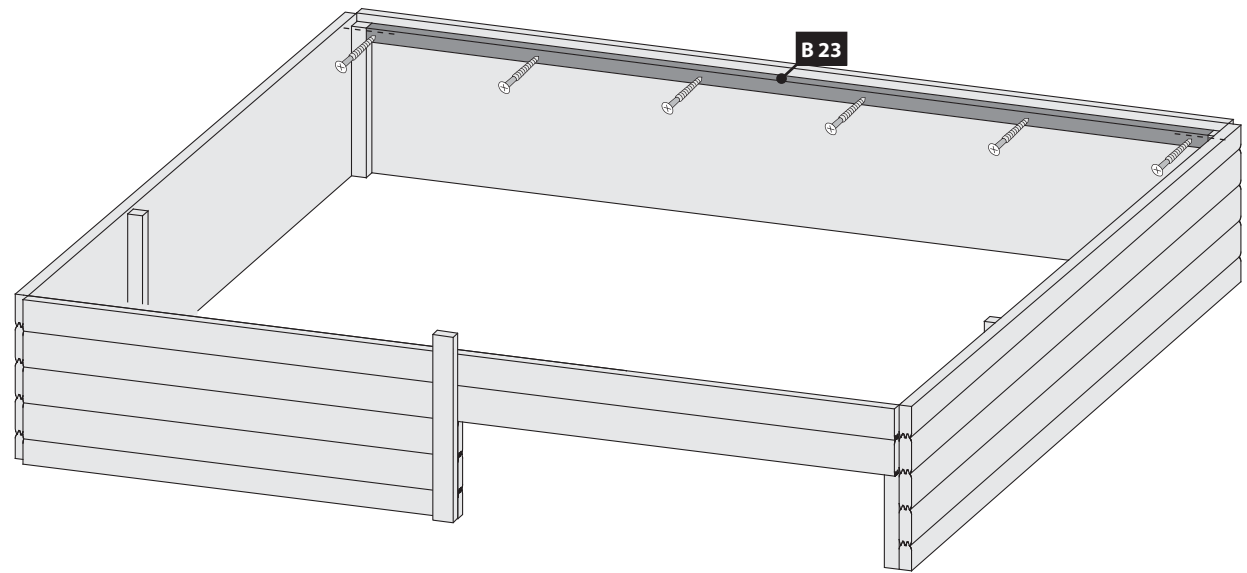
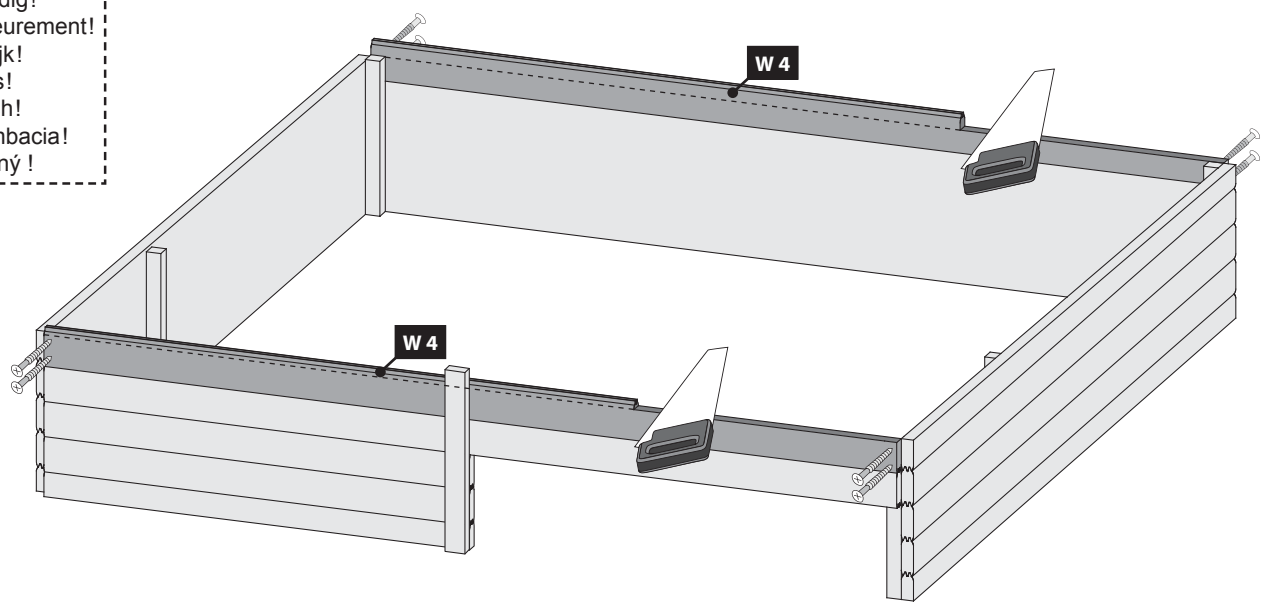
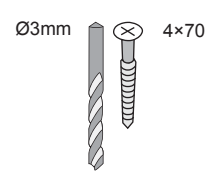

16 2x

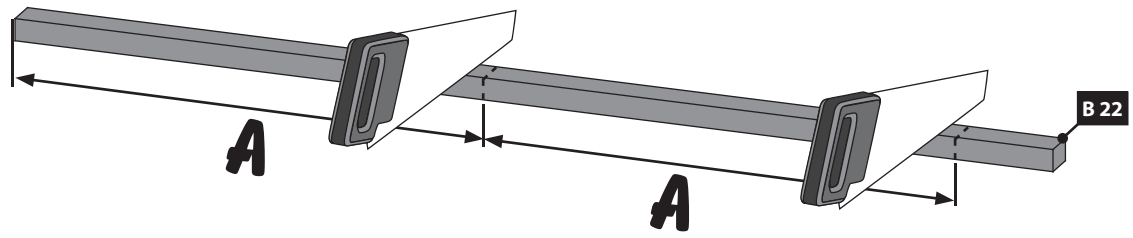

17 1x

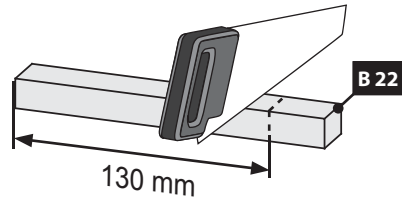

18

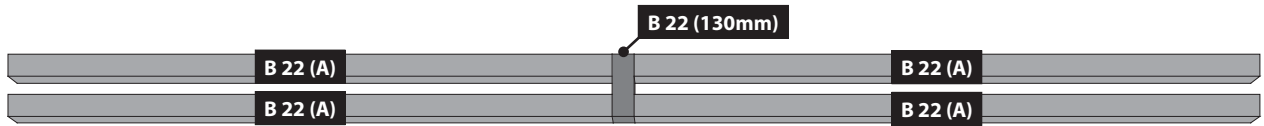
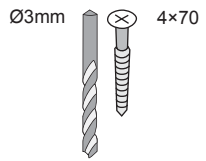

Bündig!
 Affleurement!
 Gelijk!
 Aras!
 Flush!
 Combacia!
 Stejný !

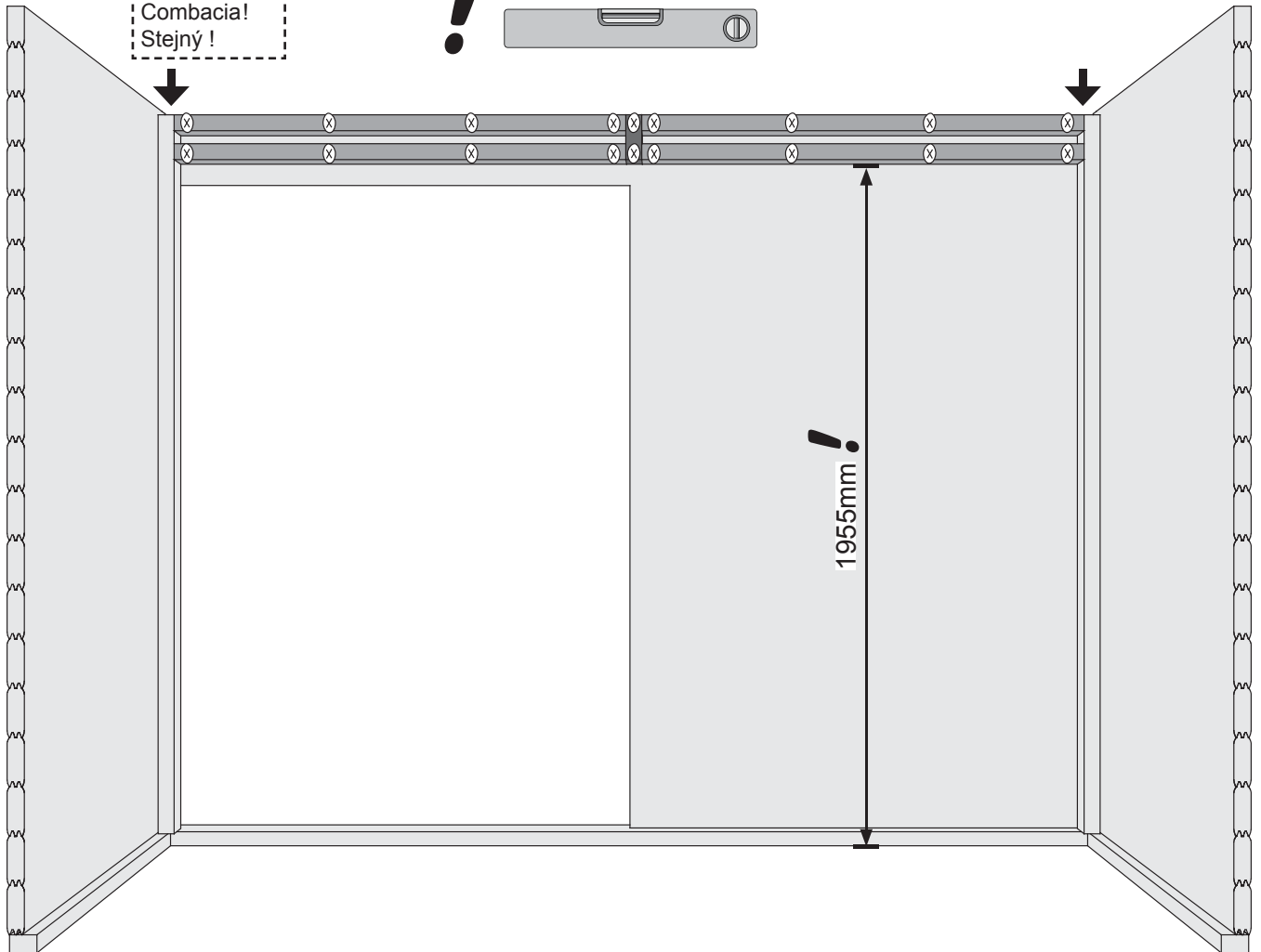
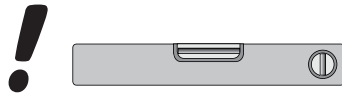

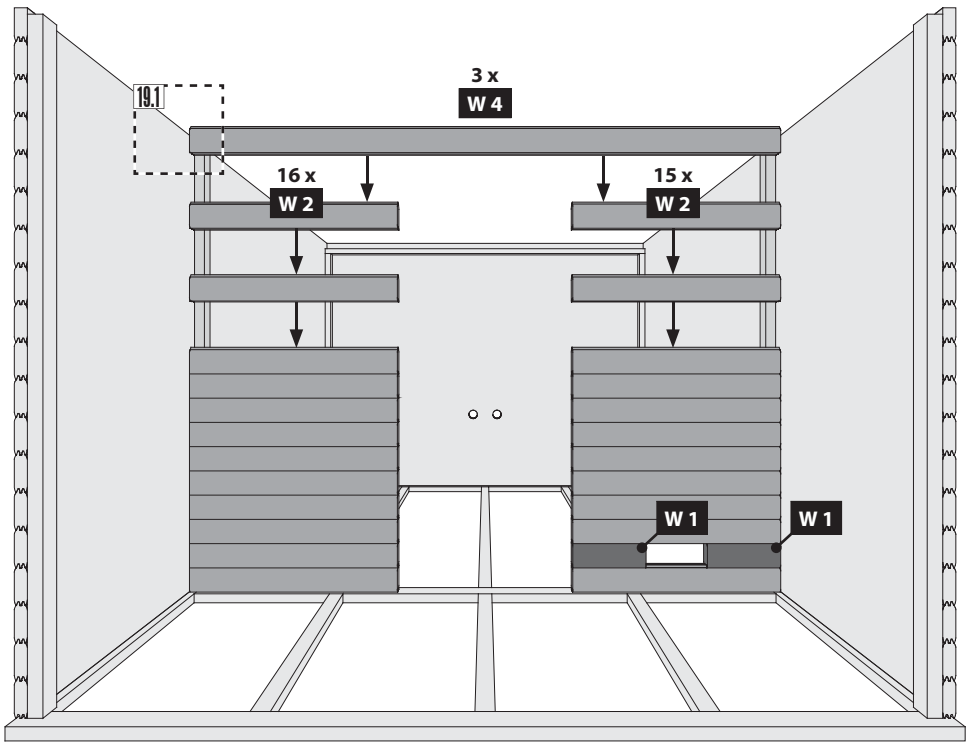

19.1

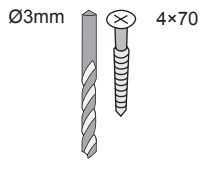
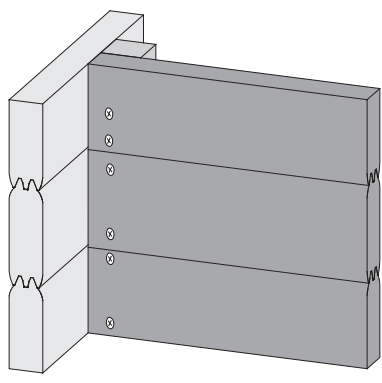

20.1

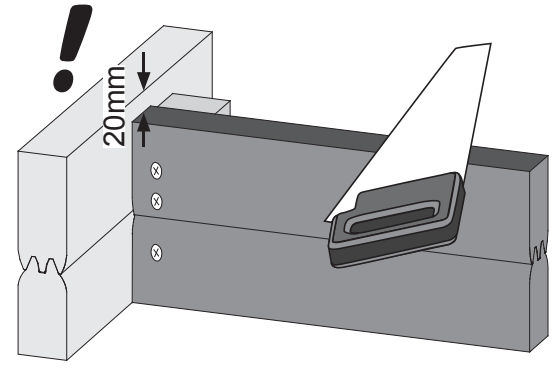

20

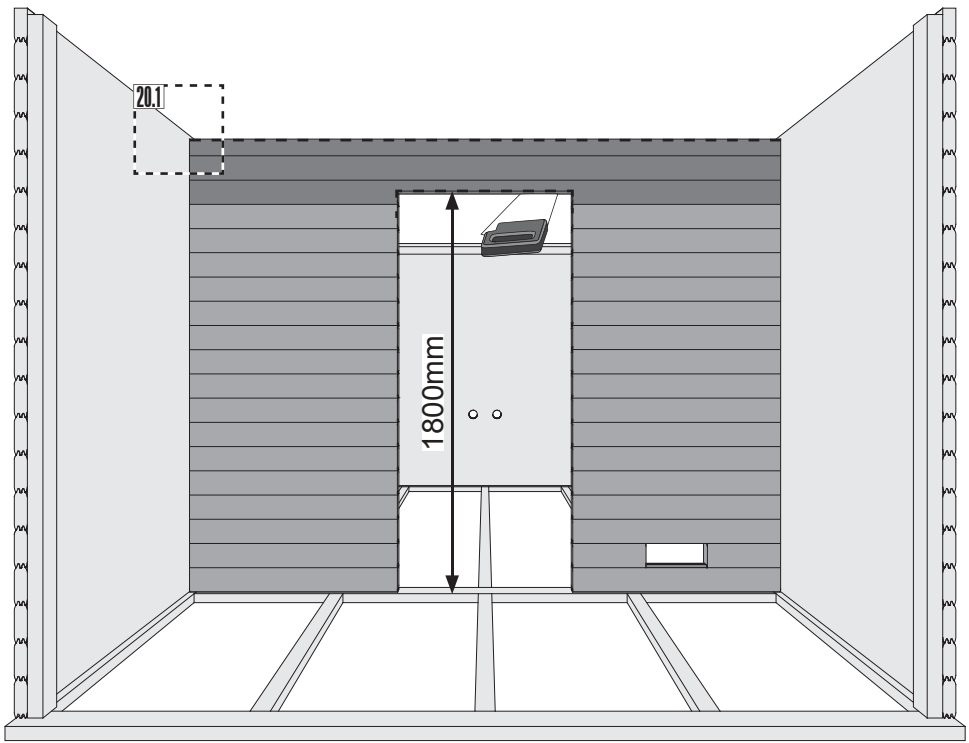

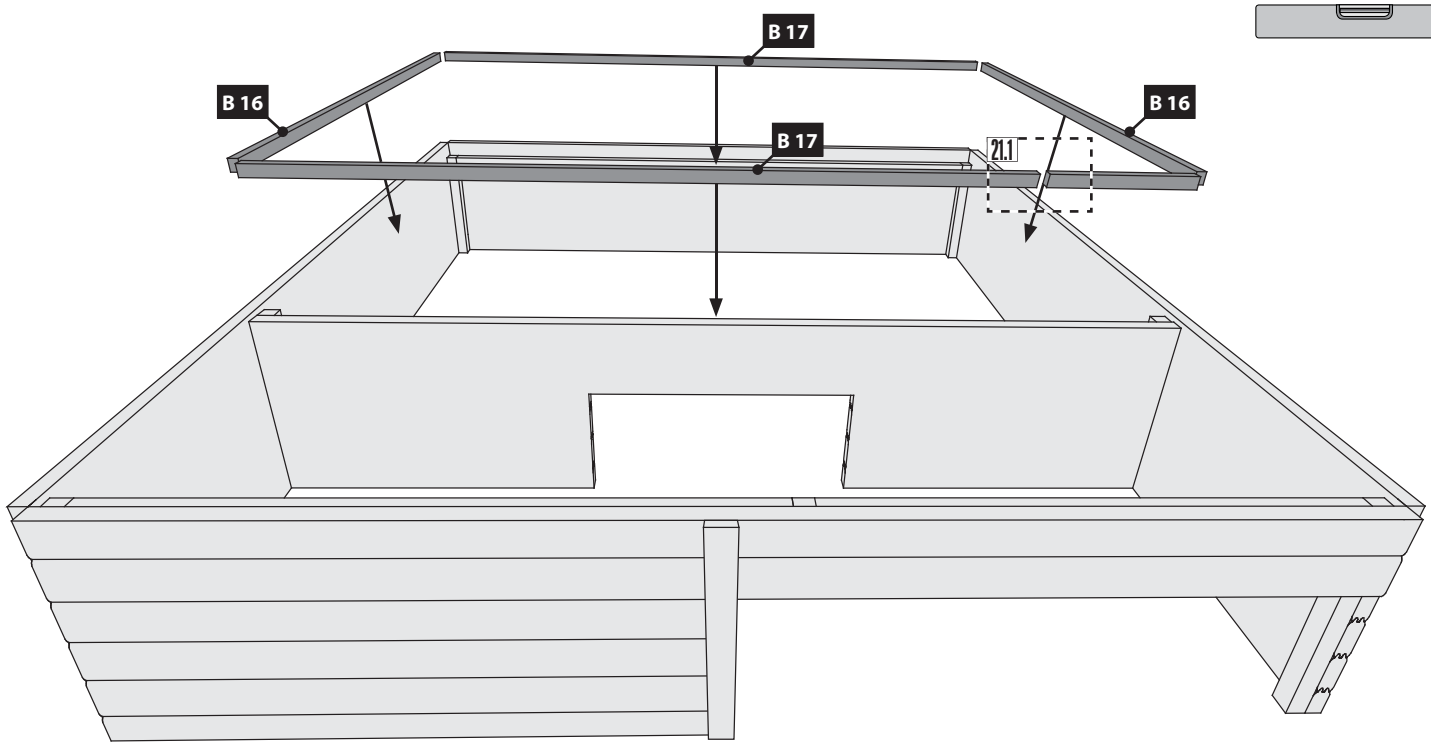

21.1

-  Kabeldurchführung
-  kabelingang
-  cable inlet
-  entrée de câble
-  entrada del cable
-  ingresso cavi
-  kabelová průchodka

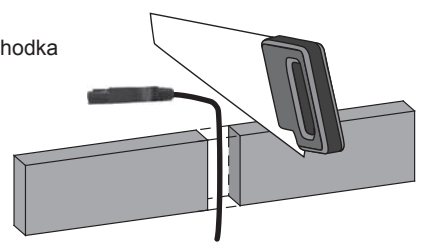

22.1

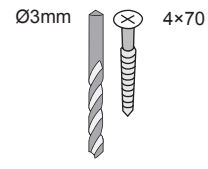
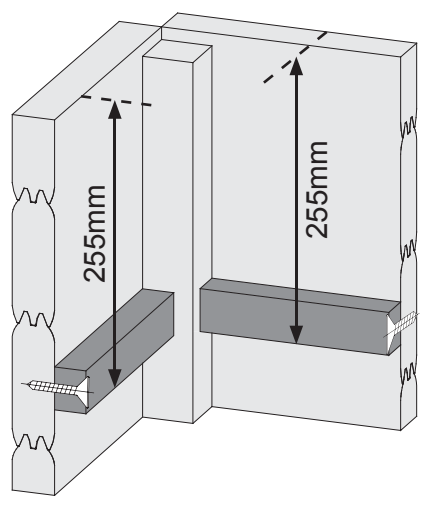

22

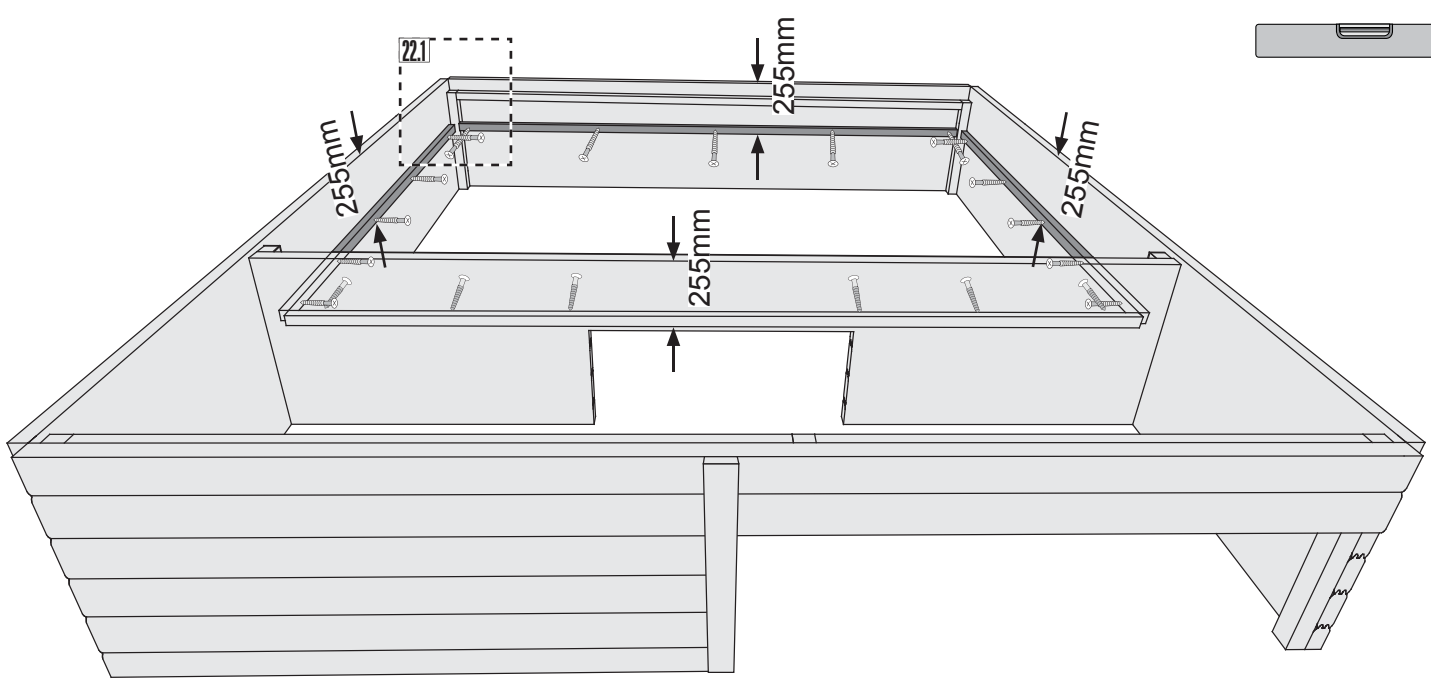

23 2x

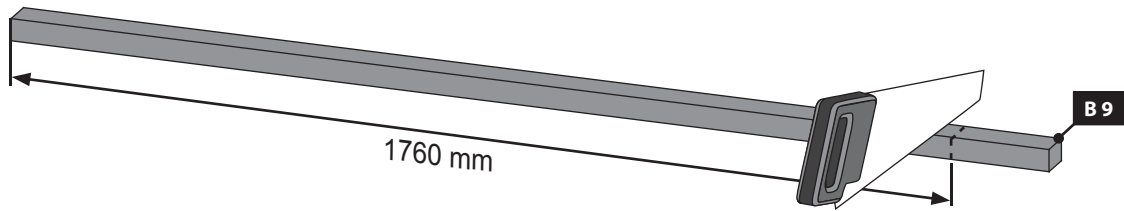

24

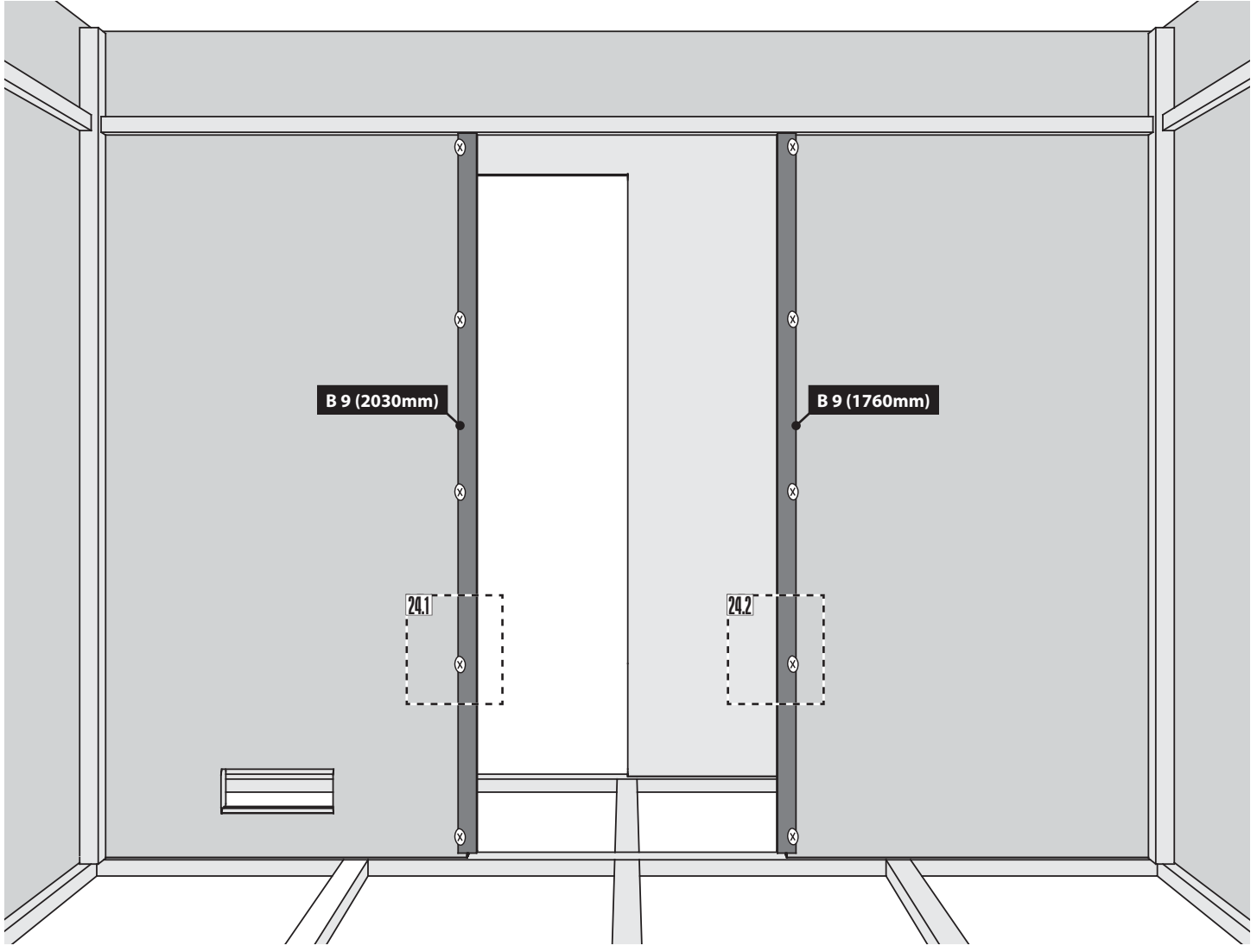

24.1

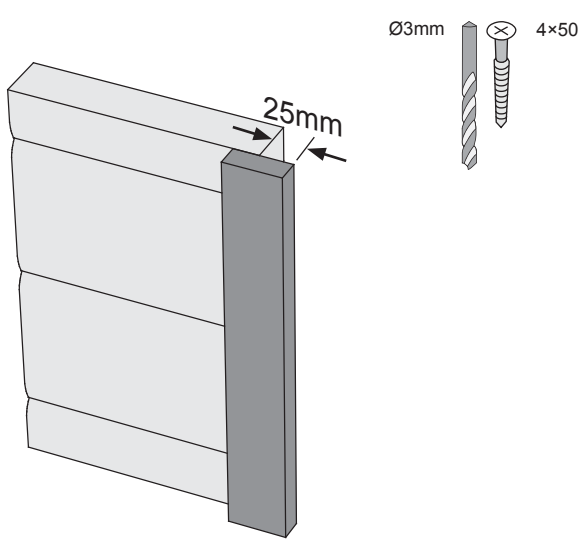

24.2

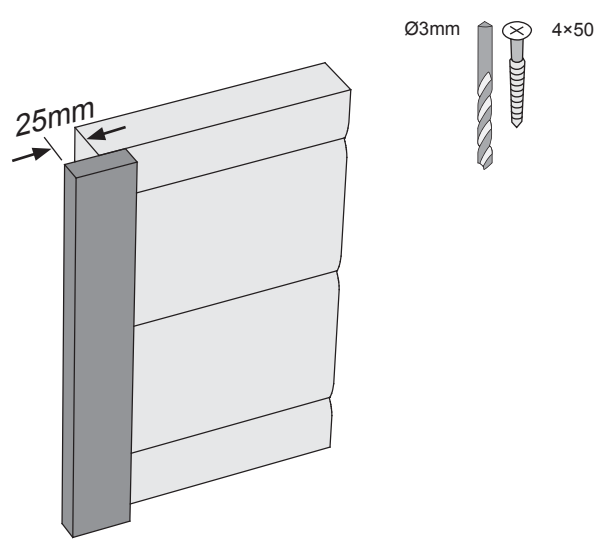

Bündig!
 Affleurement!
 Gelijk!
 Aras!
 Flush!
 Combacia!
 Stejný!

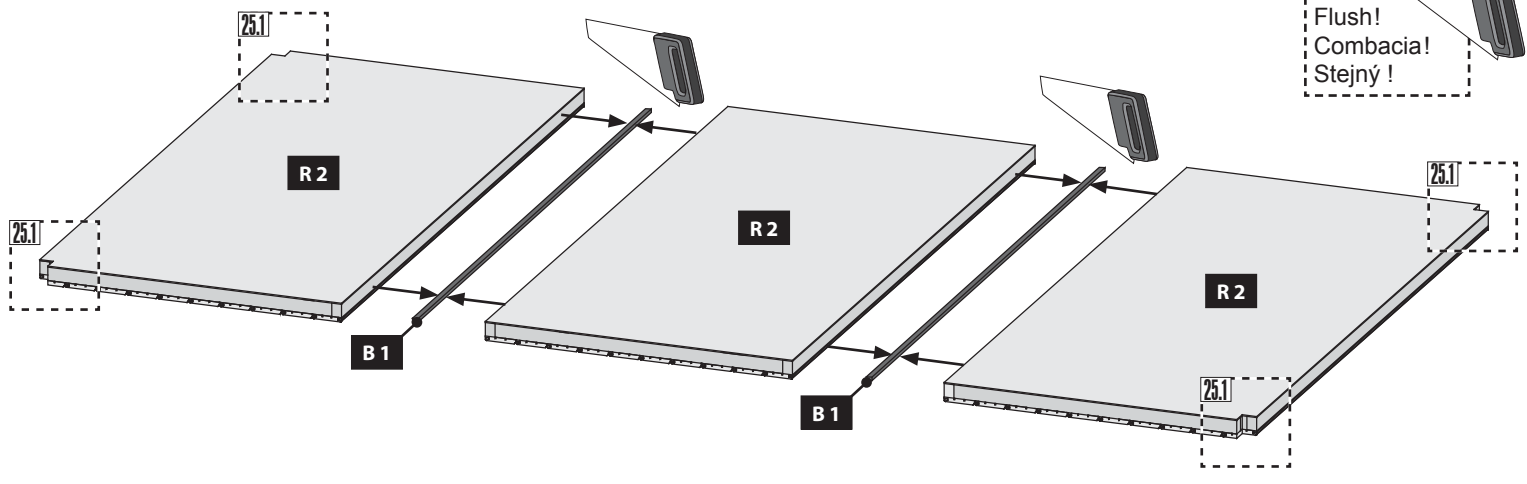

25.1

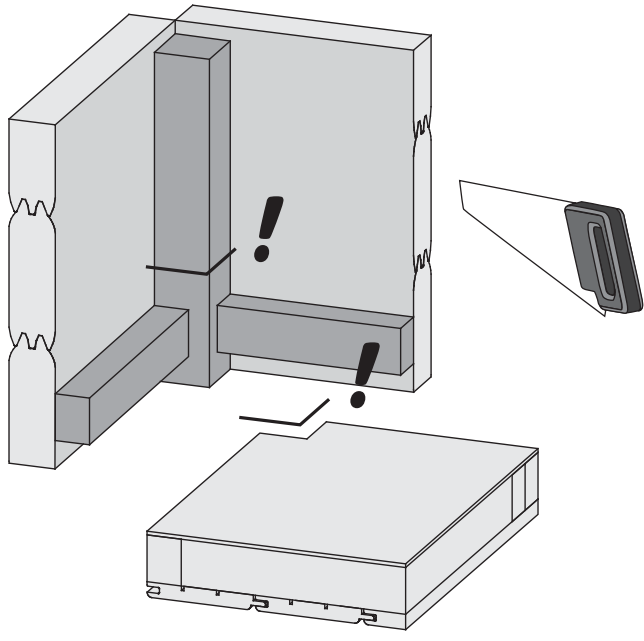

26.1

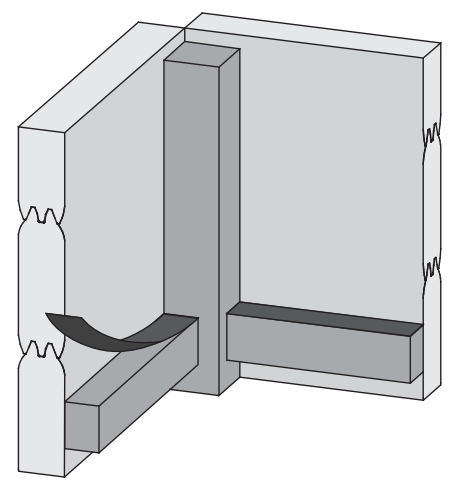

26

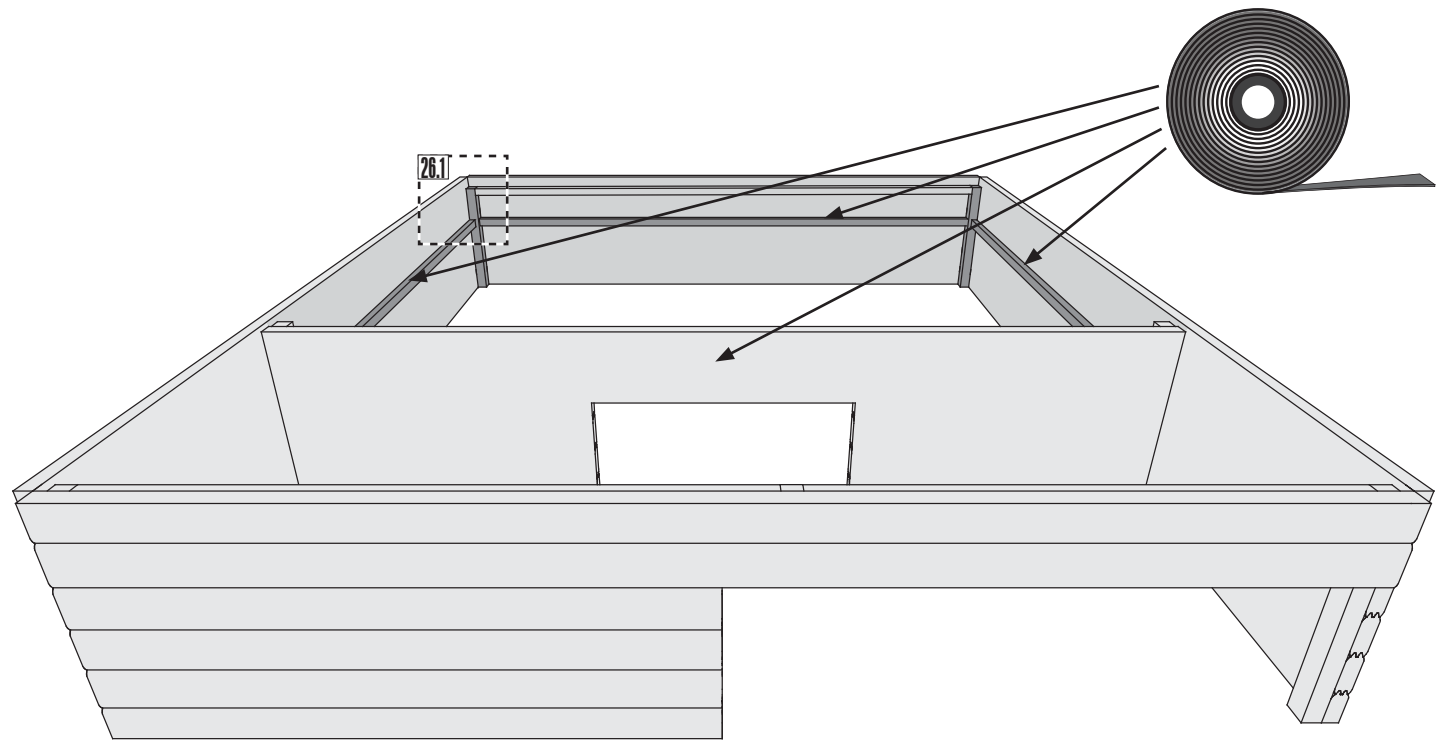

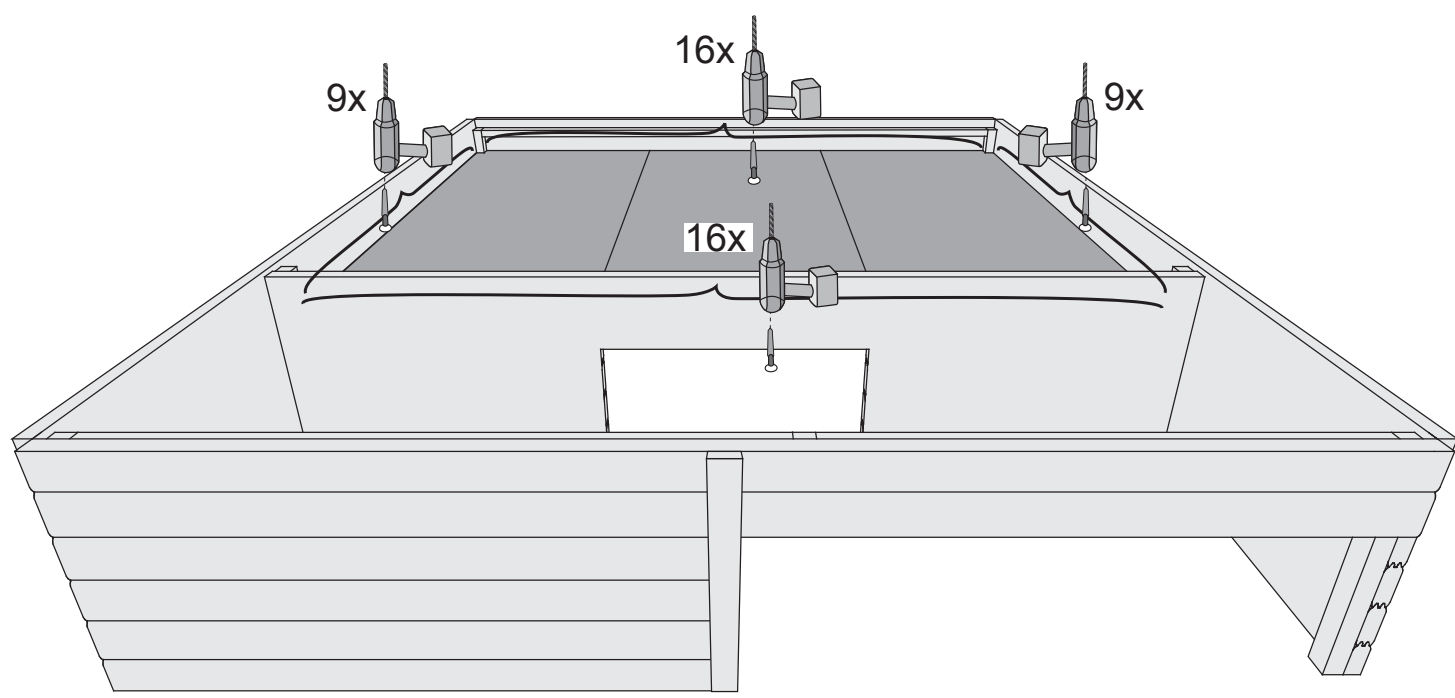
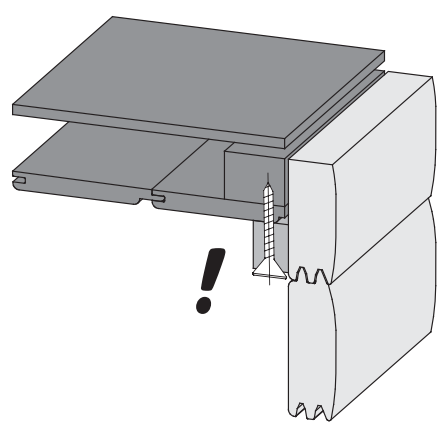
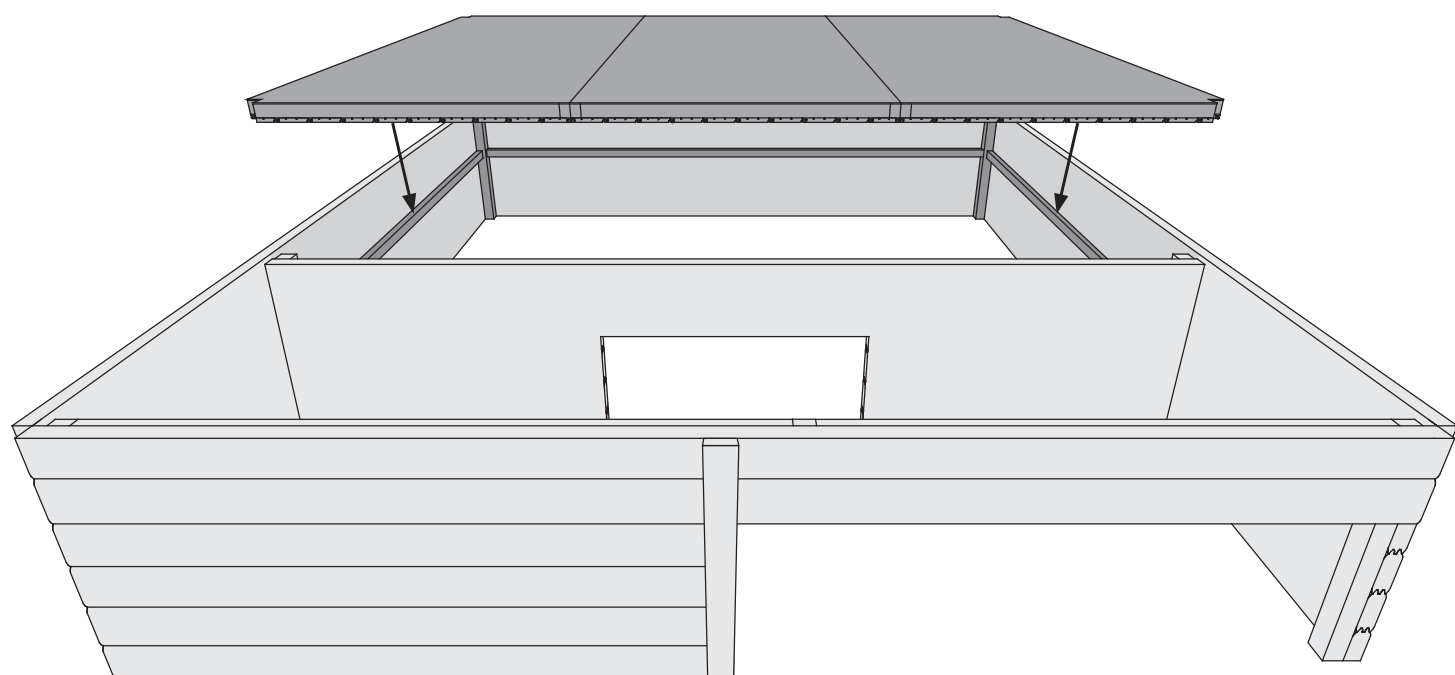
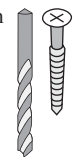

Bündig!
Affleurement!
Gelijk!
Aras!
Flush!
Combacia!
Stejný!

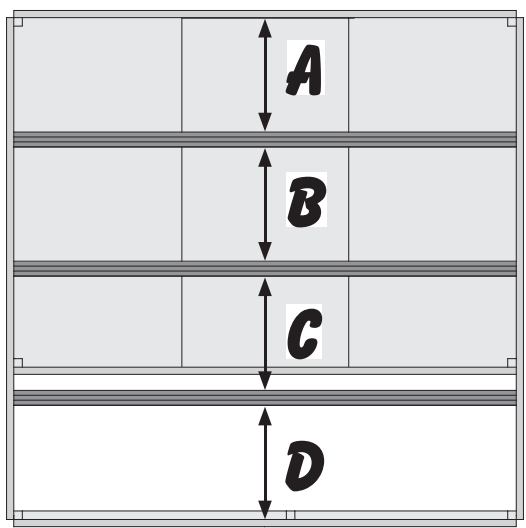
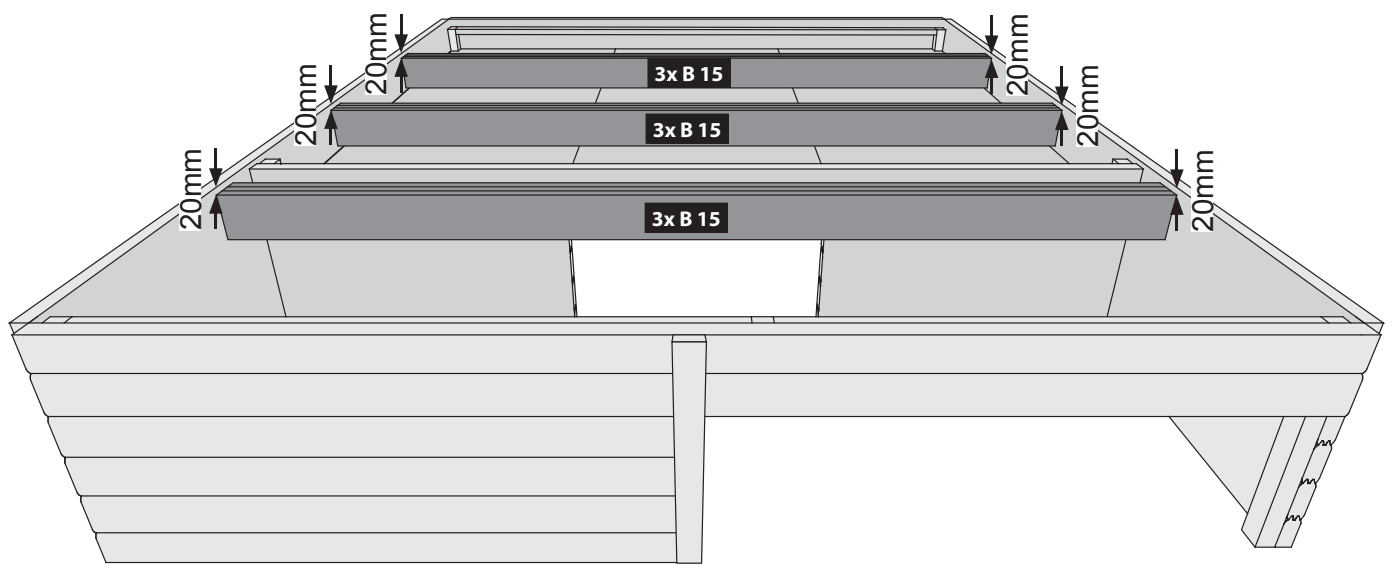
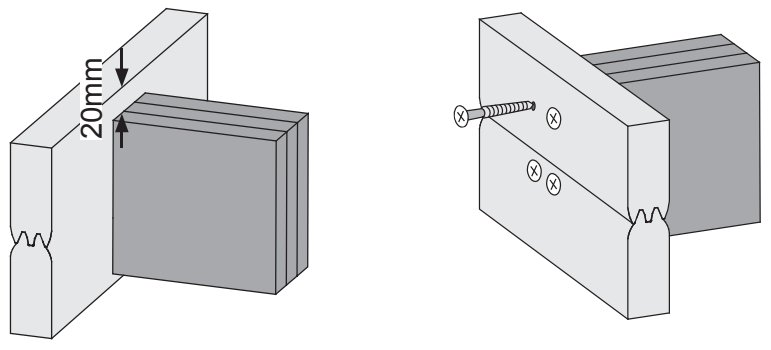
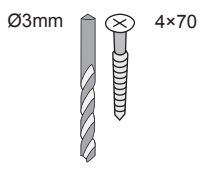
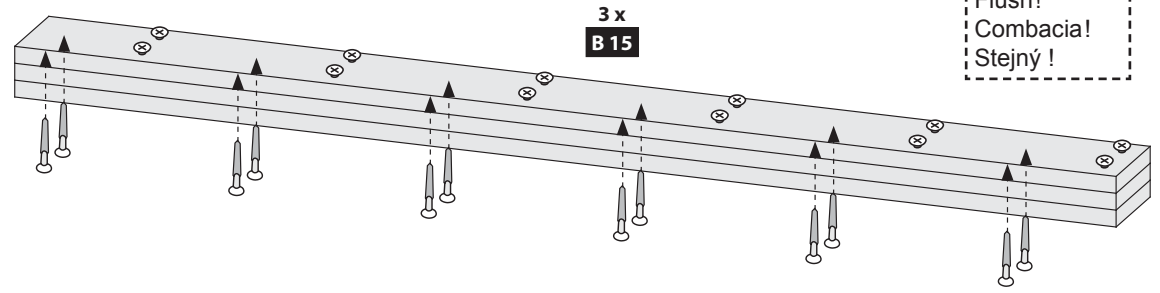
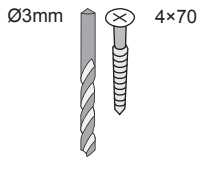

!!! A=B=C=D !!!

-  Draufsicht
-  bovenaanzicht
-  Top view
-  vue de dessus
-  vista desde arriba
-  vista dall'alto
-  púdorys

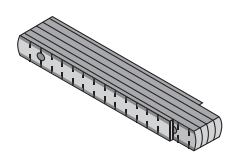

30

Ø3mm 4x50

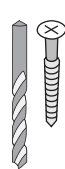

Bündig!
Affleurement!
Gelijk!
Aras!
Flush!
Combacia!
Stejný!

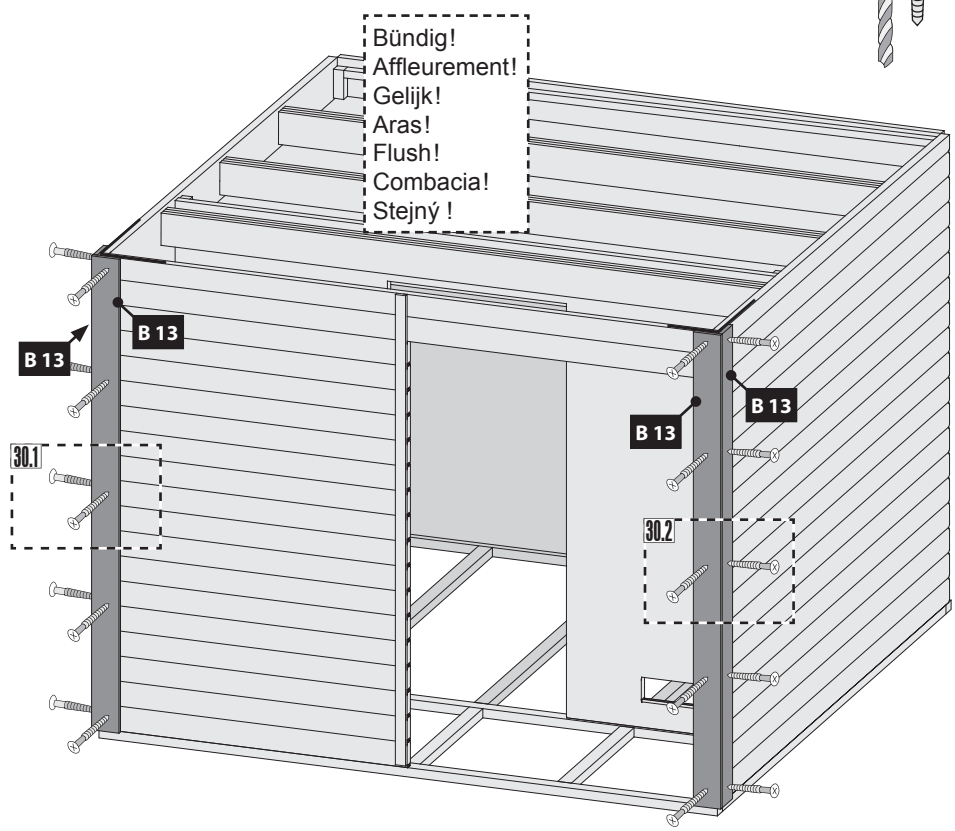

30.1

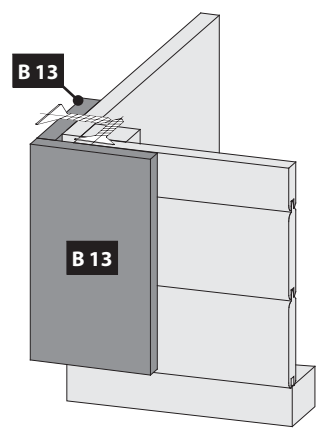

30.2

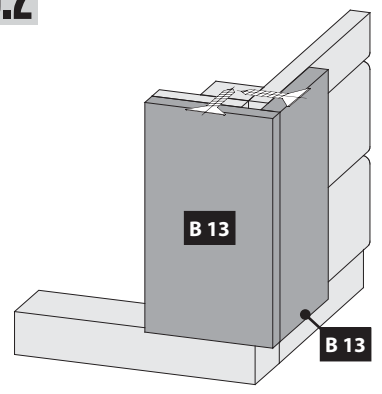

31

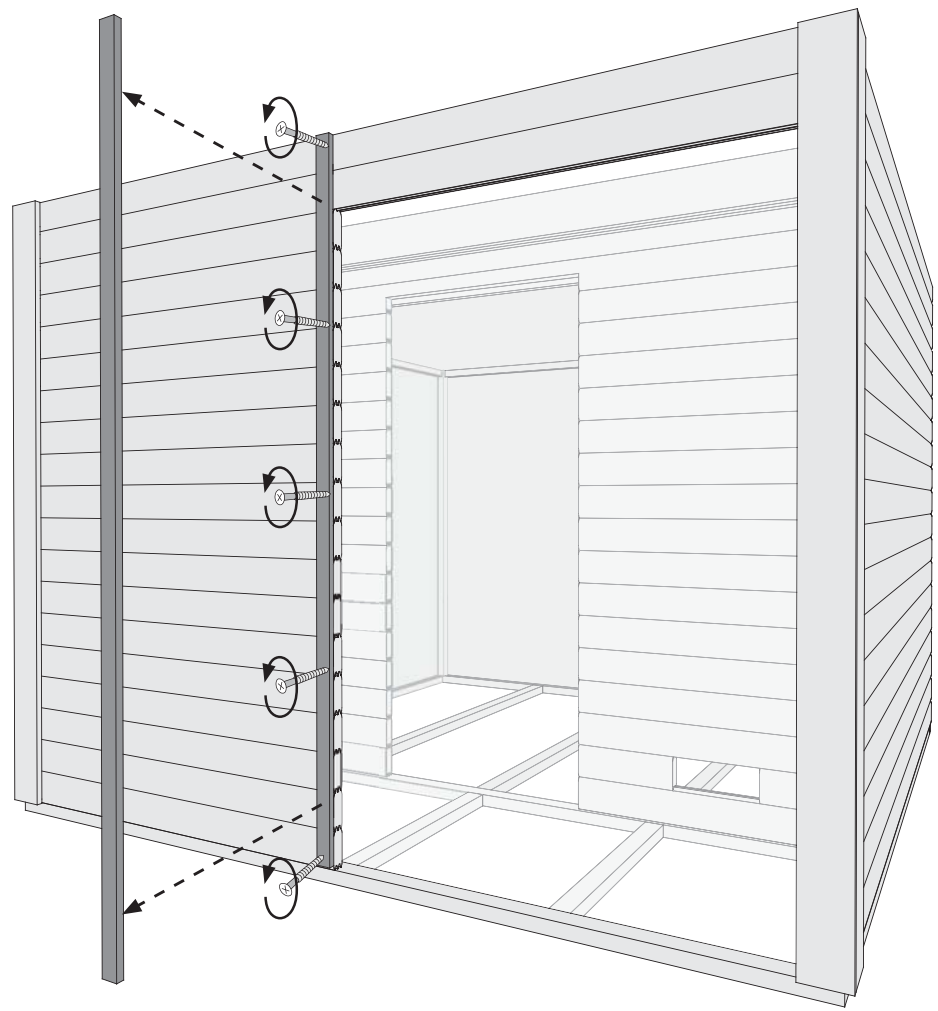

-  Leiste entfernen!
-  Retirer bar!
-  Remove the bar!
-  Verwijder bar!
-  Retire la barra!
-  Rimuovere la barra!
-  Odstraňte bar!

Bündig!
Affleurement!
Gelijk!
Aras!
Flush!
Combacia!
Stejný!



1x

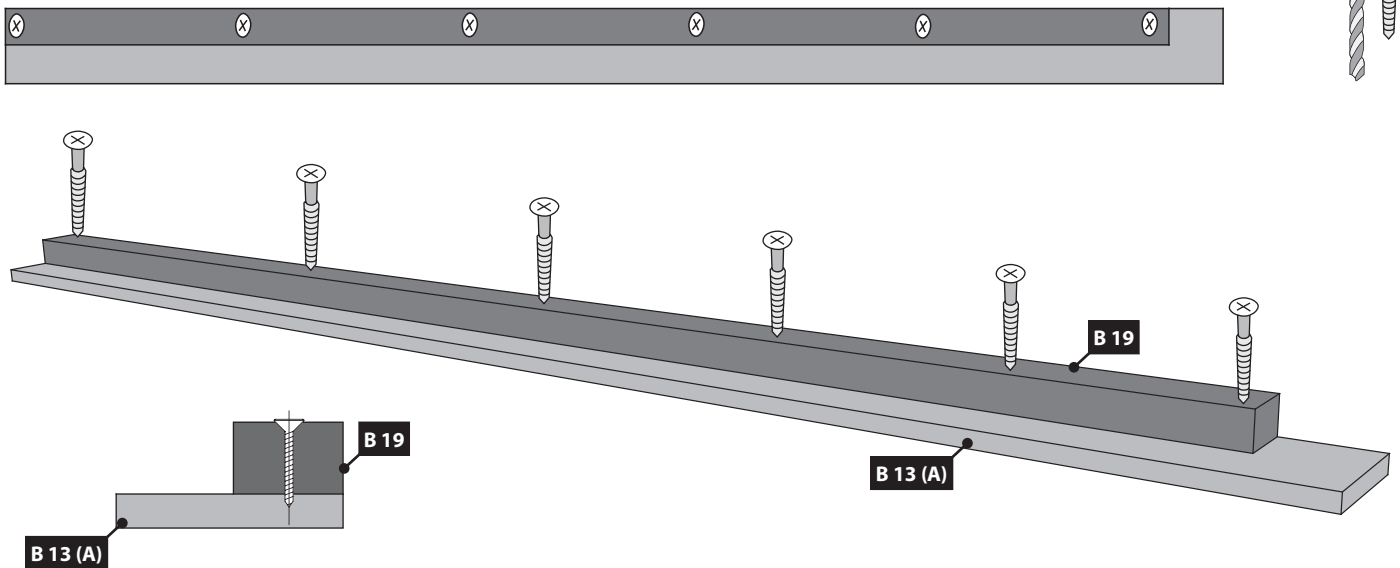
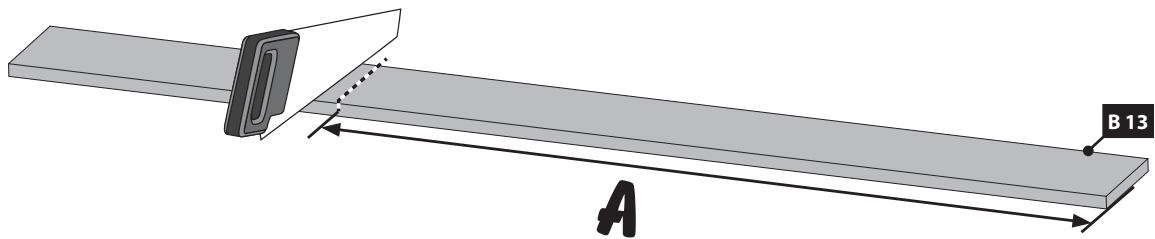

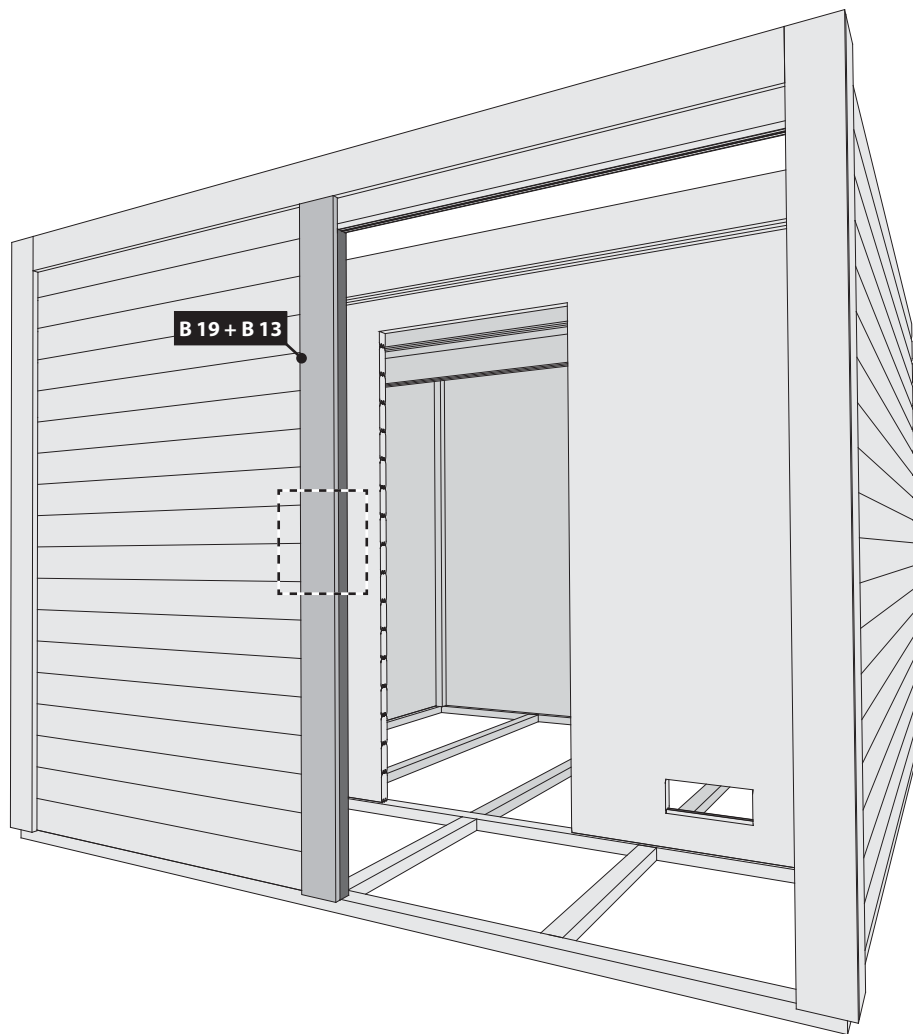

Ø3mm 4x50

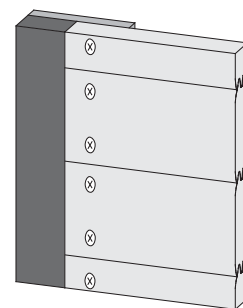
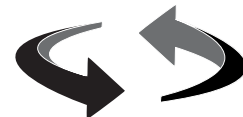
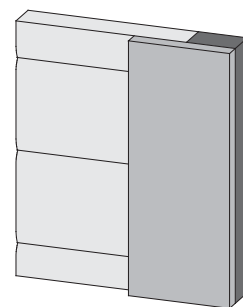
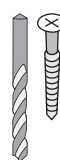

34x

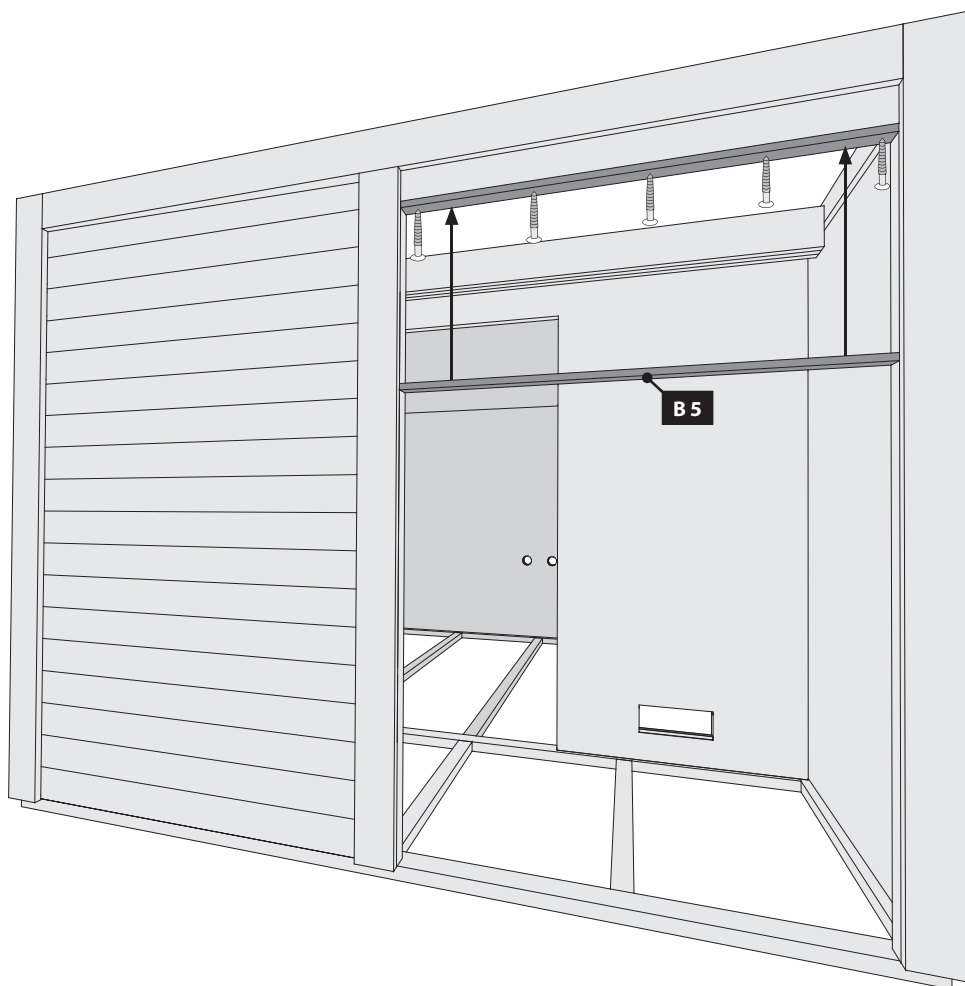

Ø3mm 4x40

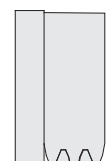
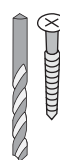

Bündig!
 Affleurement!
 Gelijk!
 Aras!
 Flush!
 Combacia!
 Stejný !

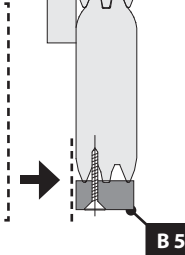

B 5

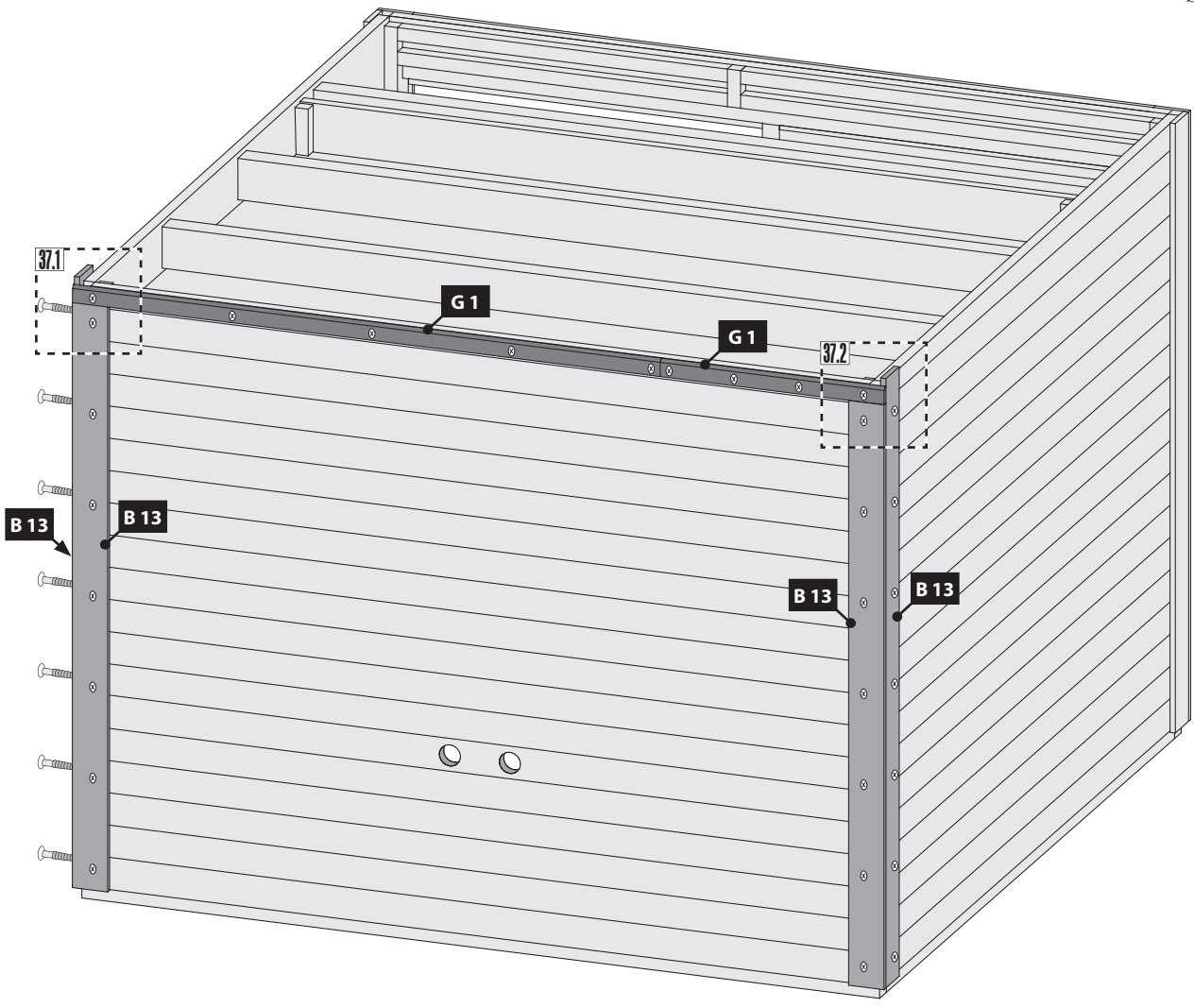
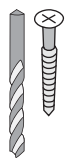

37.1

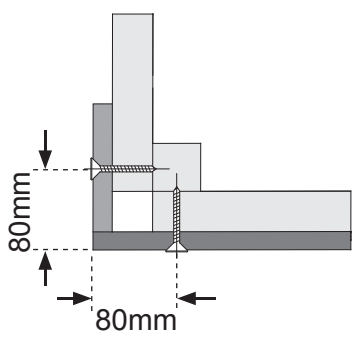

Bündig!
Affleurement!
Gelijk!
Aras!
Flush!
Combacia!
Stejný !

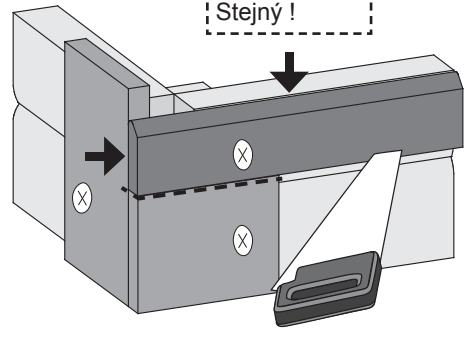

37.2

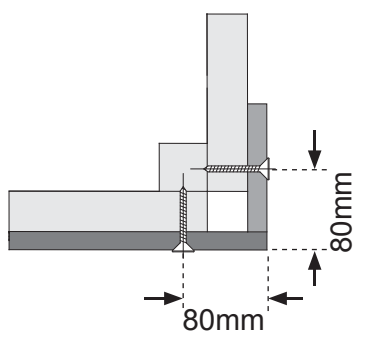

Bündig!
Affleurement!
Gelijk!
Aras!
Flush!
Combacia!
Stejný !

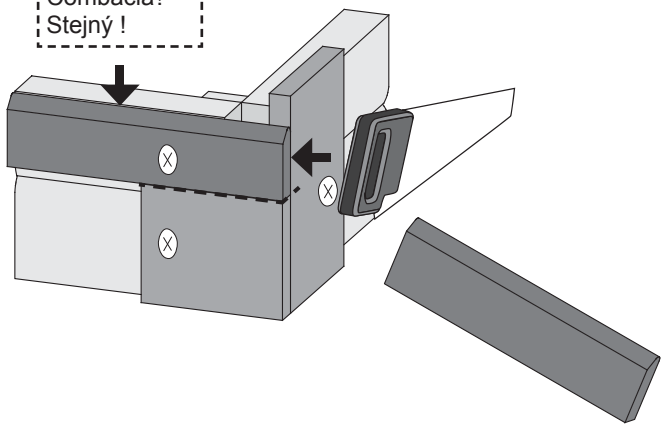

38

Ø3mm 4x50

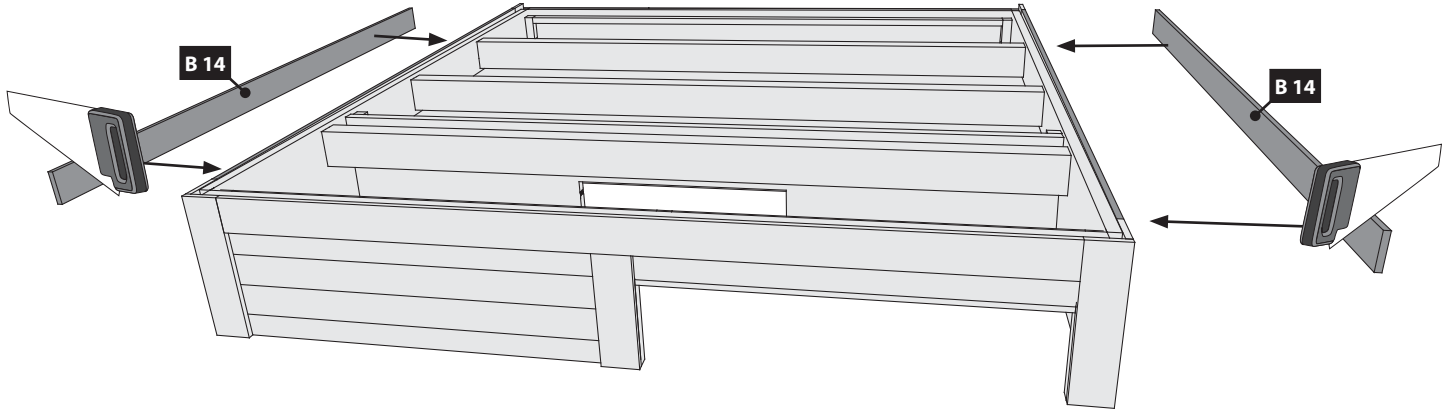
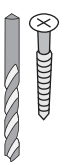
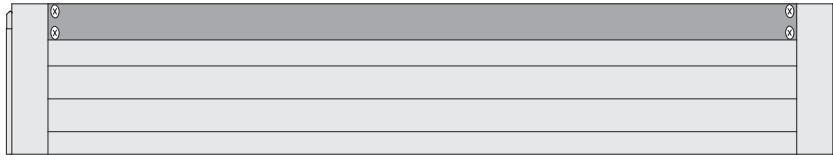

39

2x

Ø3mm 4x35

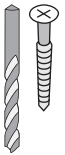
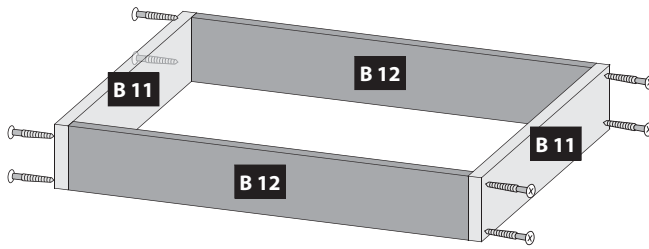

40

4x

Ø3mm 4x35

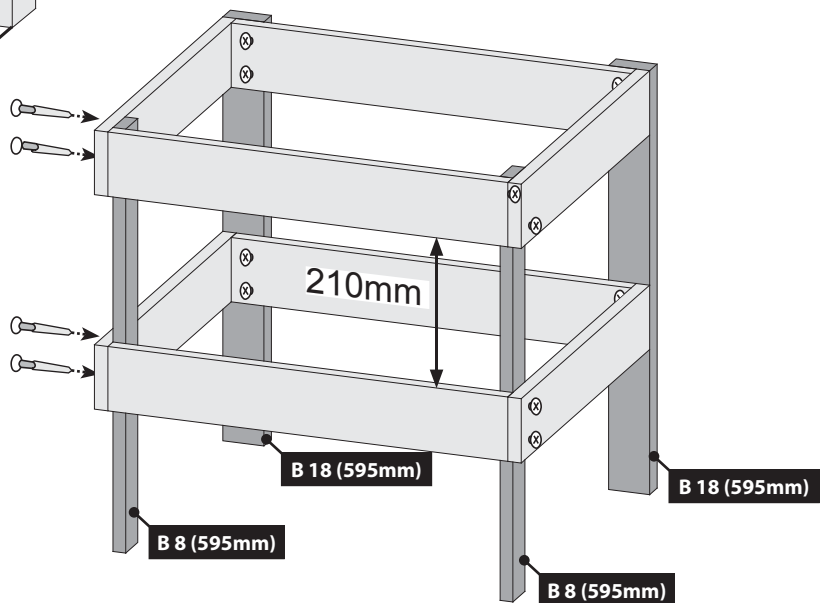
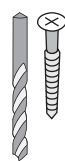
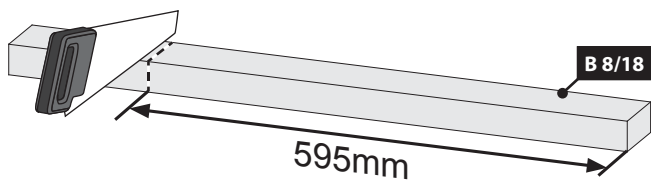



-  Breite Seite nach oben
-  Width side up
-  Largeur vers le haut
-  Breedte side up
-  Ancho de banda de hasta
-  Larghezza verso l'alto
-  Šířka stranou nahoru

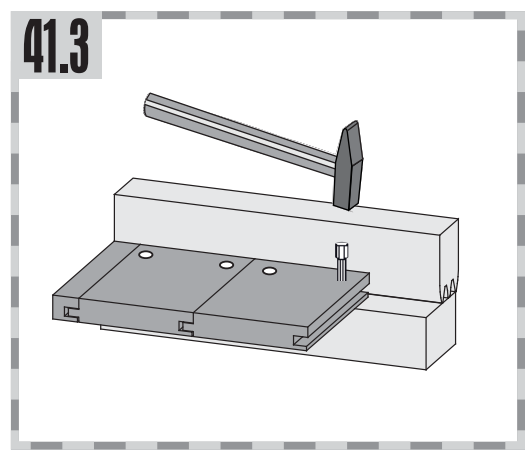
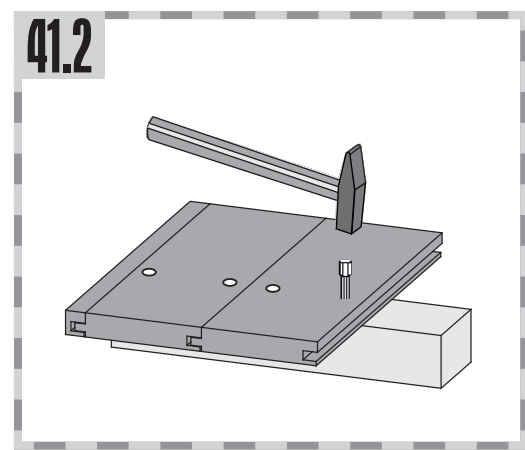
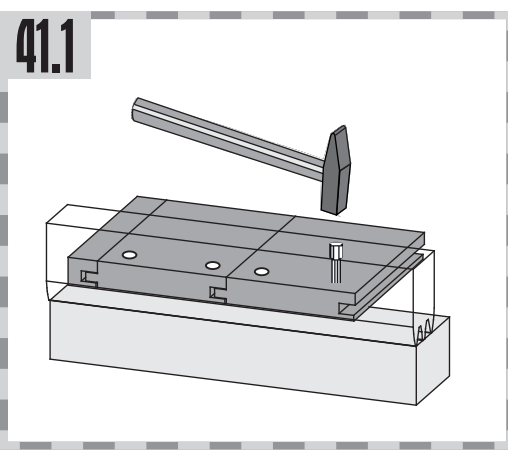
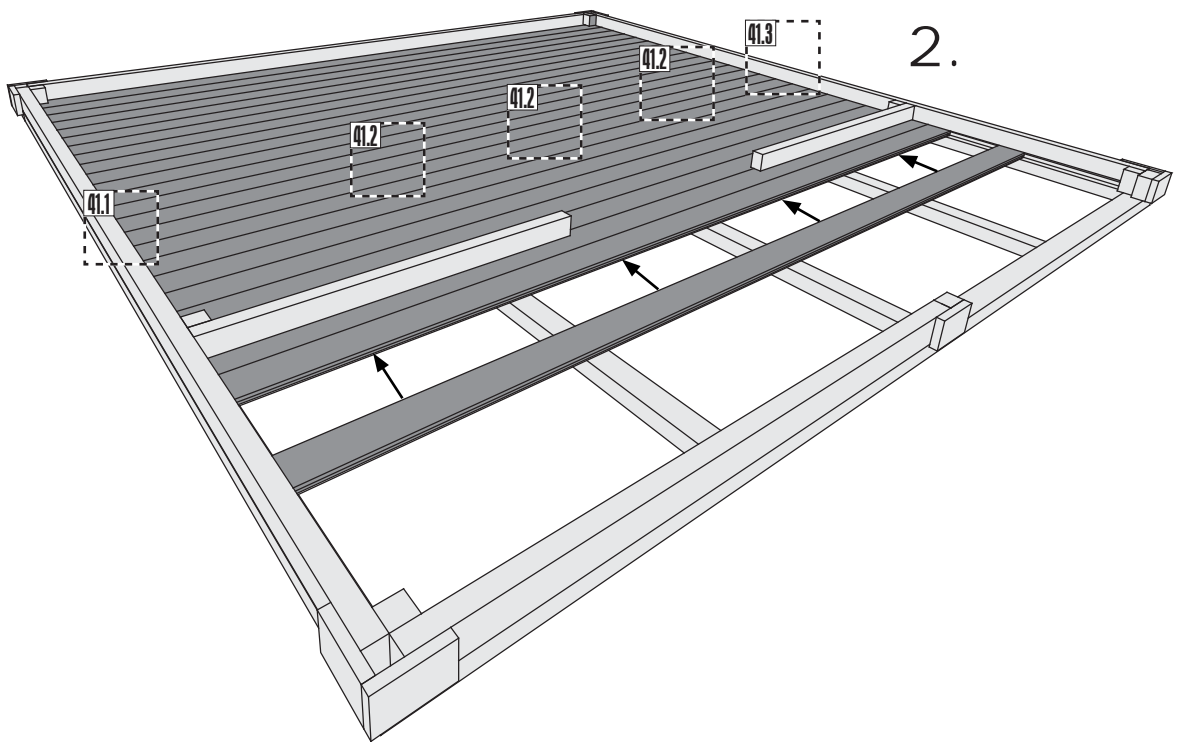
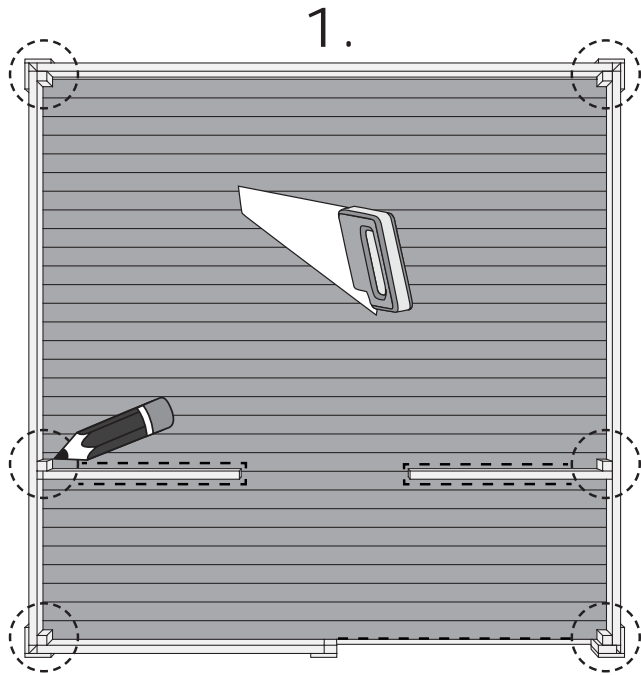

42

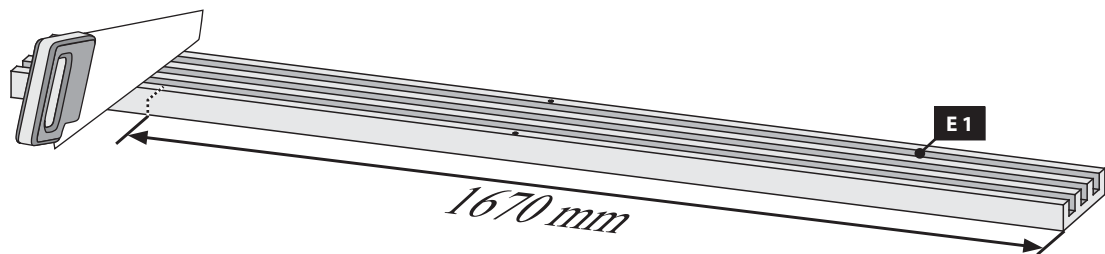

43



Ø3mm  4×50

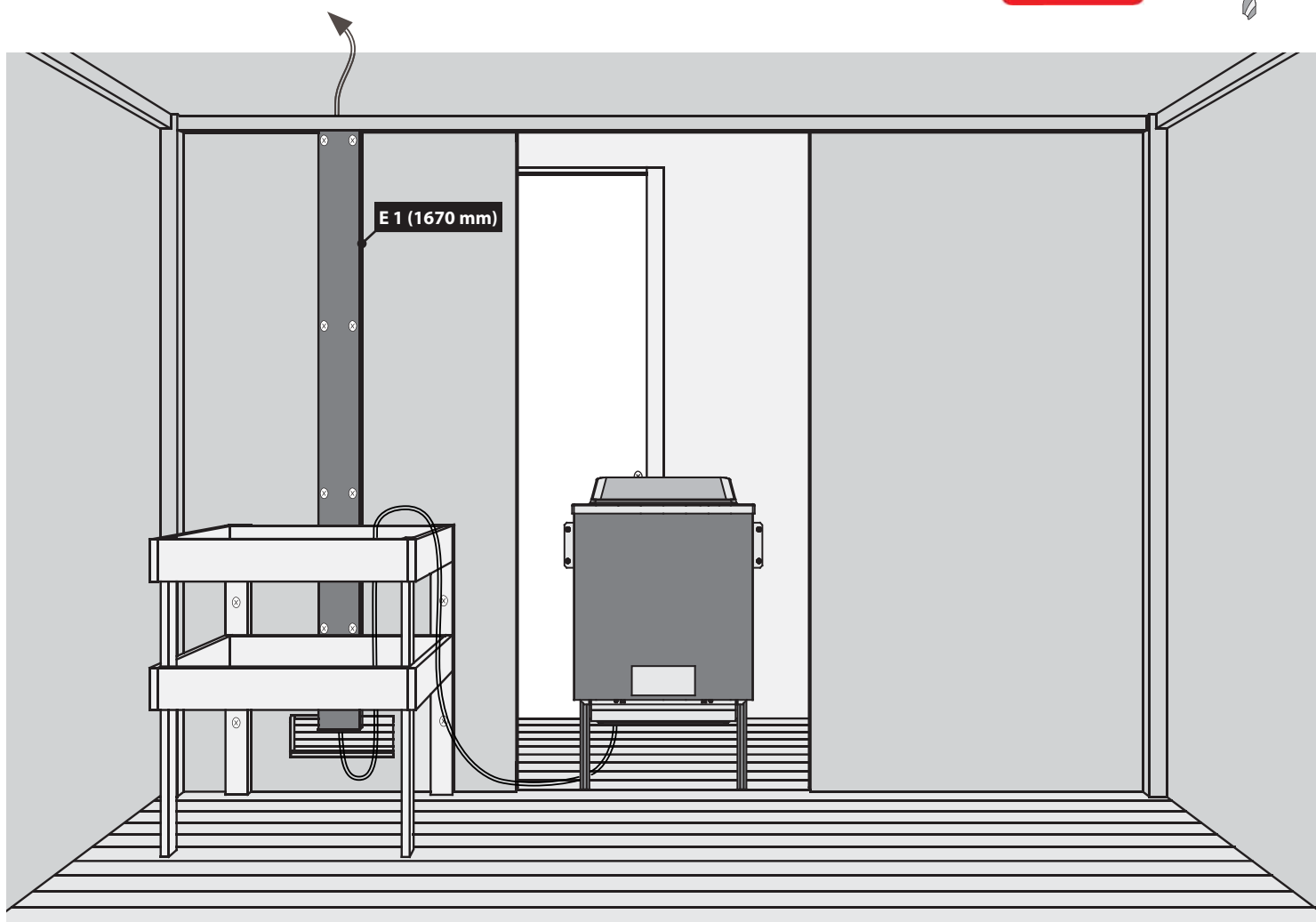

44

-  Ofenbefestigung
-  oven vaststelling
-  oven fixing
-  fixation four
-  fijación horno
-  fissaggio forno
-  upevňovací trouba

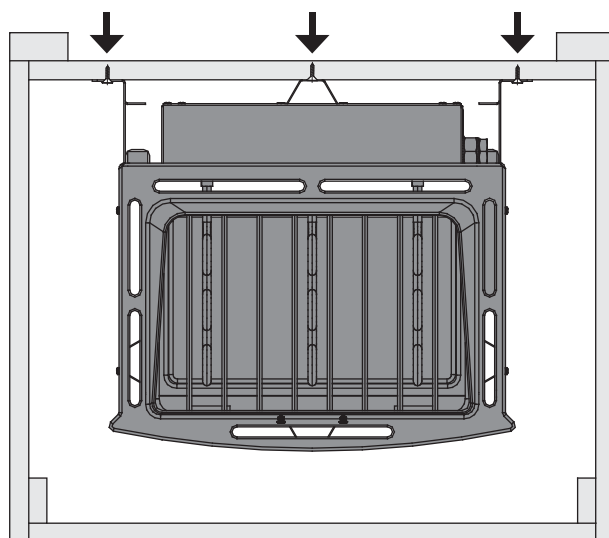
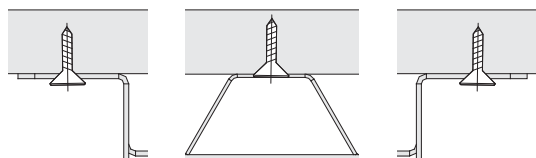

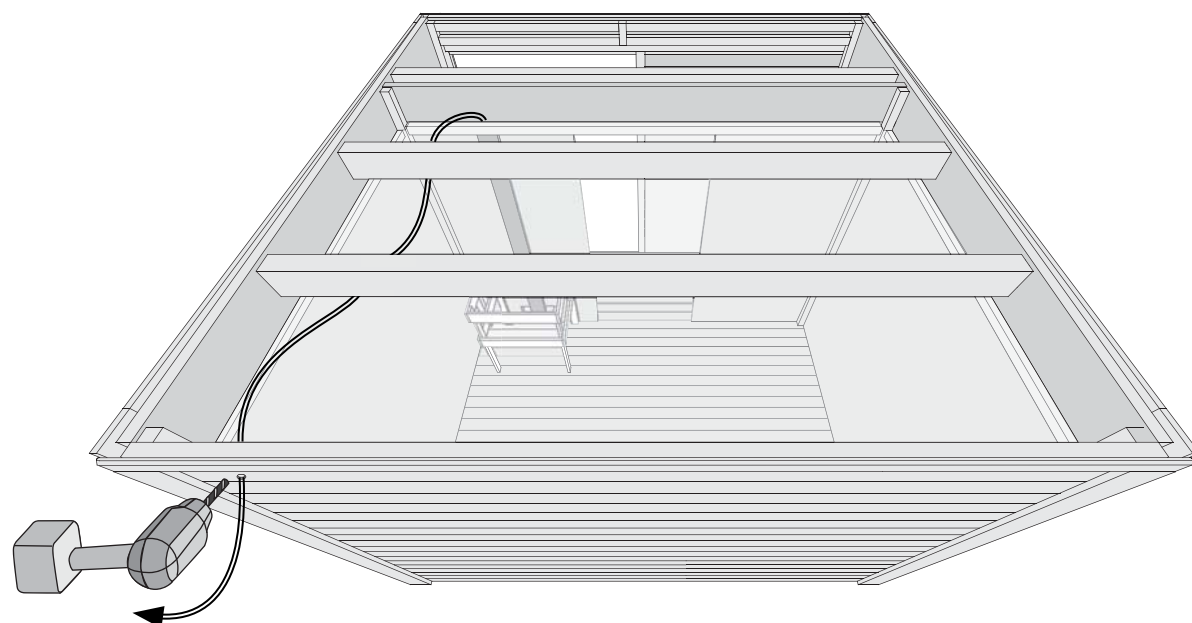

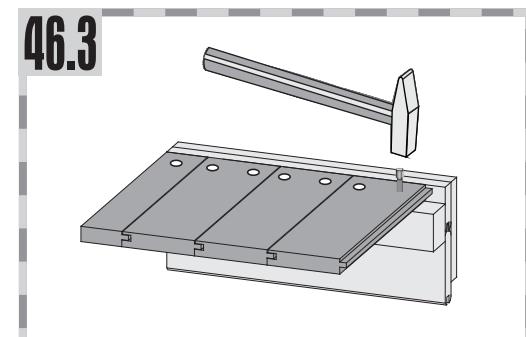
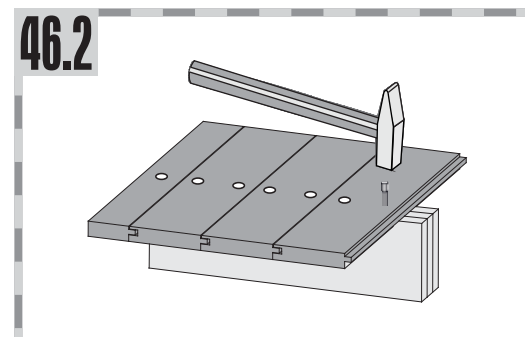
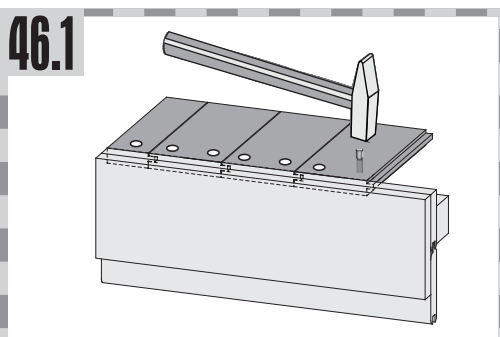
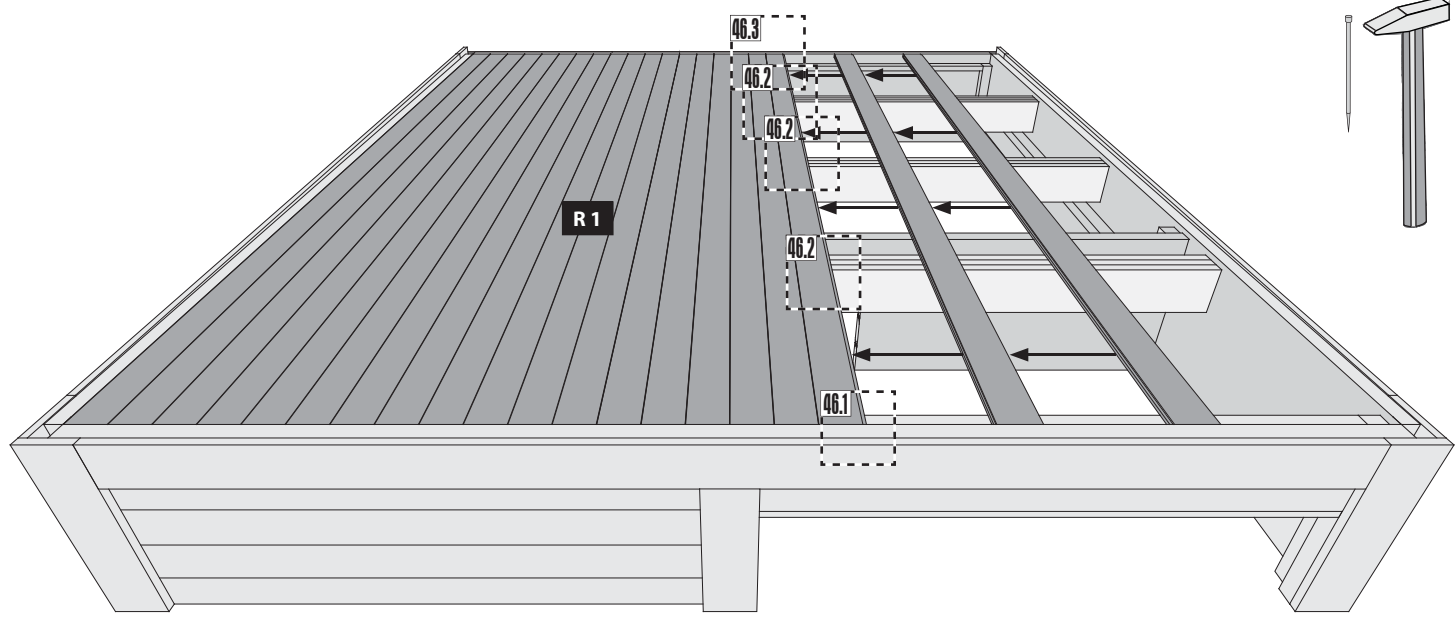
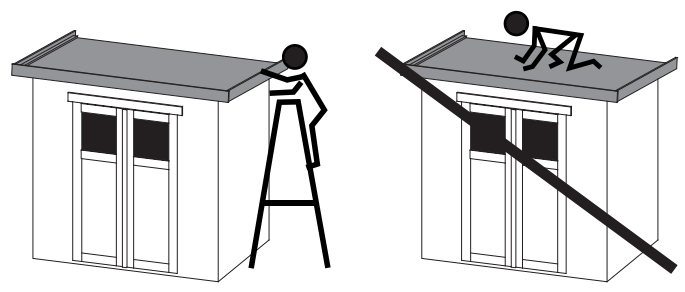

-  Schmale Seite nach oben
-  Estrecha hacia arriba
-  Narrow side up
-  Stretta verso l'alto
-  Narrow vers le haut
-  Úzká stranou nahoru
-  Smalle kant naar boven

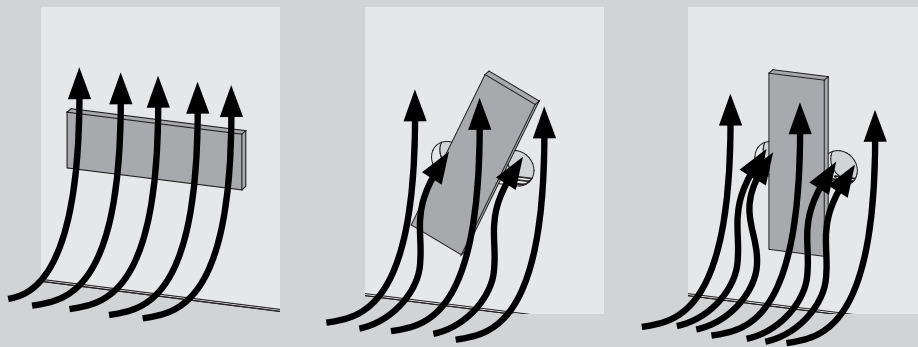
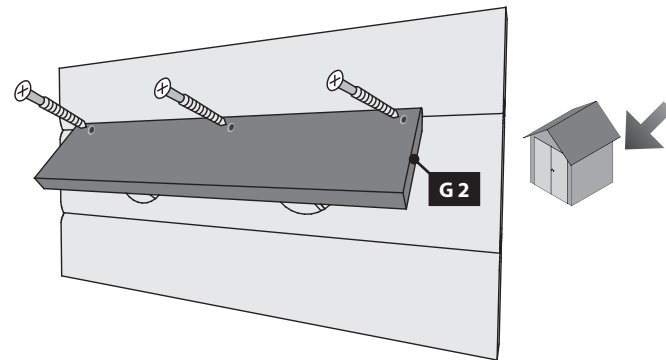
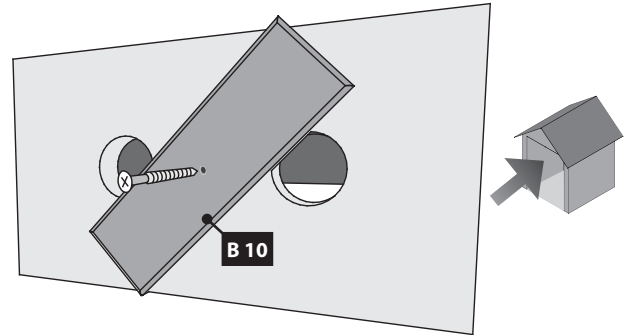
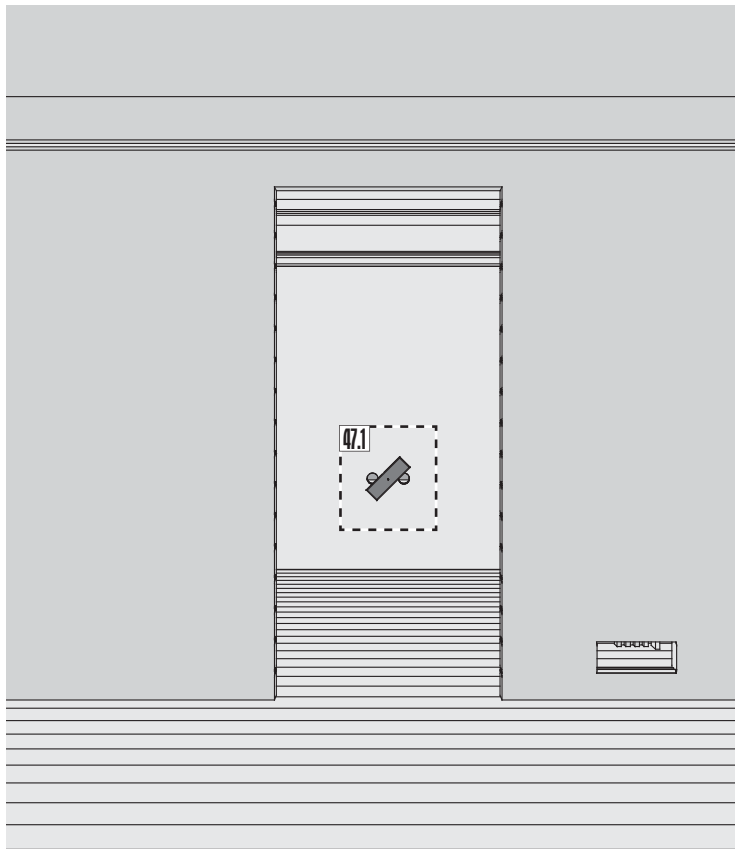





 Hier ist die Funktionsweise des Brettes abgebildet. Regeln Sie damit die Abluft nach Ihren eigenen Wünschen.

 Ceci représente le mode de fonctionnement de la planche. Avec elle, réglez l'écoulement de l'air selon vos désirs.

 This figure shows the functional principle of the board. Regulate the exhaust air according to your own wishes.



 Hier is de werking van het plankje afgebeeld. Regel daarmee de luchtafvoer naar eigen wens.



 Aquí está representada la forma de funcionamiento de la tabla. Regule con ello el aire de salida según sus propios deseos.



 Viene illustrato il principio di funzionamento della tavoletta di regolazione della ventilazione. Con essa si può regolare a piacere la ventilazione.

 Zde je zobrazená funkce desky. Regulujte s ní odsávací vzduch dle Vašeho přání.



 Einbau Glastür
 Montage porte en verre
 Installation of glass door

 Montage van de glazen deur
 Montaje de la puerta de cristal

 Installazione portello di vetro
 Sauna Instalace dveře

48

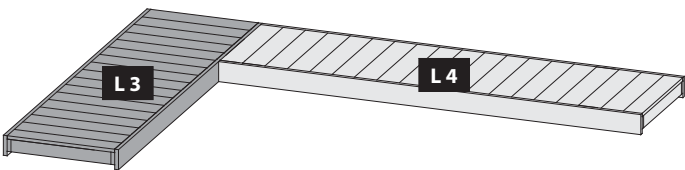

49

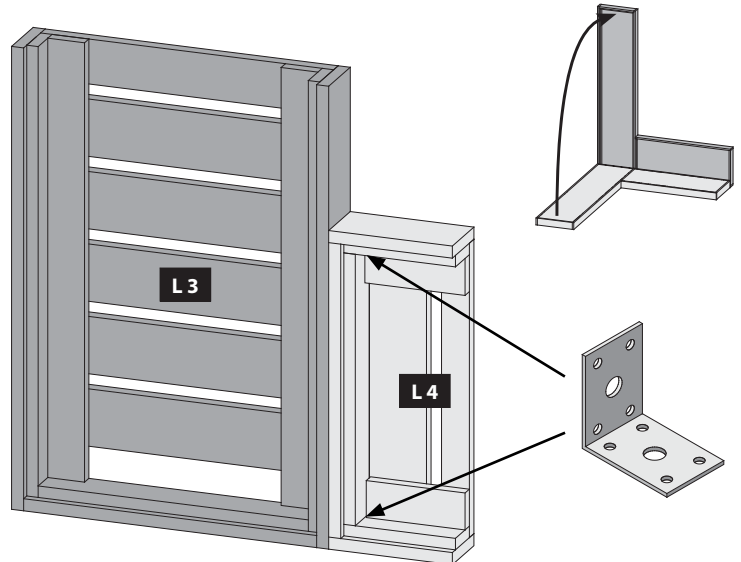

50

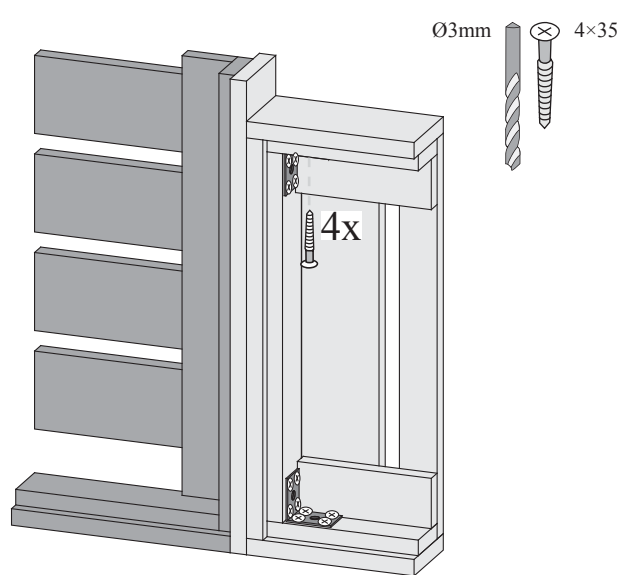

51

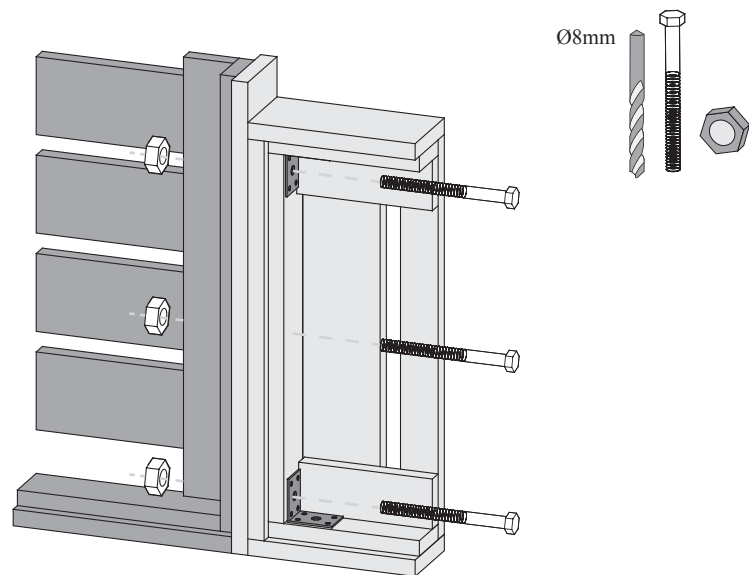

52

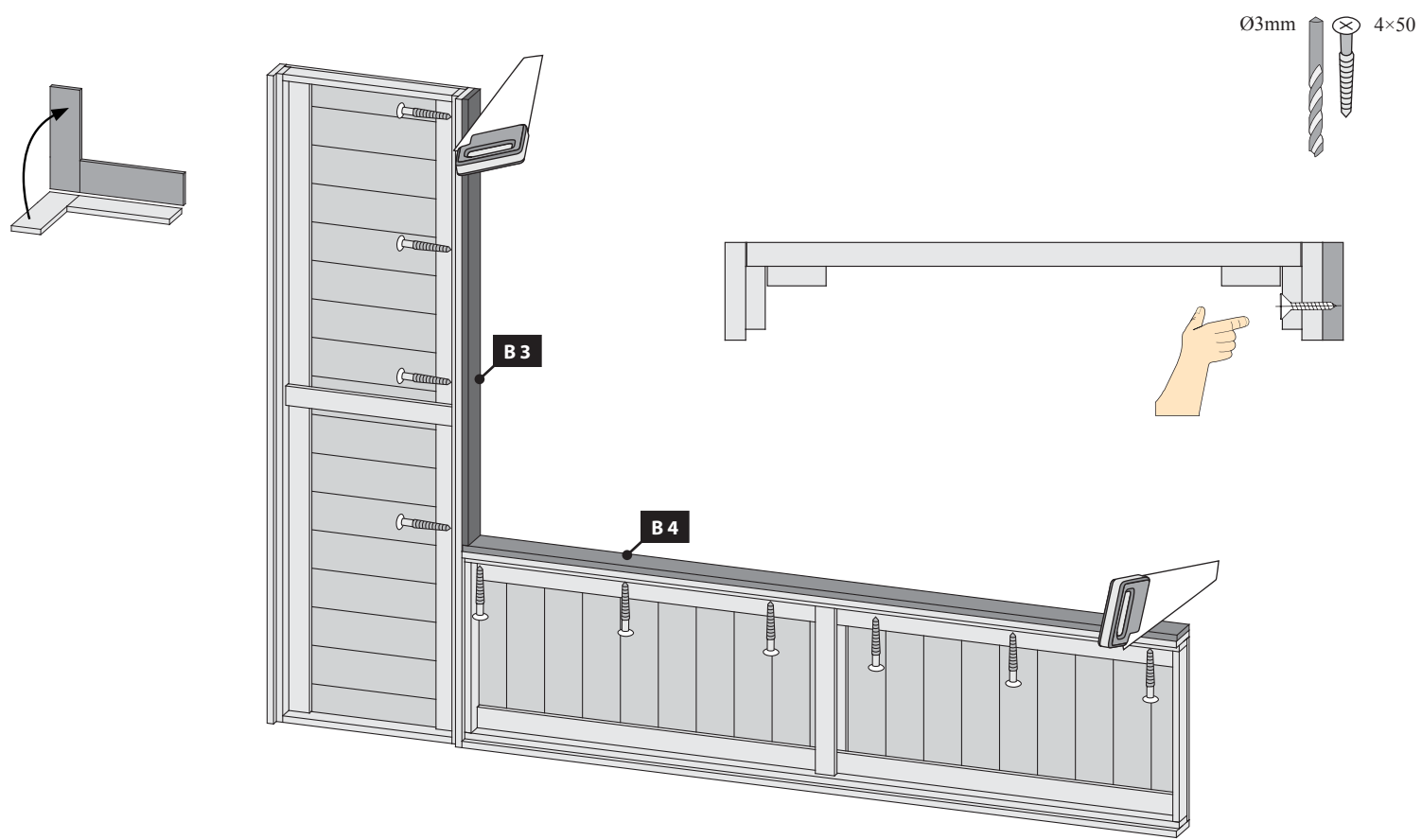

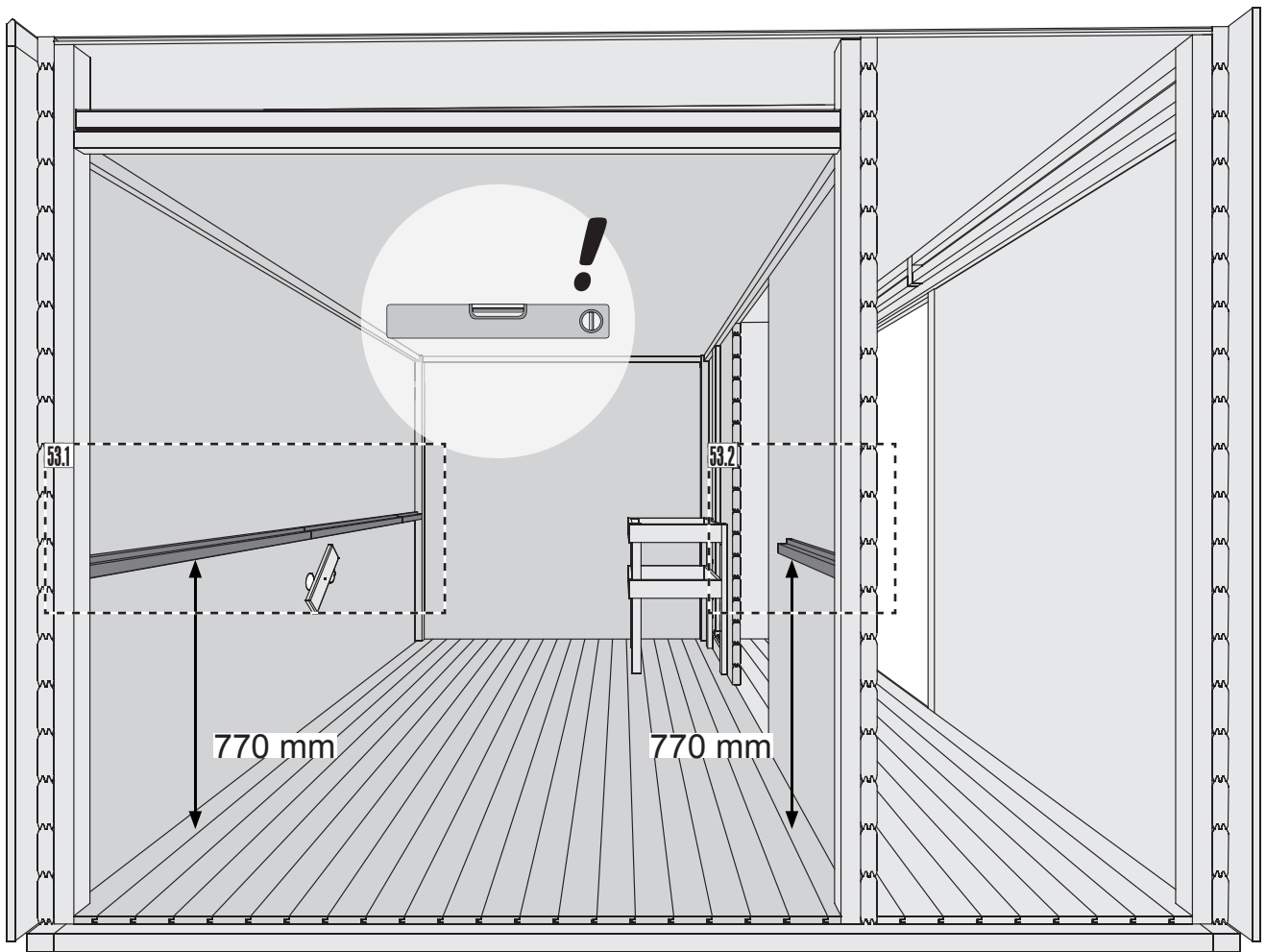

53.1

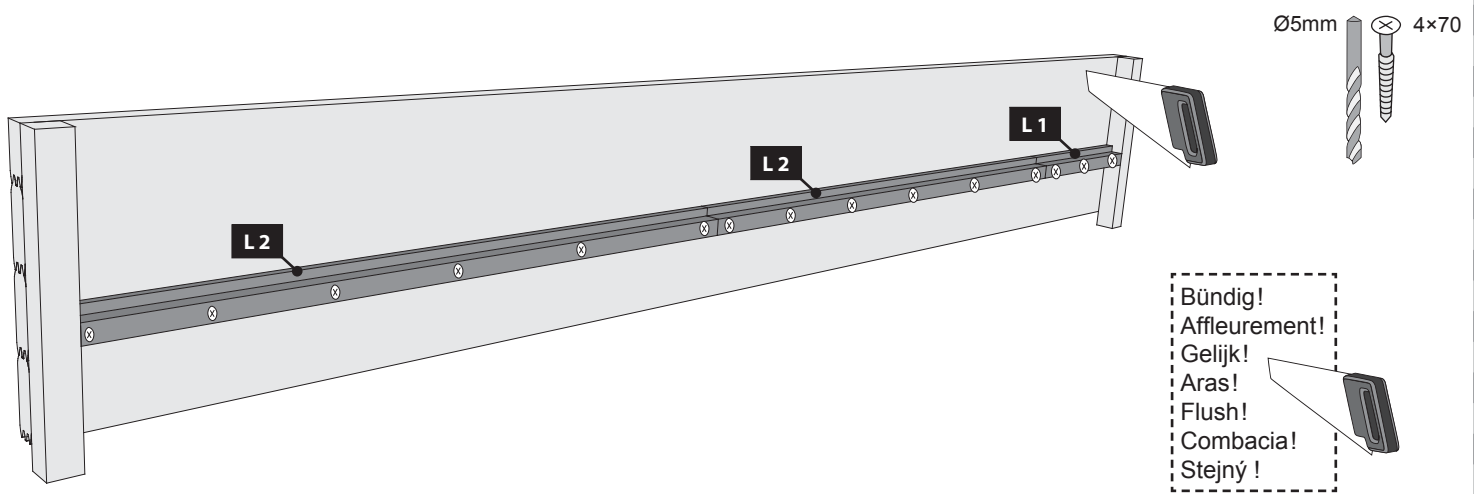

53.2

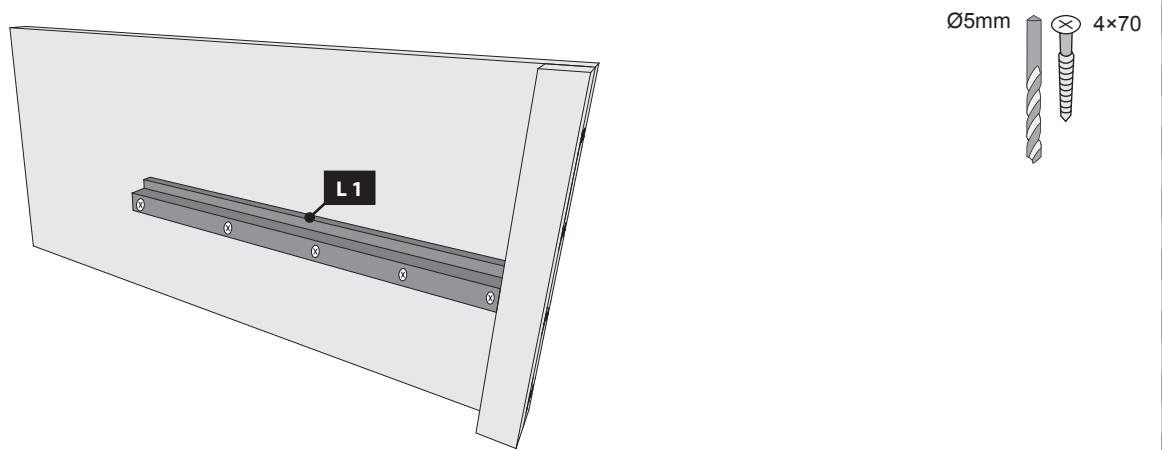

54 1x

Ø3mm 4×50

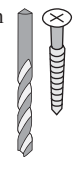
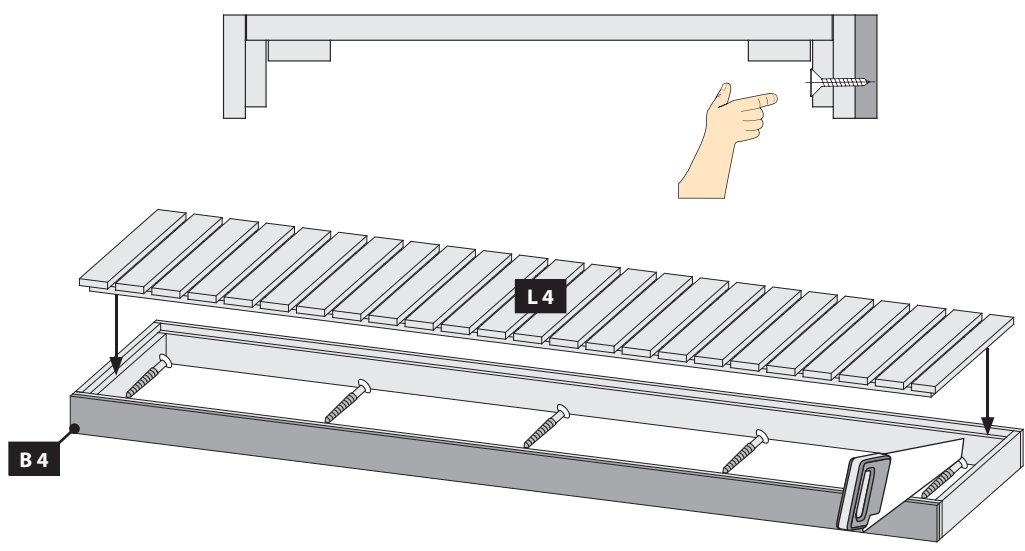

55

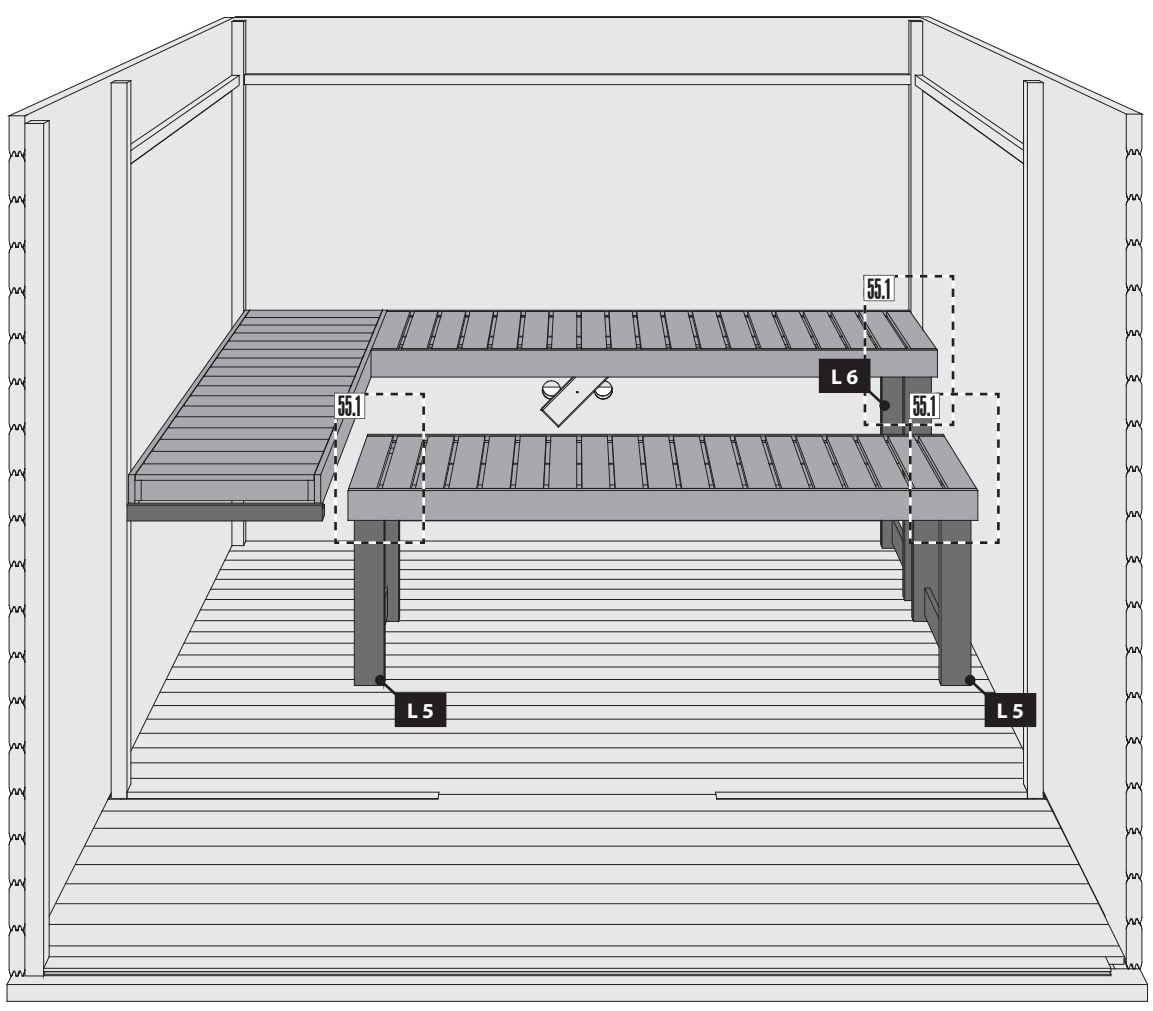

55.1

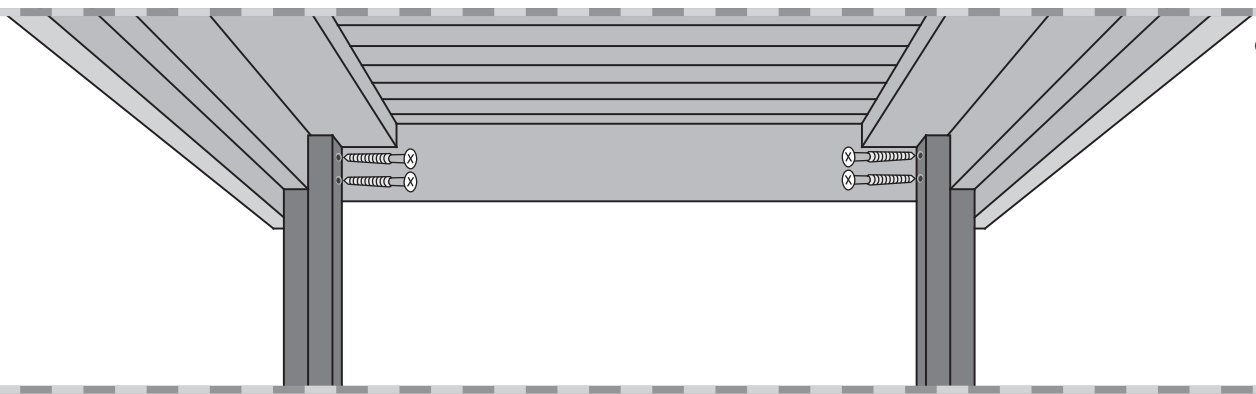

Ø3mm 4×50

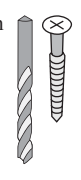

56

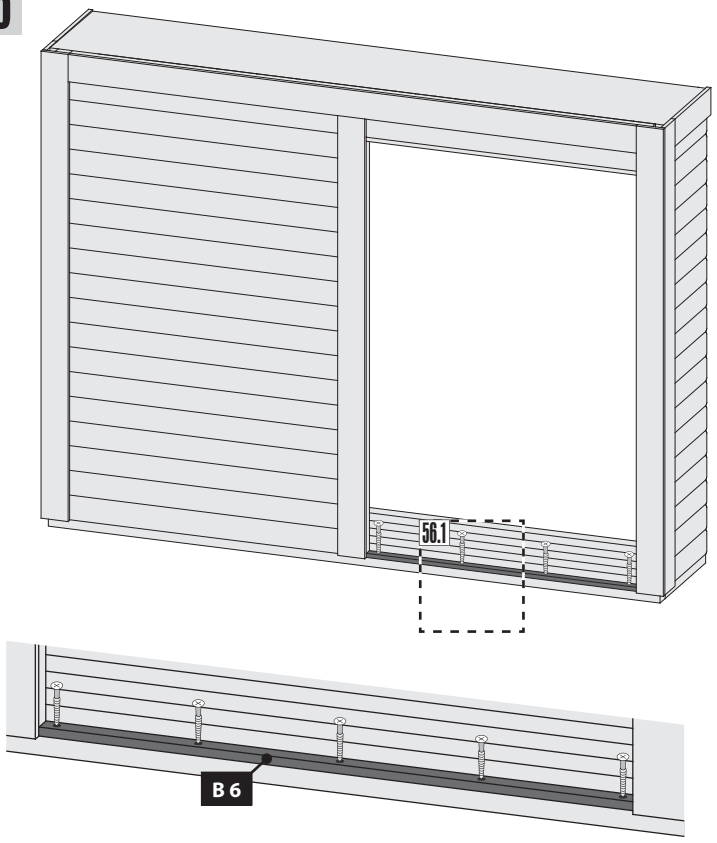

56.1

Ø3mm  4x50

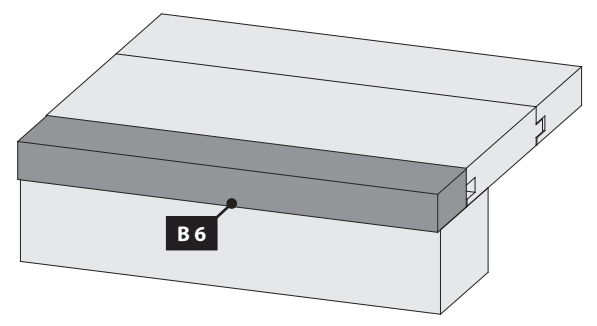
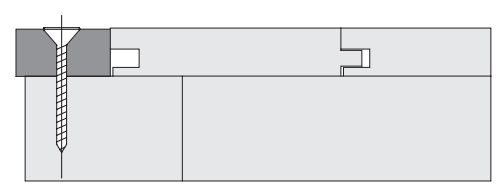

57

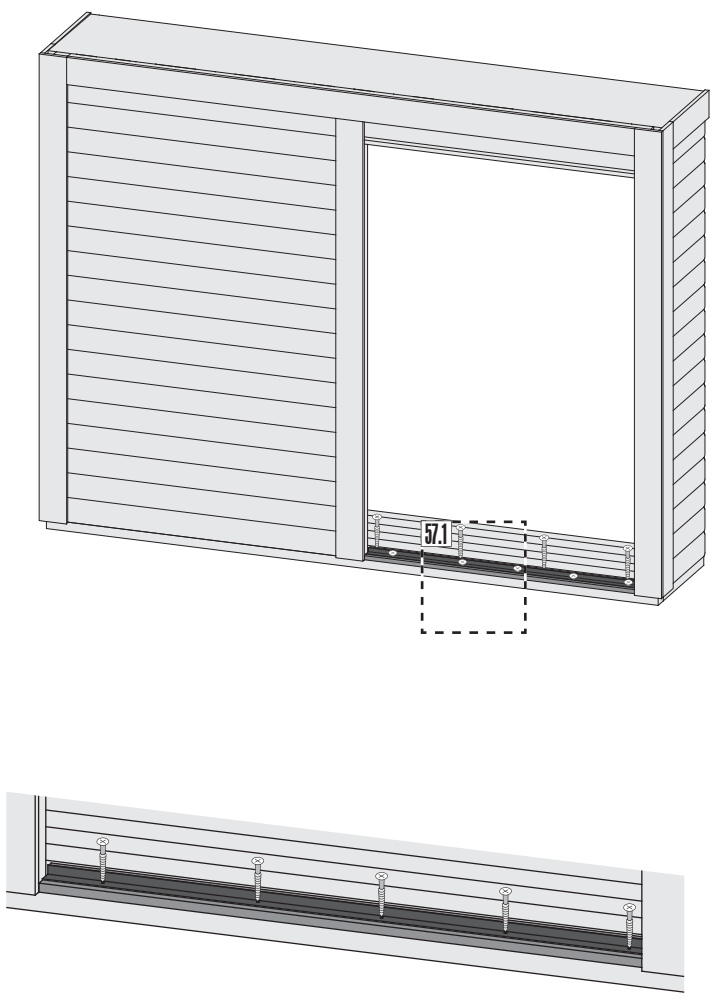

57.1

Ø3mm  4x35

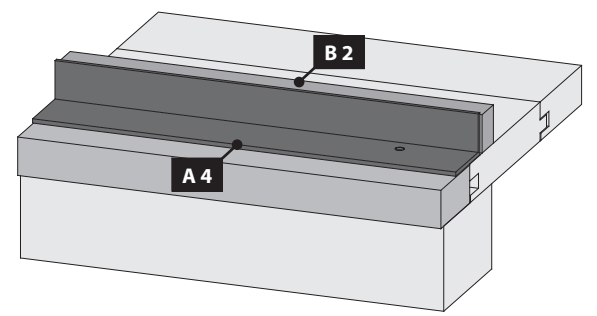
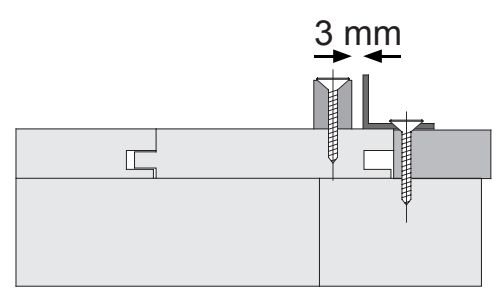
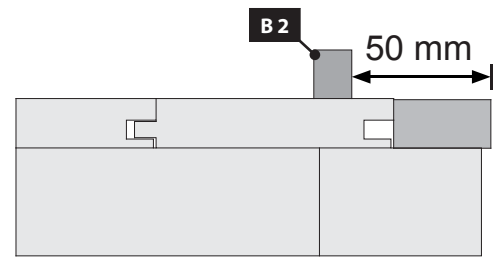

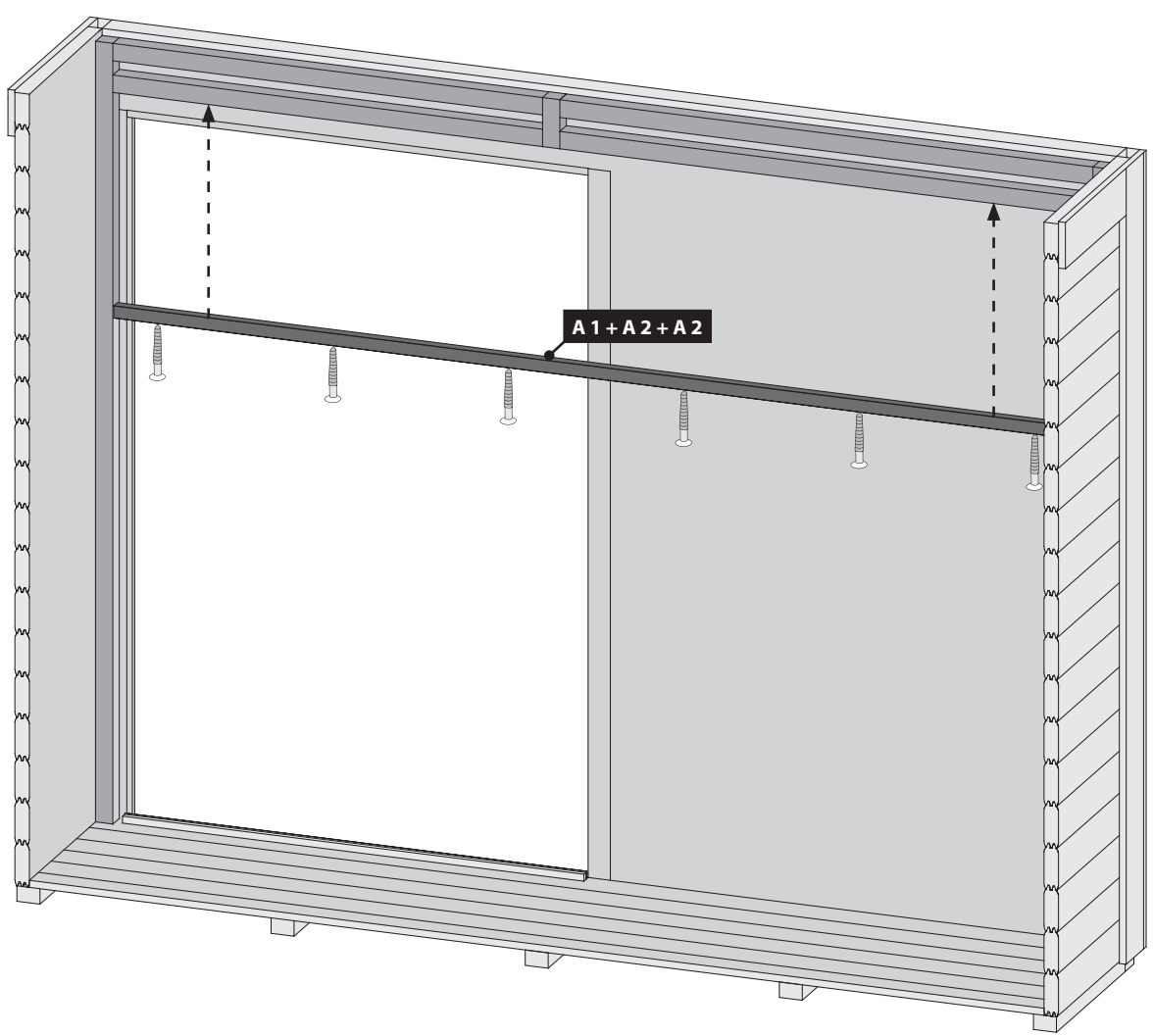
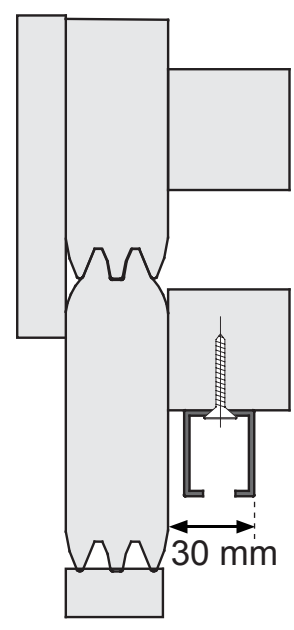
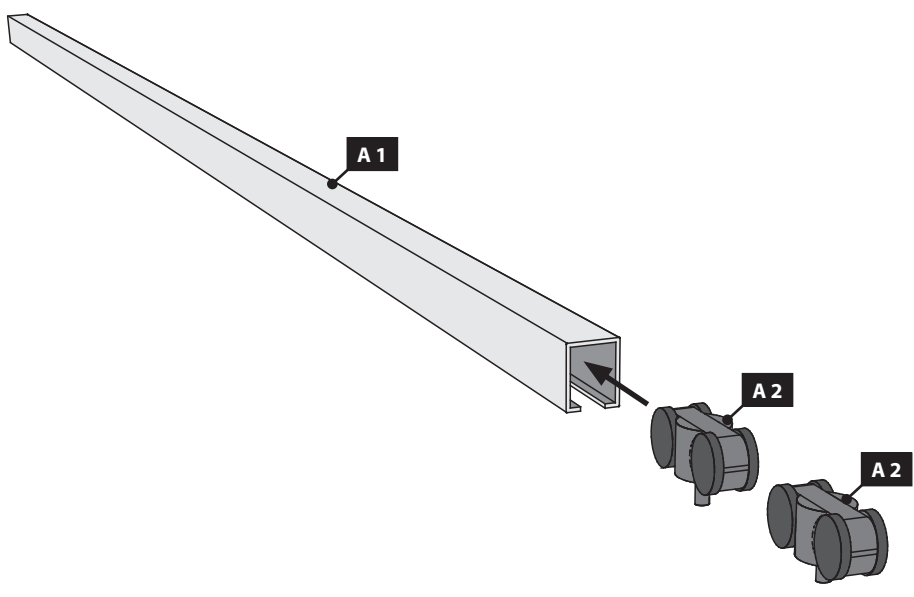
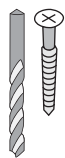

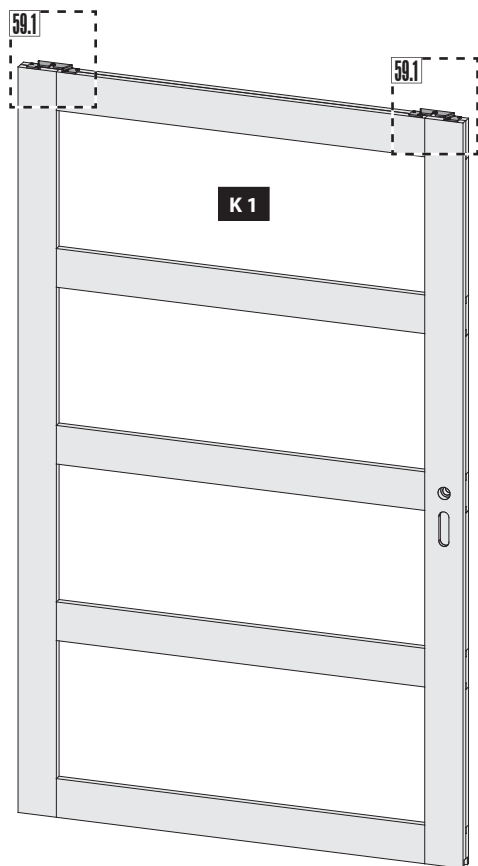

Ø3mm 4×35

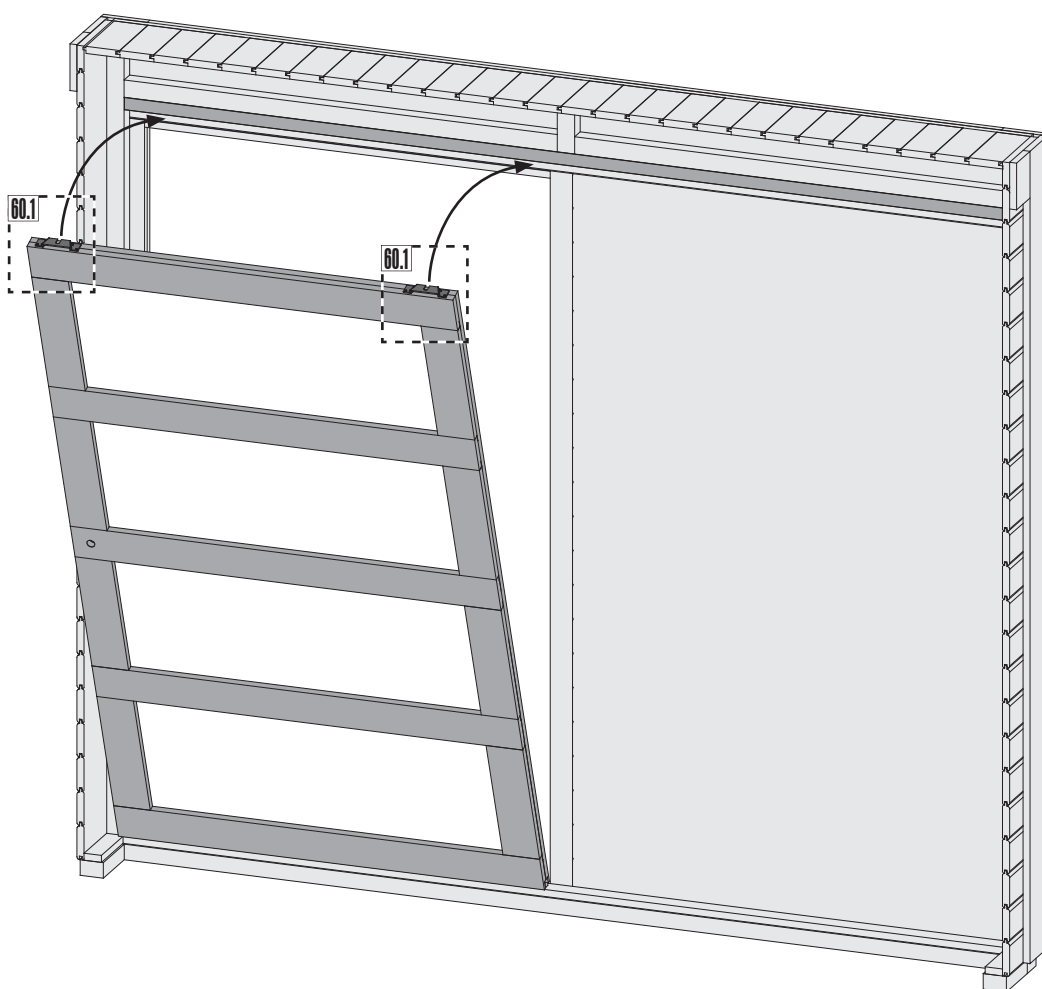
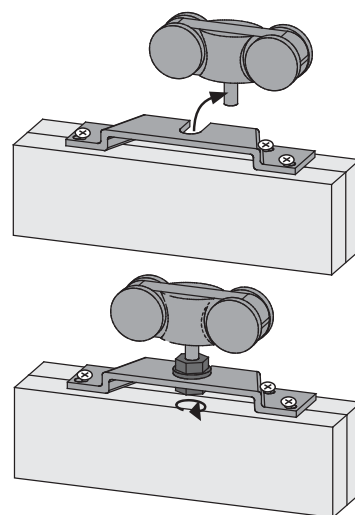
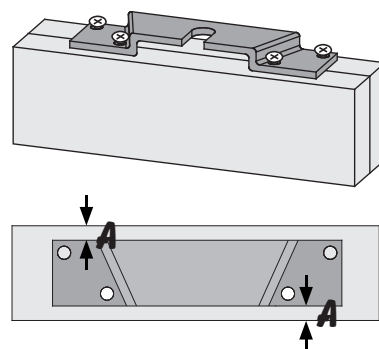

61

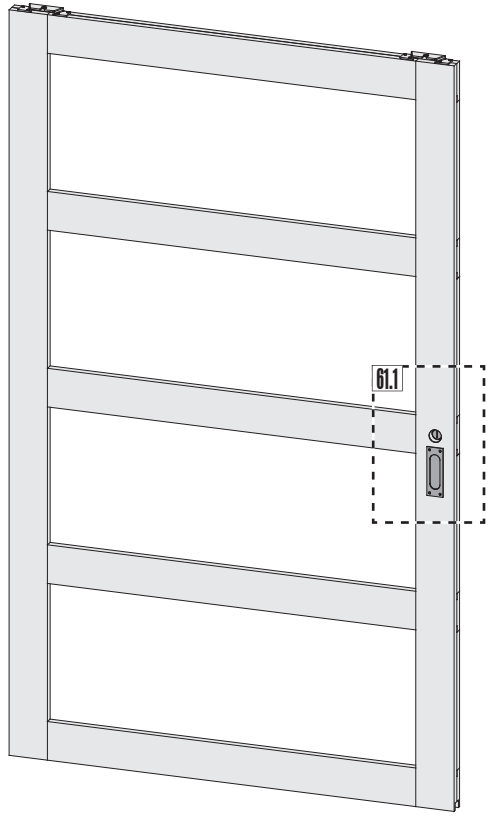

61.1-1

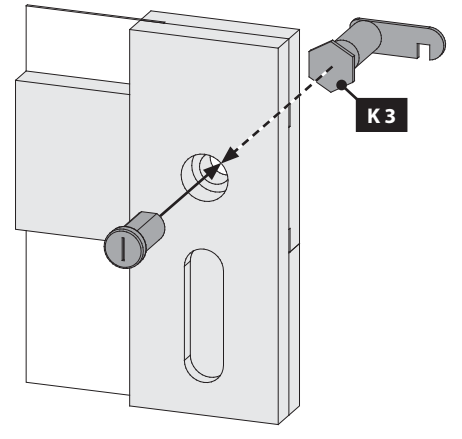

61.1-2

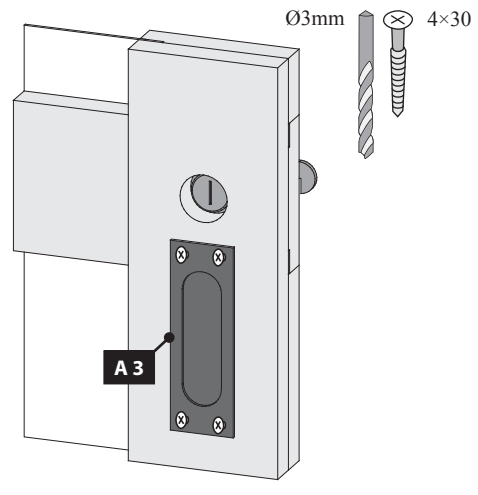

62

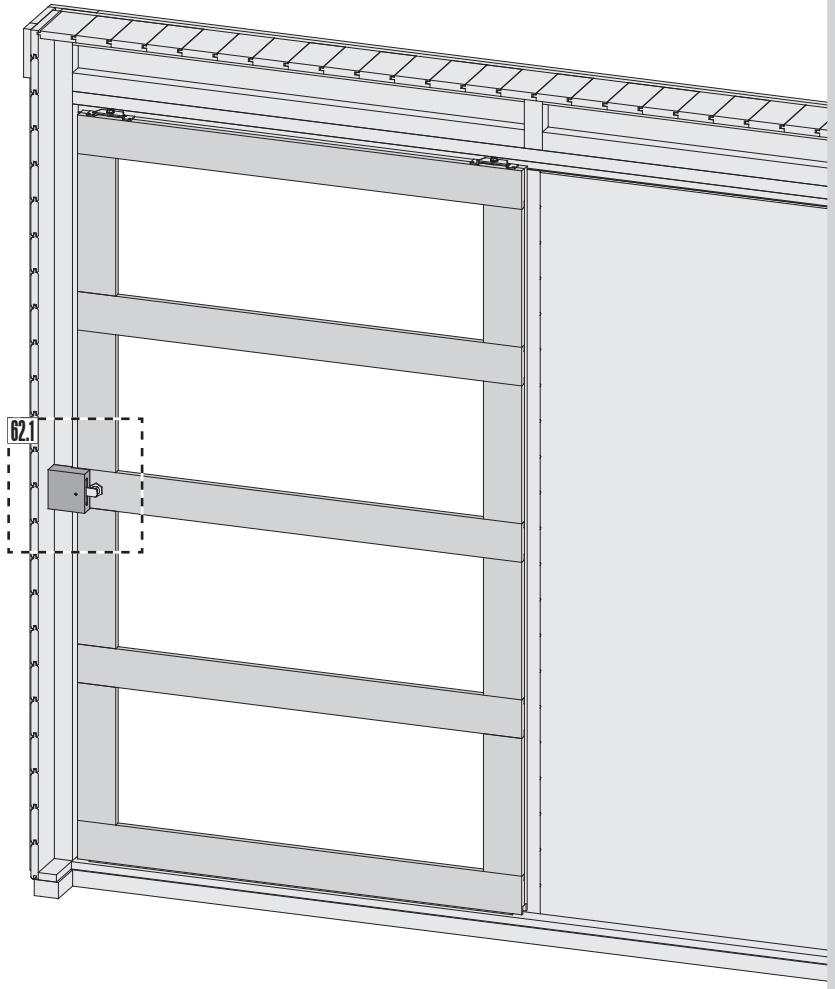

62.1

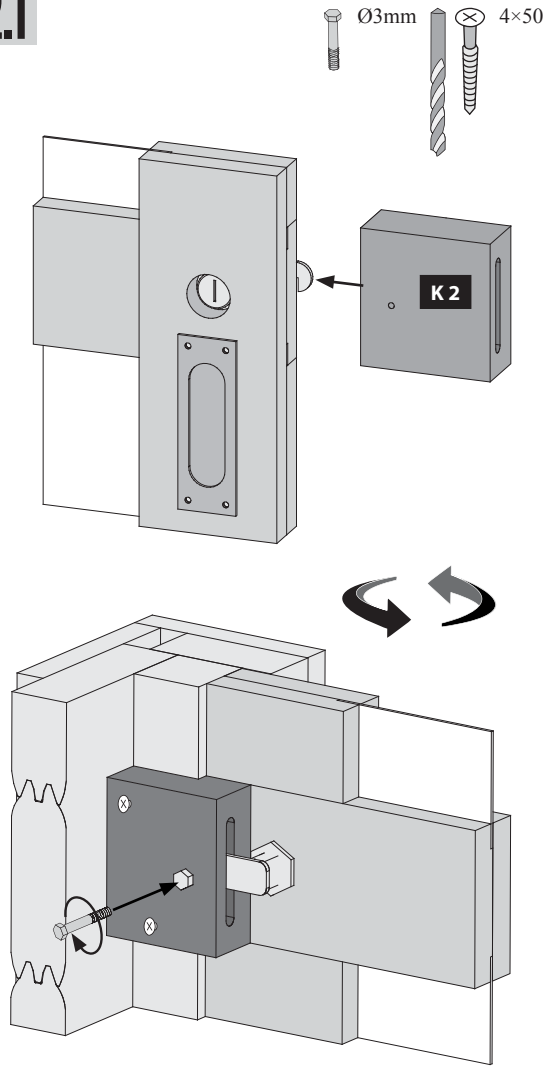

Verlegehinweis

Gardentop Stick Alu klebt auf Holzunterkonstruktionen, Metall, Bitumen, Beton, Mauerwerk und Kunststoffen (ausser PVC). Klebt nicht auf Silikon. Der Untergrund muss trocken, staub-, fettfrei und abriebfest sein.

Die Verarbeitungstemperatur sollte über 10 Grad Celsius betragen. Lagern Sie die Bahn bei kalten Jahreszeiten vor der Verarbeitung nicht im Freien. Eine optimale Verklebung erreichen Sie bei höheren Temperaturen. Achten Sie darauf, dass Sie Unebenheiten vor dem Aufbringen der Bahn ausgleichen.

Vor der Verlegung sollte geprüft werden, ob das Produkt für den Einsatzbereich geeignet ist.

Bei verschmutztem Untergrund muss ein bituminöser Voranstrich (lösemittelhaltig oder lösemittelfrei) aufgebracht werden.

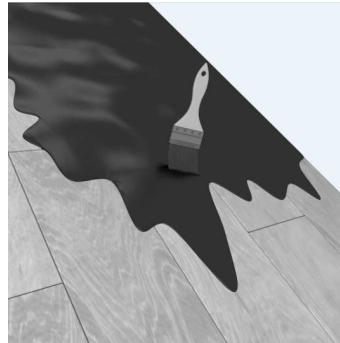

- Das Verlegen der Bahnen erfolgt längs oder quer mit einer Mindestüberlappung von 10 cm. Vor dem Abziehen der unterseitigen Folie, rollen Sie die Bahn ca. 2 m aus, um die Bahn seitlich auszurichten. Dann klappen Sie den Rollenanfang um und ziehen die Schutzfolie auf der Bahnenunterseite ca. 20 cm ab, um die Bahn so mit der Selbstklebefläche auf dem Untergrund zu fixieren (Bild 1).
- Anschließend rollen Sie die Bahn wieder zurück, bis zum verklebten/fixierten Rollenanfang.
- Rollen Sie die Bahn nun durch abziehen der unterseitigen Folie gleichmäßig aus (Bild 2) und achten Sie darauf, dass es keine Lufteinschlüsse gibt. Lufteinschlüsse sind gleichmäßig nach außen weg zu bürsten.
- Achten Sie besonders im Überdeckungsbereich darauf, dass eine gute Verklebung eintritt. Sie können die beste Klebewirkung mit einer Anpresswalze erreichen (Bild 3).

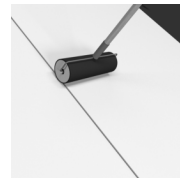
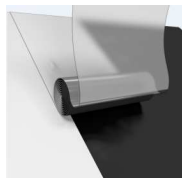
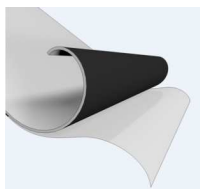

Gardentop STICK ALU 5 x 1m

Edition: 18/02/2016

EINSATZBEREICH / Produkt

Kaltselbstklebende, oberseitig alukaschierte Dachbahn, zur Dacheindeckung von untergeordneten Dächern, wie z. B. von Carports, Gartenhäusern, Geräteschuppen, usw.

ZUSAMMENSETZUNG

Oberseitige Deckschicht und Träger: UV – beständiger Aluminiumverbund
Unterseitige Deckschicht: Thermoplastischer Bitumenklebstoff mit silikonisierter Abziehfolie

BESCHICHTUNG

Oberseite: UV- beständiger Aluminiumverbund
Unterseite: silikonisierte Folie

ABMESSUNGEN

Länge: 5 (±1%) x 1(±1%) m
Dicke: 1,1 mm (±5%)
Gewicht / Dachbahn: ± 6 kg

VERPACKUNG

*Rollen / Palette: 54 (270 m²),
jede Rolle einzeln in Kartonverpackung, mit Aufdruck der Produktbezeichnung, -erklärung und Verlegehinweisen*

TECHNISCHE INFO

	<i>Höchstzugkraft</i>		<i>Wärmestand-</i>
	<i>Länge</i>	<i>Breite</i>	<i>festigkeit bei 80°C</i>
<i>Minimalwerte</i>	$\geq 200N$	$\geq 200N$	$< 2mm$
	<i>Wasserdampf-</i>		<i>Brandklasse</i>
	<i>Durchlässigkeit sd</i>		
<i>Minimalwerte</i>	$>1500 m$		<i>E</i>

63 1x

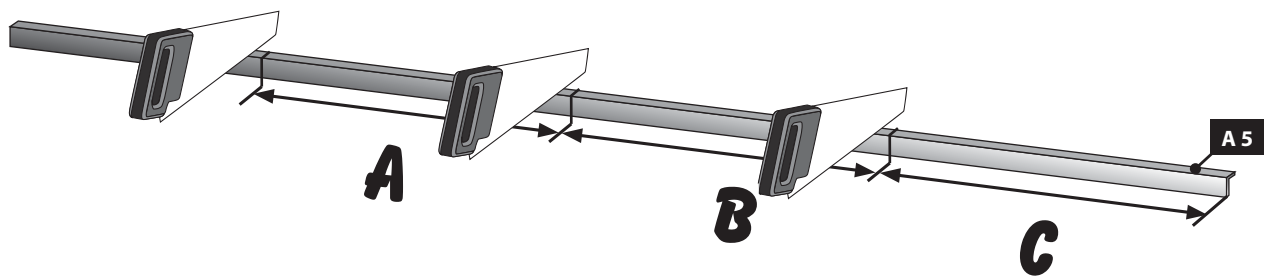

64

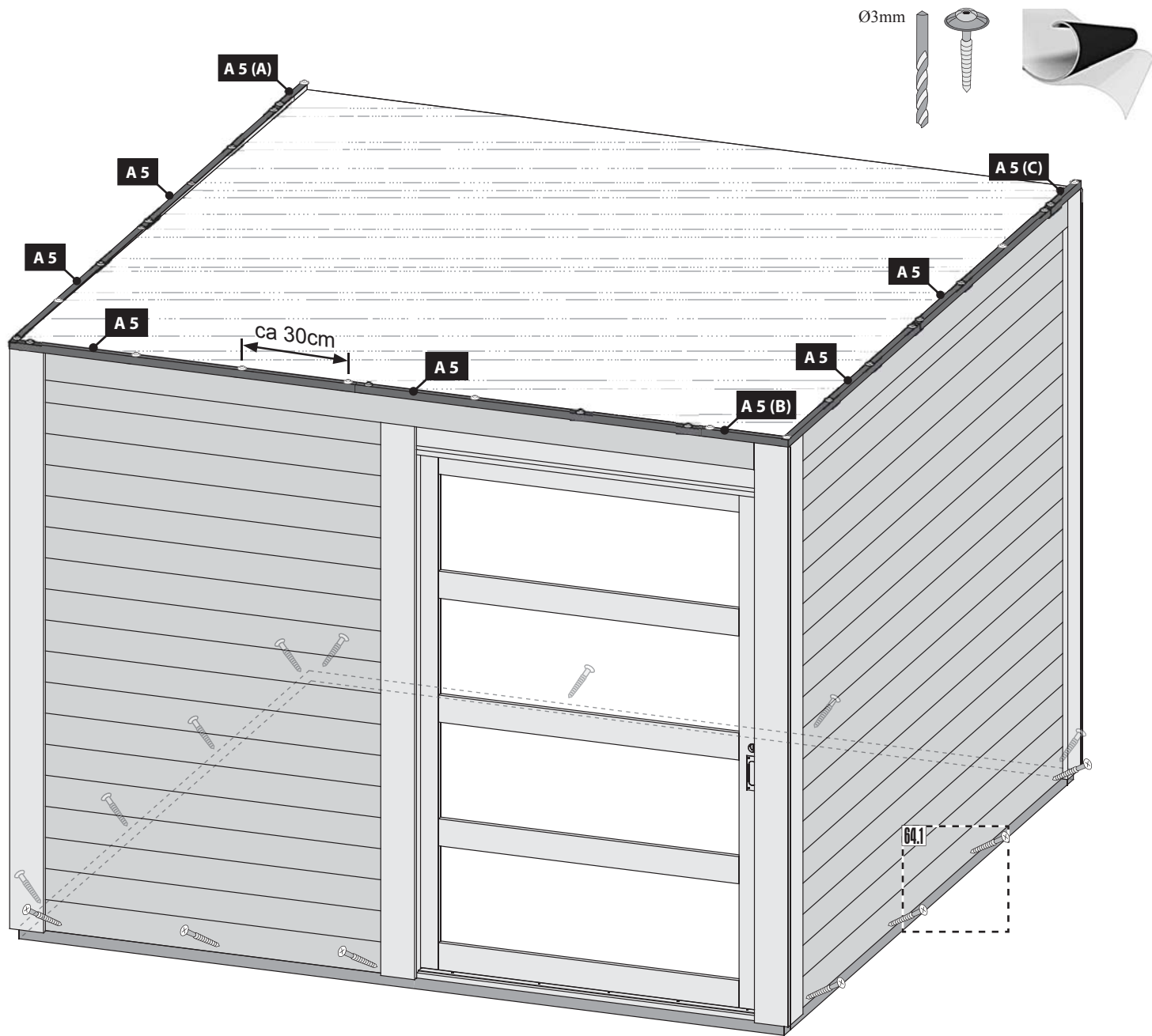

64.1

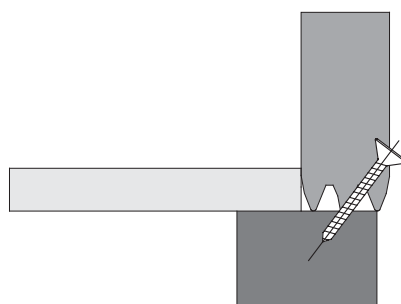
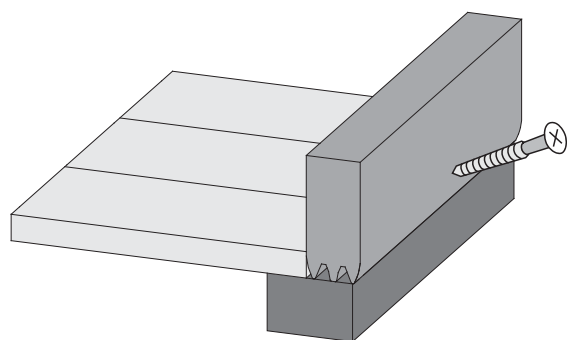

Ø3mm 4×70

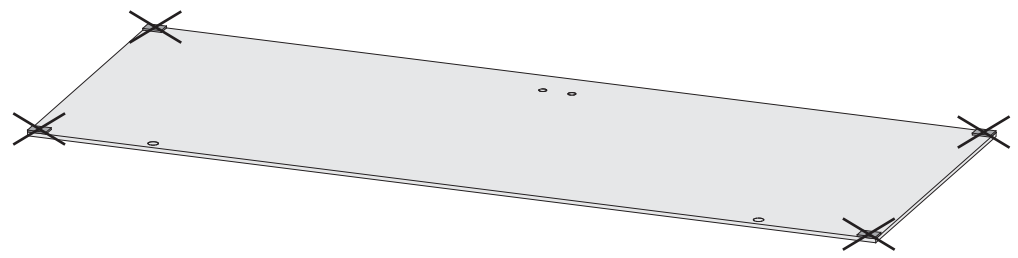
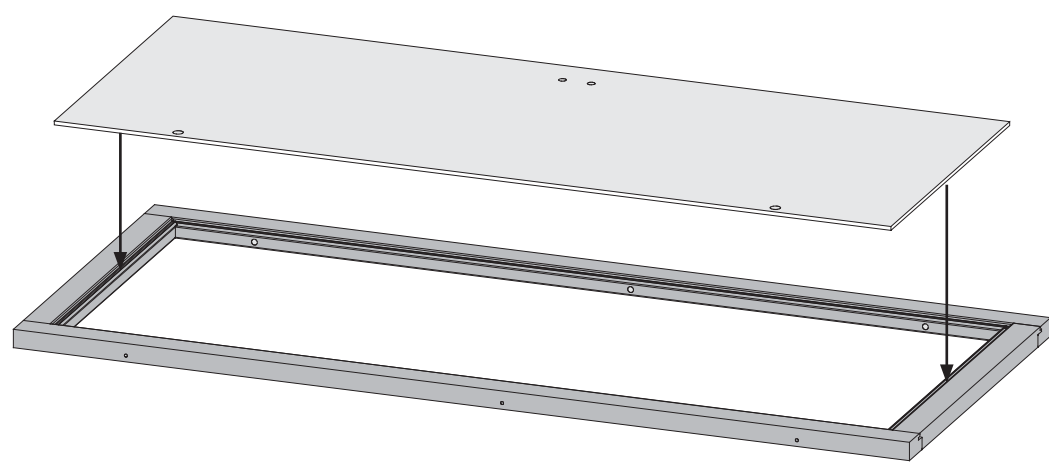
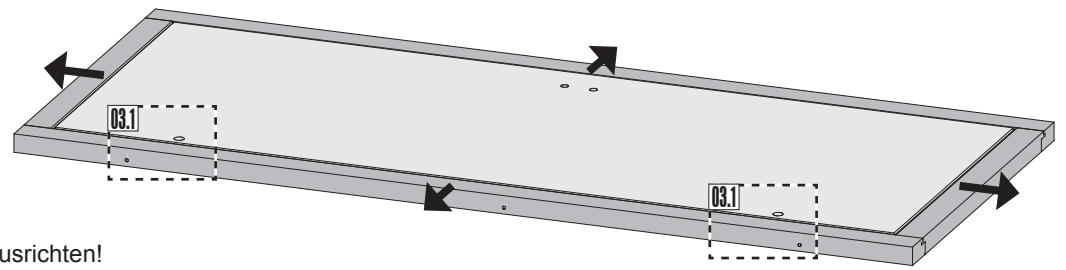
01**02****03**

- Das Saunatürglas im Türrahmen ausrichten!
- Bien aligner le verre à vitre!
- To start building up the door you need to center the glass in the wooden frame!
- Plaats het glas van de sauna deur in het midden van het kozijn!
- ¡Centrar la puerta de cristal dentro del marco!
- Allineare il vetro dello sportello sauna al telaio della porta!
- Skleněná dvířka sauna v zárubně zarovnáni!

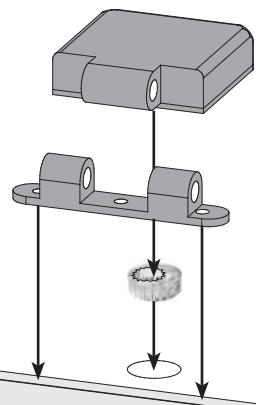
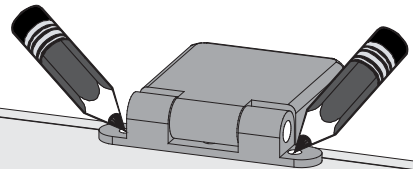
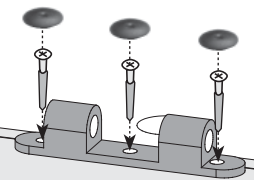
03.1-1**03.1-2****03.1-3**

 Einbau Saunatür

 Sauna deur installatie

 Sauna Instalace dveře

 Installation de porte Sauna

 Instalación de la puerta Sauna

 Sauna door installation

 Installazione porta Sauna

04

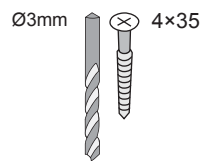
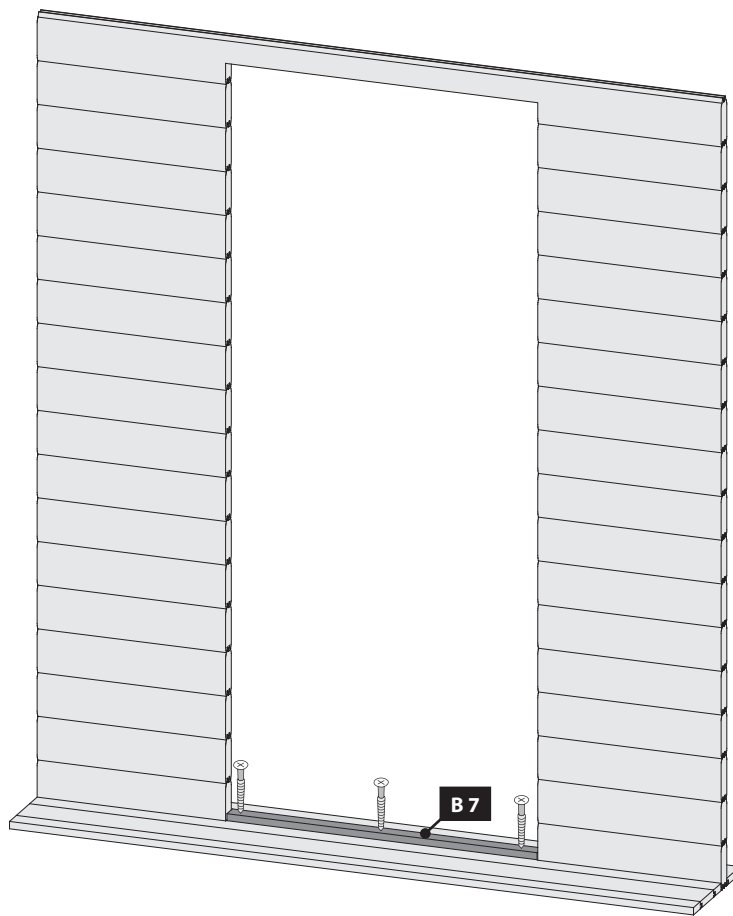

05

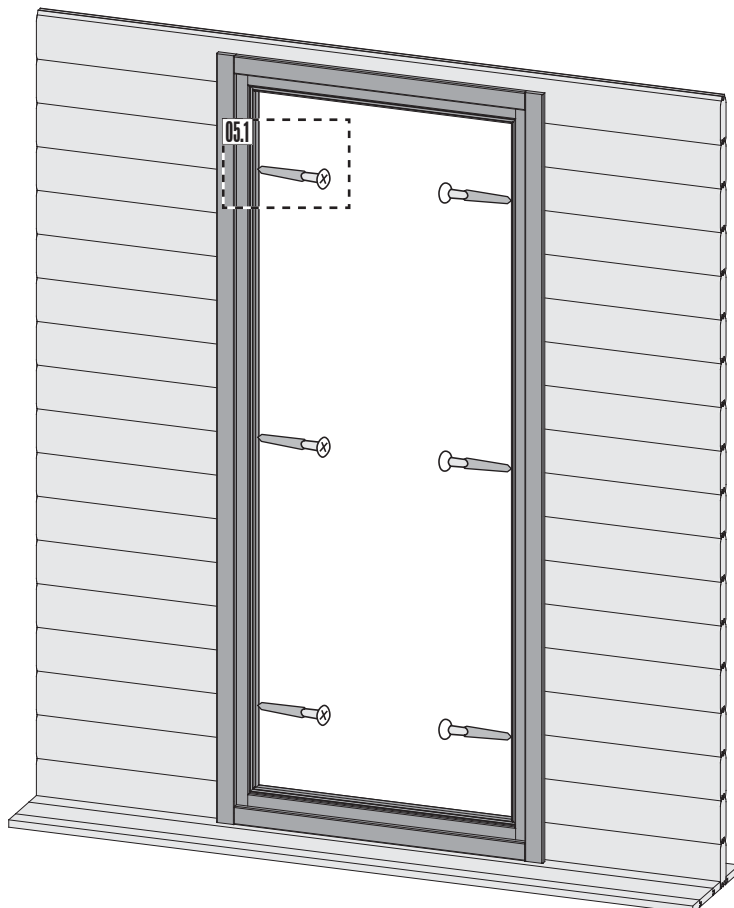

05.1-1

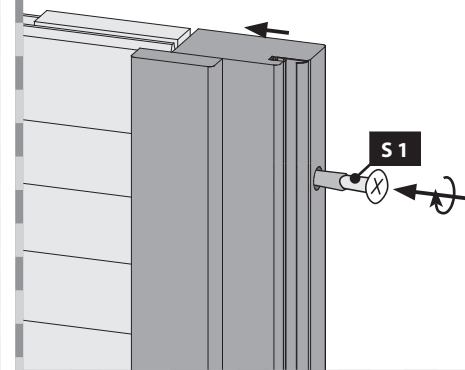

05.1-2

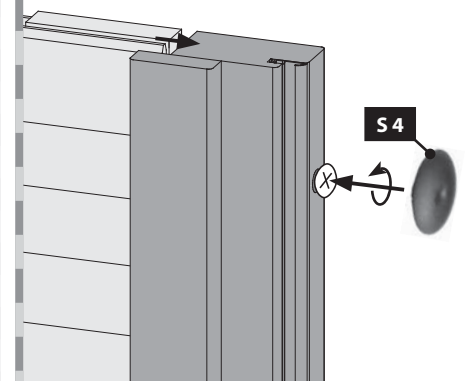

 Einbau Saunatür

 Sauna deur installatie

 Sauna Instalace dveře

 Installation de porte Sauna

 Instalación de la puerta Sauna

 Sauna door installation

 Installazione porta Sauna

06

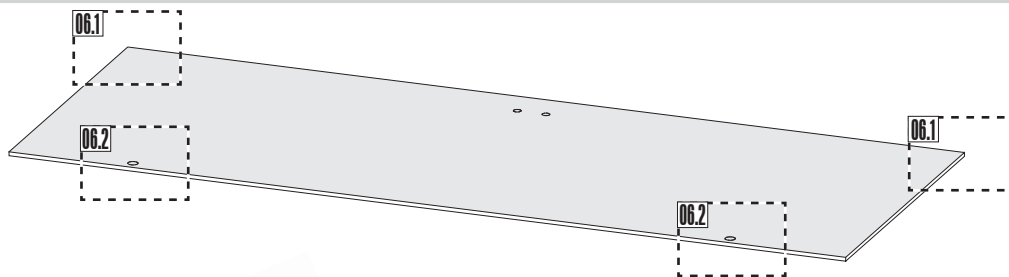

06.1-1

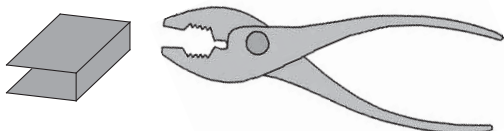

06.1-2

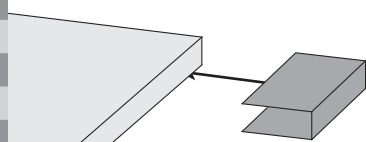

06.1-3

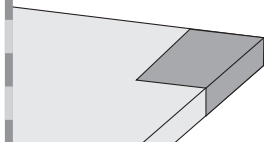

06.2-1

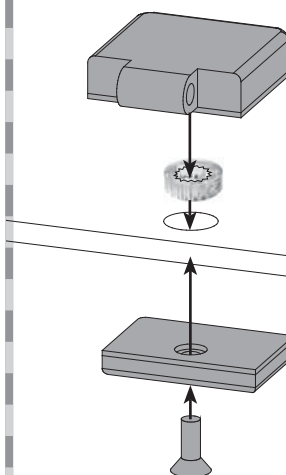

06.2-2

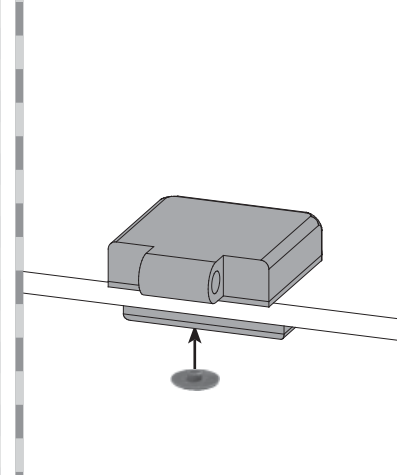

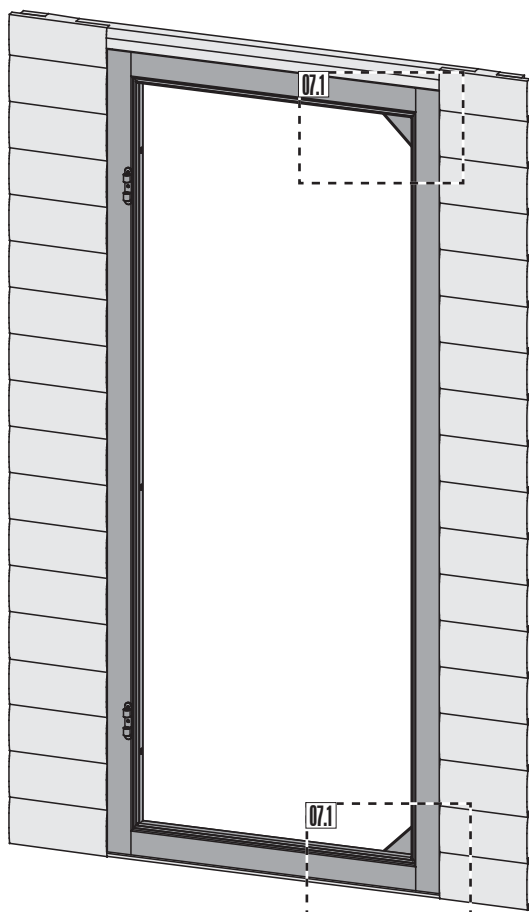

07





 Achtung: Alle Verstell-Excenter müssen in der Glasscheibe die gleiche Grundstellung haben!

 Attention: Tous les excenteurs de positionnement doivent avoir la même position de base dans la vitre!

 Attention: All adjustable eccentrics must have the same basic adjustment in the glass panel!

 Figyelmeztetés: az állítható excentrikusok ugyanabban a helyzetben kell lenniük a üveglapon!

 Atención: Todos los excéntricos regulables tienen que tener la misma posición base en la hoja de cristal.

 Attenzione: Tutti gli eccentrici di regolazione devono avere la stessa posizione base nella lastra di vetro!

 Poznámka: Všechny nastavovací podivínů musí mít stejný základní polohy ve skle!

07.1-1



07.1-2



 Einbau Saunatür

 Sauna deur installatie

 Sauna Instalace dveře

 Installation de porte Sauna

 Instalación de la puerta Sauna

 Sauna door installation

 Installazione porta Sauna

08

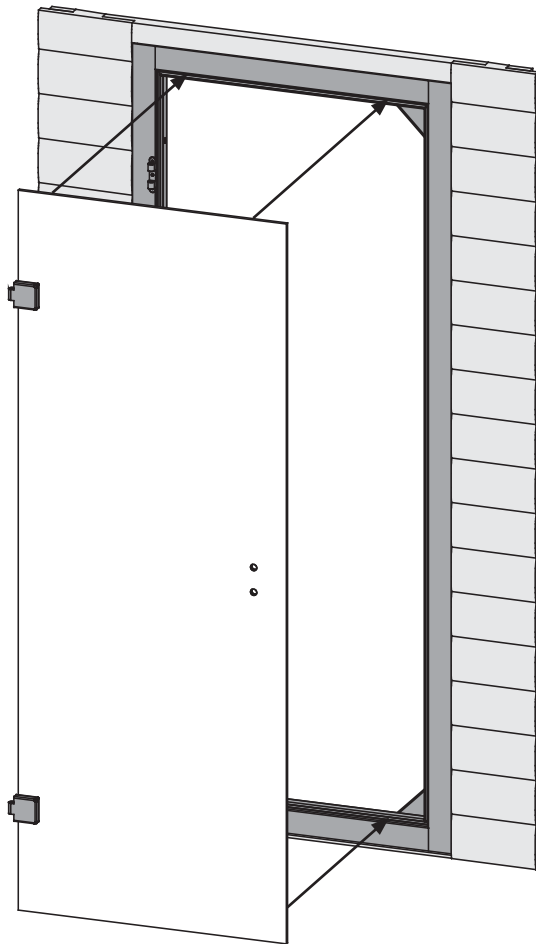

09

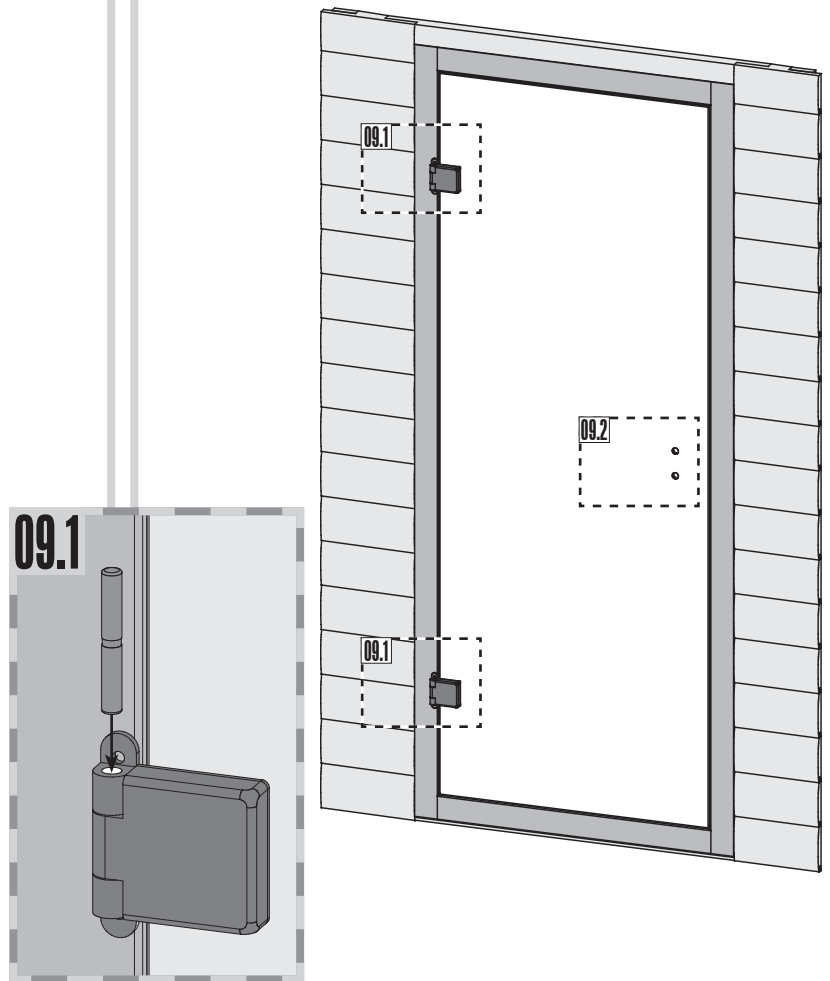

09.2-1

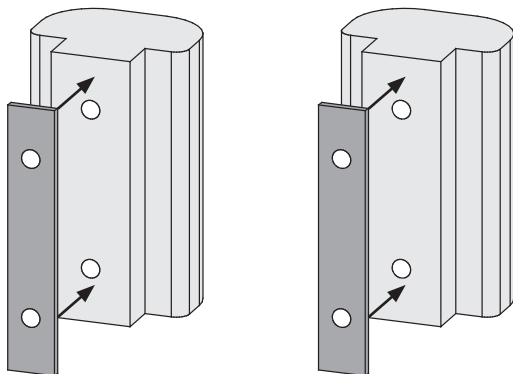

09.2-2

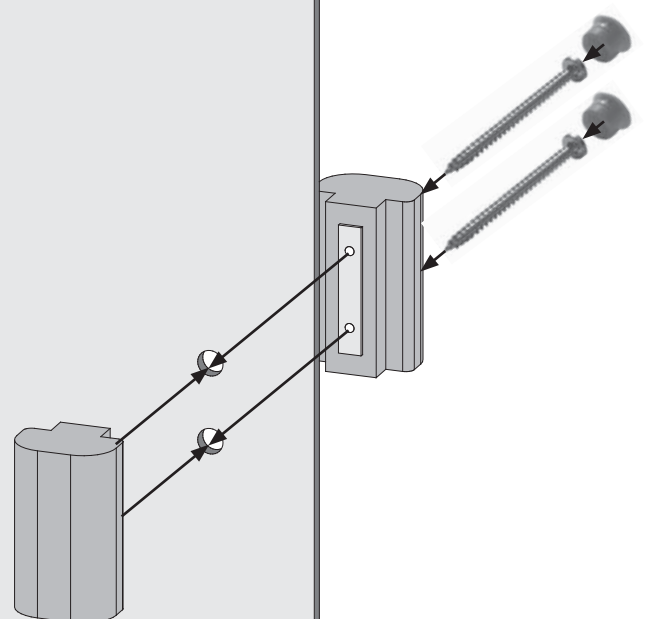

 Einbau Saunatür

 Sauna deur installatie

 Sauna Instalace dveře

 Installation de porte Sauna

 Instalación de la puerta Sauna

 Sauna door installation

 Installazione porta Sauna

10

 **Seitenverstellung + Höhenverstellung**

Achtung: Alle Verstell-Excenter müssen in der Glasscheibe die gleiche Grundstellung haben!

 **Positionnement latéral + positionnement hauteur**

Attention: Tous les excentres de positionnement doivent avoir la même position de base dans la vitre!

 **Lateral adjustment + height adjustment**

Attention: All adjustable eccentrics must have the same basic adjustment in the glass panel!

 **Zijverstelling + hoogteverstelling**

Attentie: alle excentrische verstelelementen moeten in dezelfde stand in de glasplaat worden geplaatst!

 **Regulación lateral + regulación de la altura**

Atención: Todos los excéntricos regulables tienen que tener la misma posición base en la hoja de cristal.

 **Regolazione laterale + regolazione dell'altezza**

Attenzione: Tutti gli eccentrici di regolazione devono avere la stessa posizione base nella lastra di vetro!

 **Boční nastavení + nastavení výšky**

Poznámka: Všechny nastavovací podivínů musí mít stejný základní polohy ve skle!

